

427 Murphy Street

SUBMITTED BY

Ray White Rockhampton Casey
stockers@cqoz.com

CREATED ON

2021-11-23

Floors

2

▼ Ground Floor



▼ **Carpport**
Ground Floor

WIDTH: 5.95 m • LENGTH: 5.45 m
AREA: 32.44 m² • PERIMETER: 22.80 m

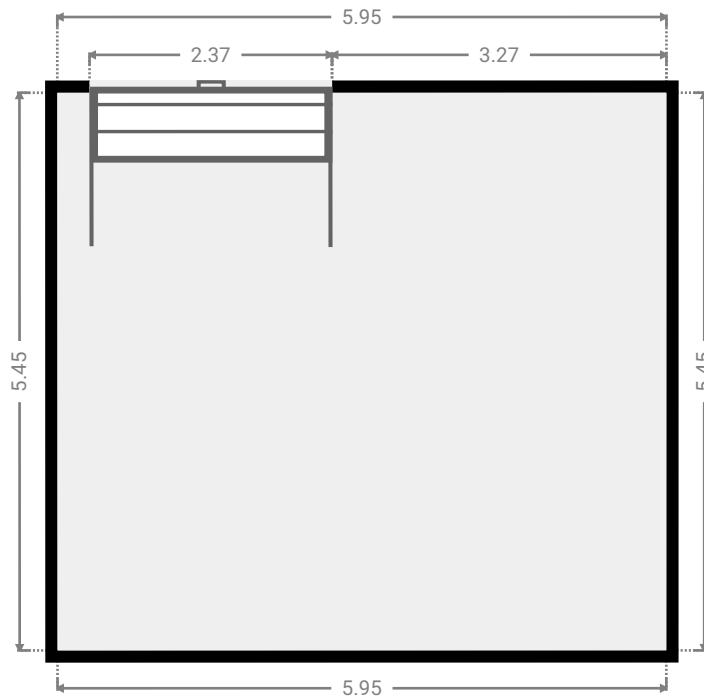
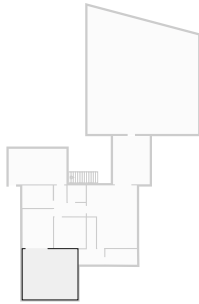

▼ **Garage**
Ground Floor

WIDTH: 3.32 m • LENGTH: 4.27 m
AREA: 14.18 m² • PERIMETER: 15.18 m

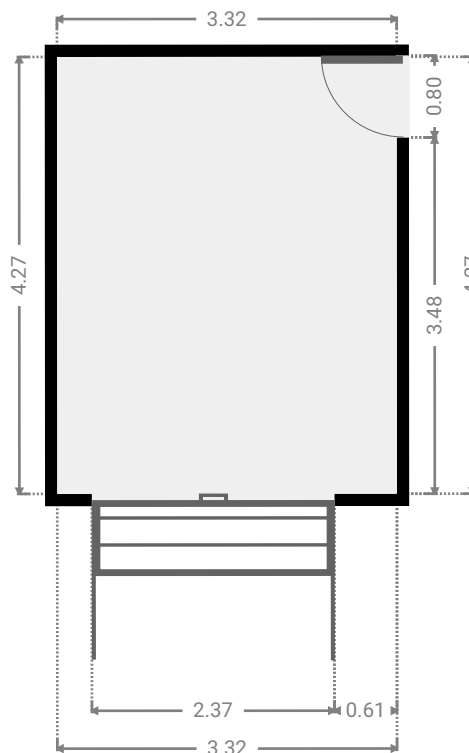
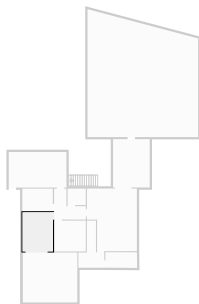

▼ **Hall**
Ground Floor

WIDTH: 3.46 m • LENGTH: 3.38 m
AREA: 7.62 m² • PERIMETER: 13.66 m

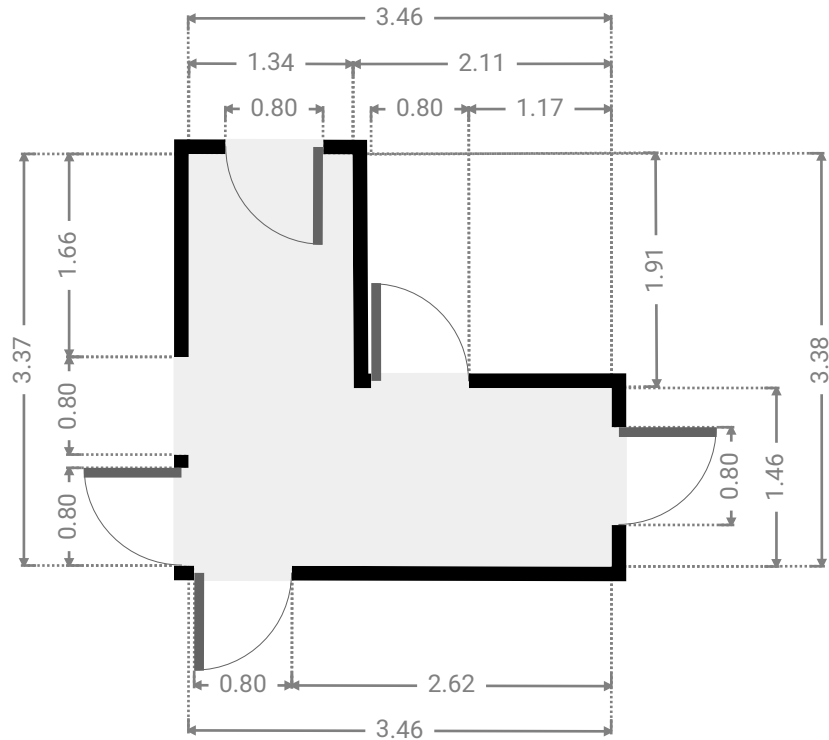
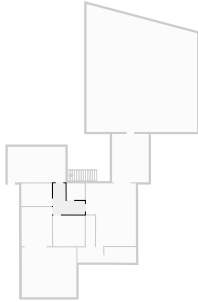

▼ **Bedroom**
Ground Floor

WIDTH: 3.46 m • LENGTH: 3.36 m
AREA: 11.61 m² • PERIMETER: 13.63 m

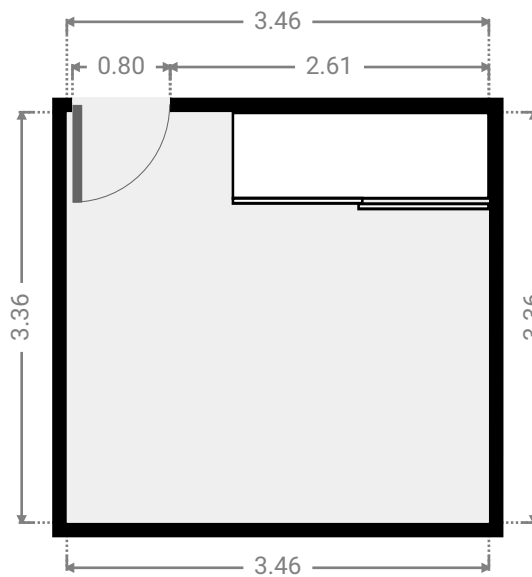
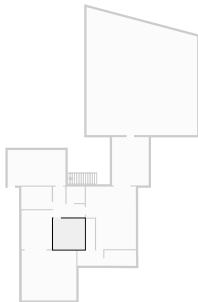

▼ **Kitchen**
Ground Floor

WIDTH: 3.32 m • LENGTH: 2.46 m
AREA: 8.17 m² • PERIMETER: 11.56 m

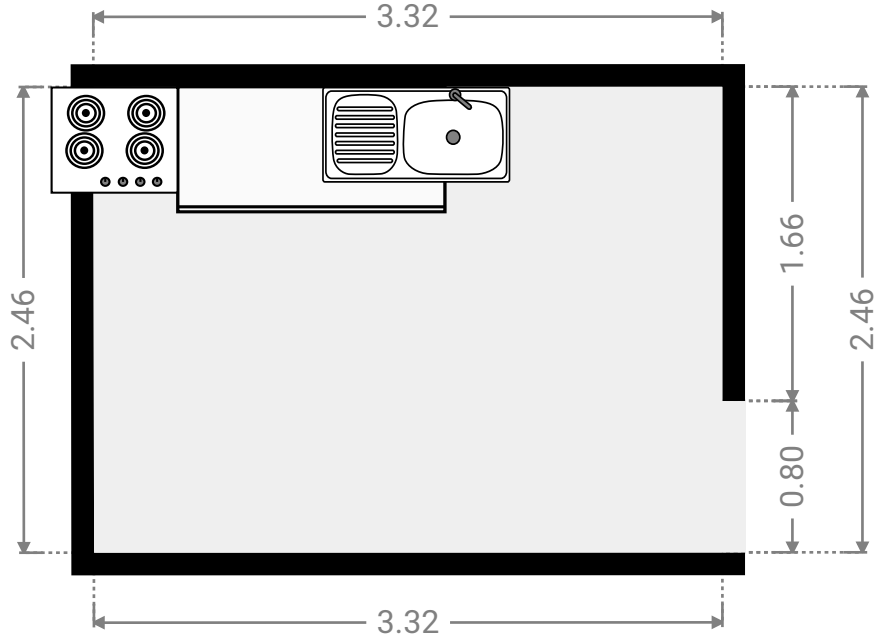
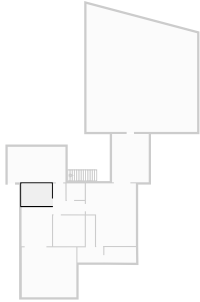

▼ **Bathroom**
Ground Floor

WIDTH: 1.98 m • LENGTH: 1.80 m
AREA: 3.56 m² • PERIMETER: 7.56 m

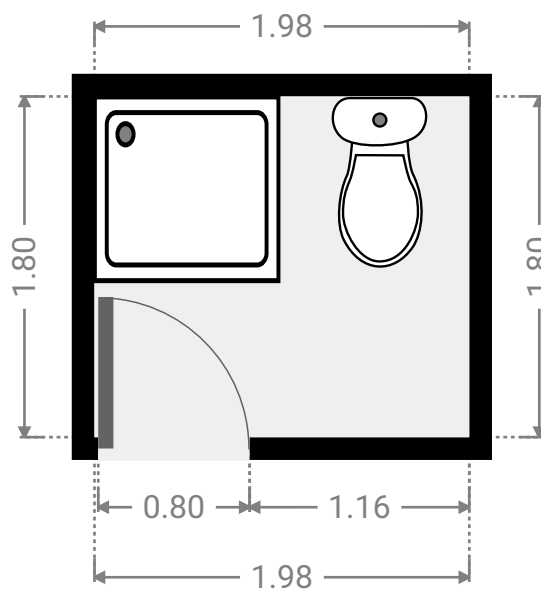
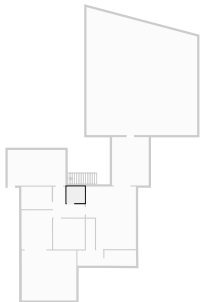

▼ **Living Room**
Ground Floor

WIDTH: 5.46 m • LENGTH: 6.84 m
AREA: 33.46 m² • PERIMETER: 24.58 m

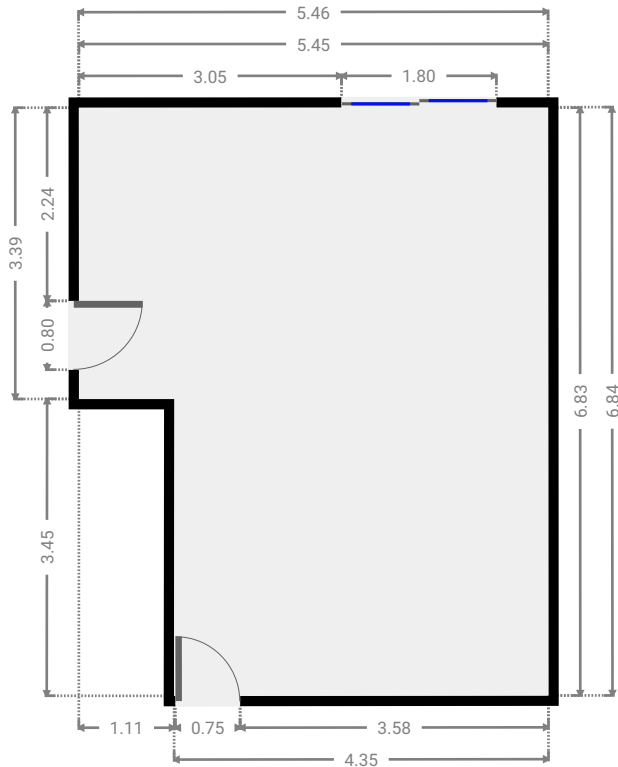
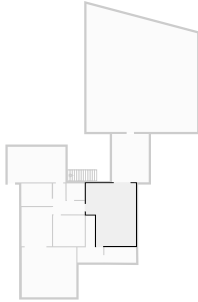

▼ **Hallway**
Ground Floor

WIDTH: 2.82 m • LENGTH: 5.13 m
AREA: 8.14 m² • PERIMETER: 15.90 m

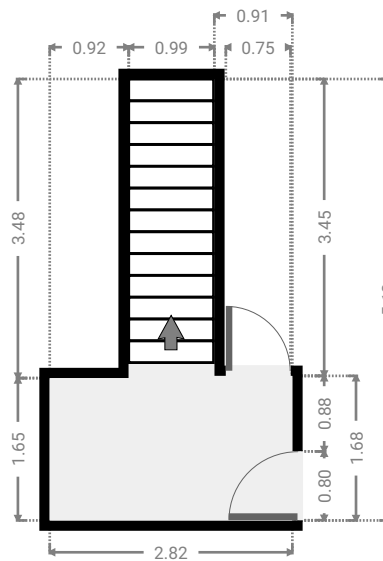
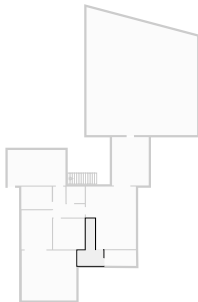

▼ Other
Ground Floor

WIDTH: 6.30 m • LENGTH: 3.88 m
AREA: 24.45 m² • PERIMETER: 20.36 m

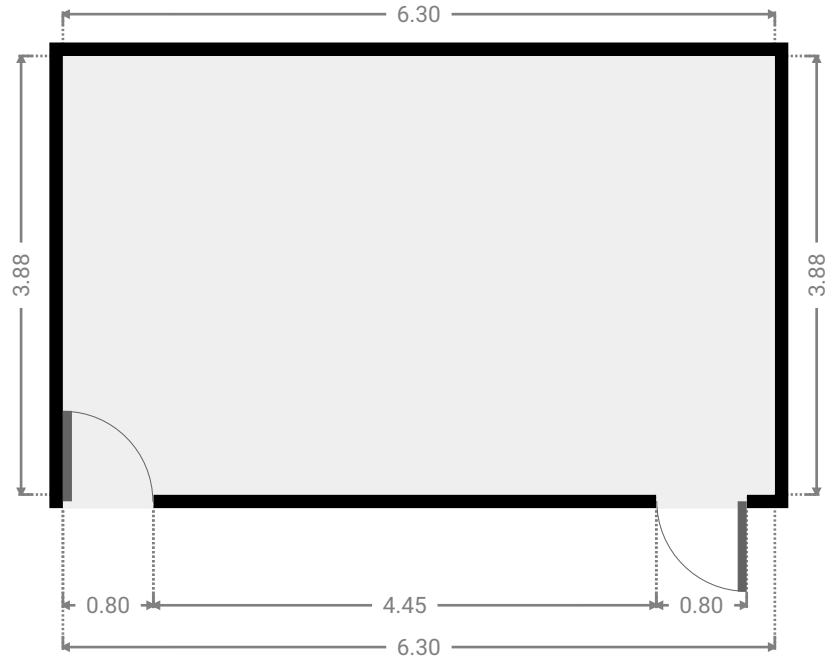
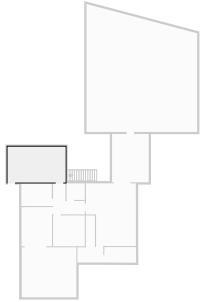

▼ Other
Ground Floor

WIDTH: 4.00 m • LENGTH: 5.27 m
AREA: 21.08 m² • PERIMETER: 18.54 m

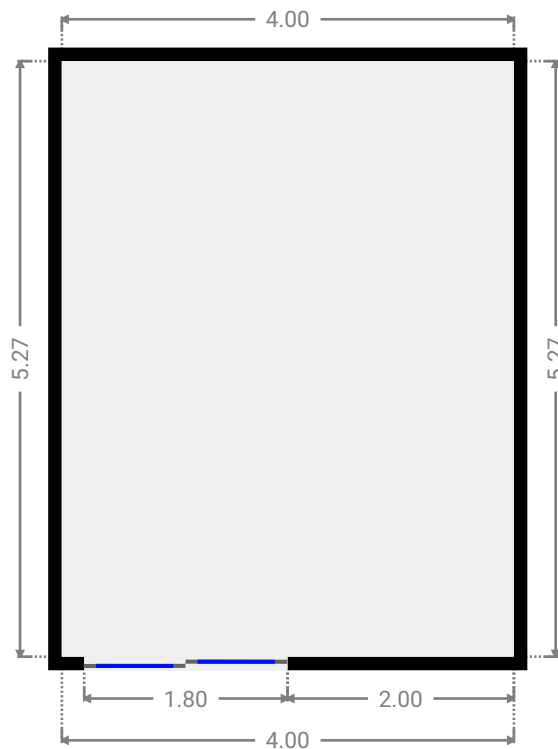
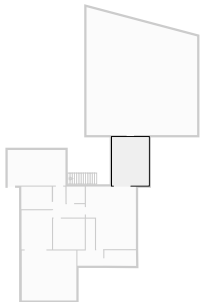

▼ **Bedroom**
Ground Floor

WIDTH: 12.07 m • LENGTH: 13.96 m
AREA: 149.23 m² • PERIMETER: 49.28 m

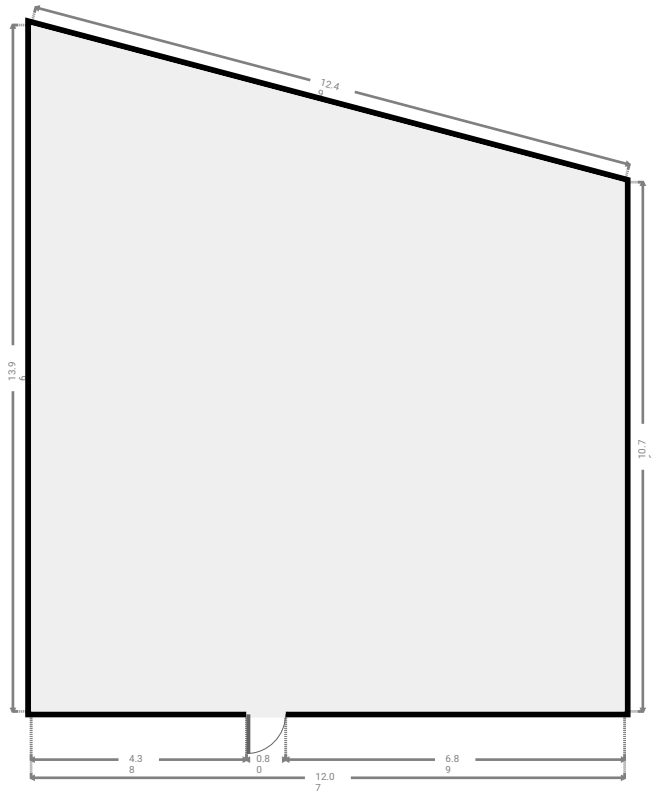
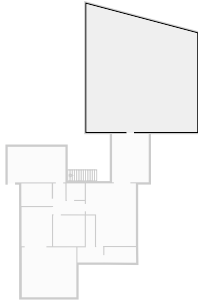

▼ **Other**
Ground Floor

WIDTH: 3.48 m • LENGTH: 1.70 m
AREA: 5.85 m² • PERIMETER: 10.30 m

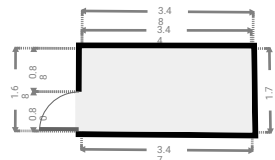
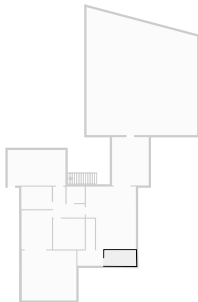

▼ 1st Floor

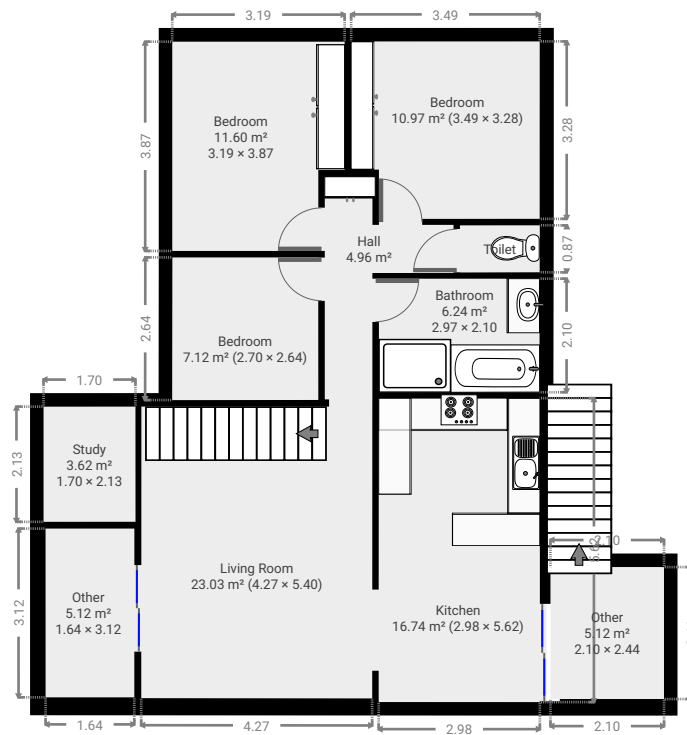

▼ **Living Room**
1st Floor

WIDTH: 5.40 m • LENGTH: 4.27 m
AREA: 23.03 m² • PERIMETER: 19.33 m

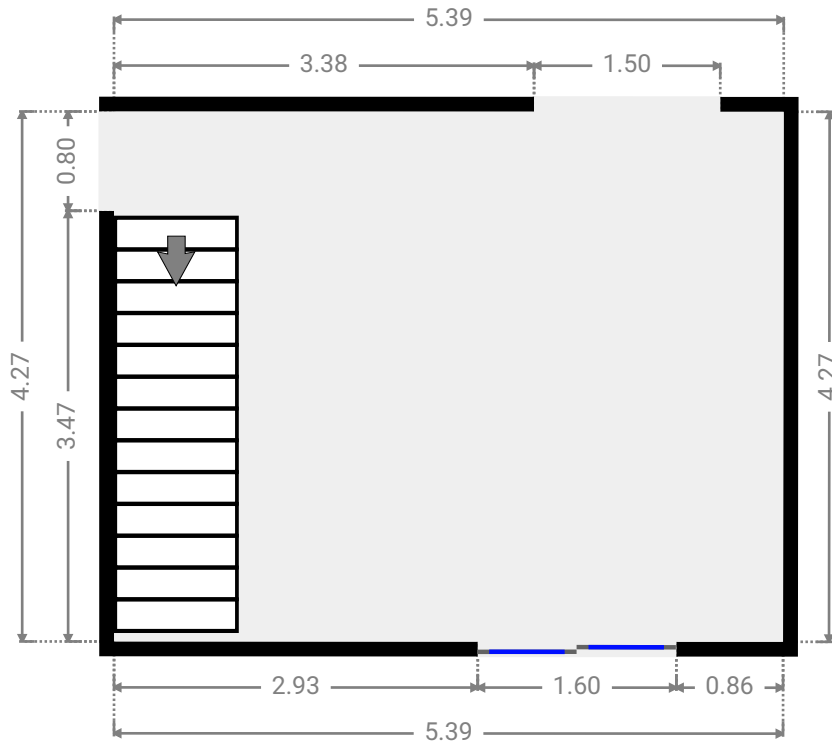
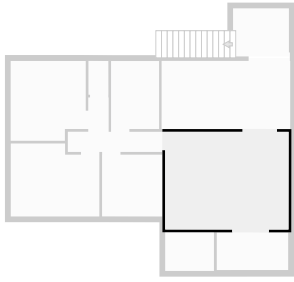

▼ **Other**
1st Floor

WIDTH: 3.12 m • LENGTH: 1.64 m
AREA: 5.12 m² • PERIMETER: 9.52 m

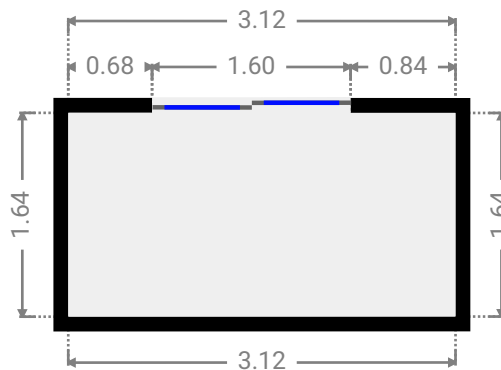
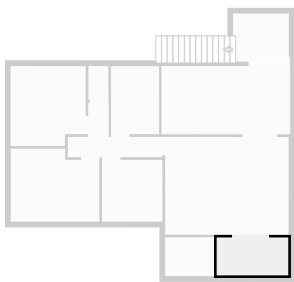

▼ **Study**
1st Floor

WIDTH: 2.13 m • LENGTH: 1.70 m
AREA: 3.62 m² • PERIMETER: 7.66 m

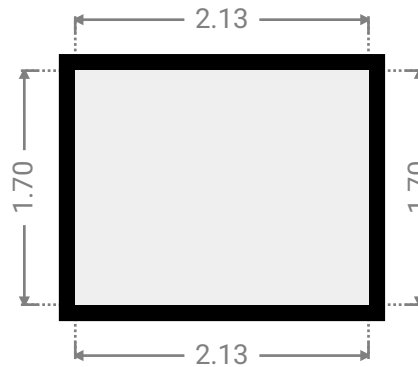
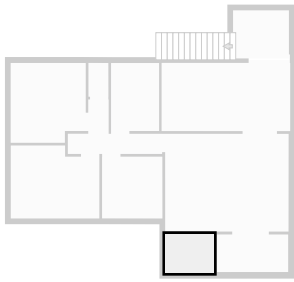

▼ **Kitchen**
1st Floor

WIDTH: 5.62 m • LENGTH: 2.98 m
AREA: 16.74 m² • PERIMETER: 17.20 m

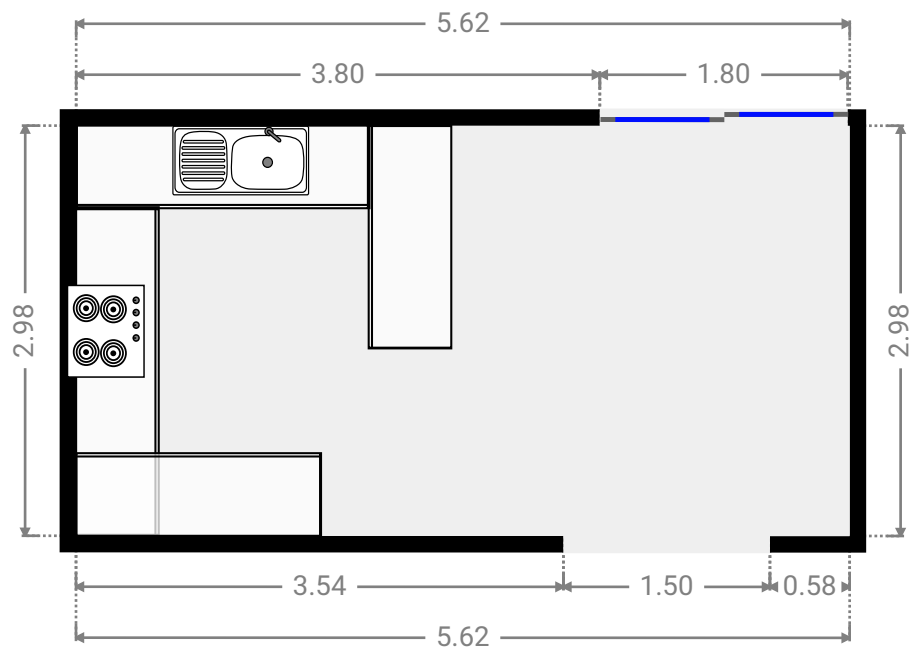
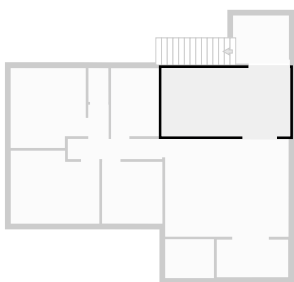

▼ **Other**
1st Floor

WIDTH: 2.44 m • LENGTH: 2.10 m
AREA: 5.12 m² • PERIMETER: 9.08 m

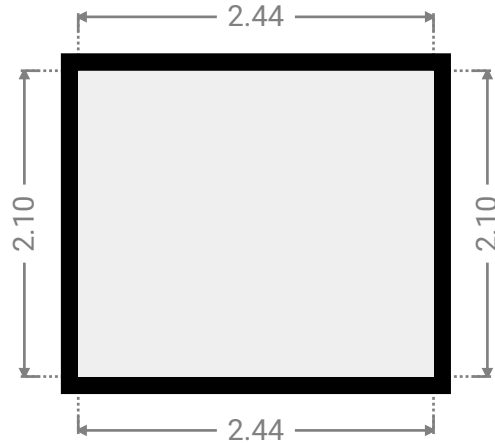
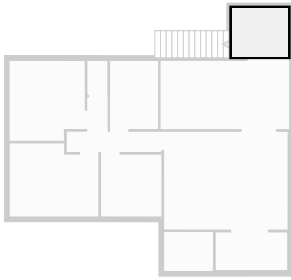

▼ **Hall**
1st Floor

WIDTH: 4.12 m • LENGTH: 2.38 m
AREA: 4.96 m² • PERIMETER: 13.00 m

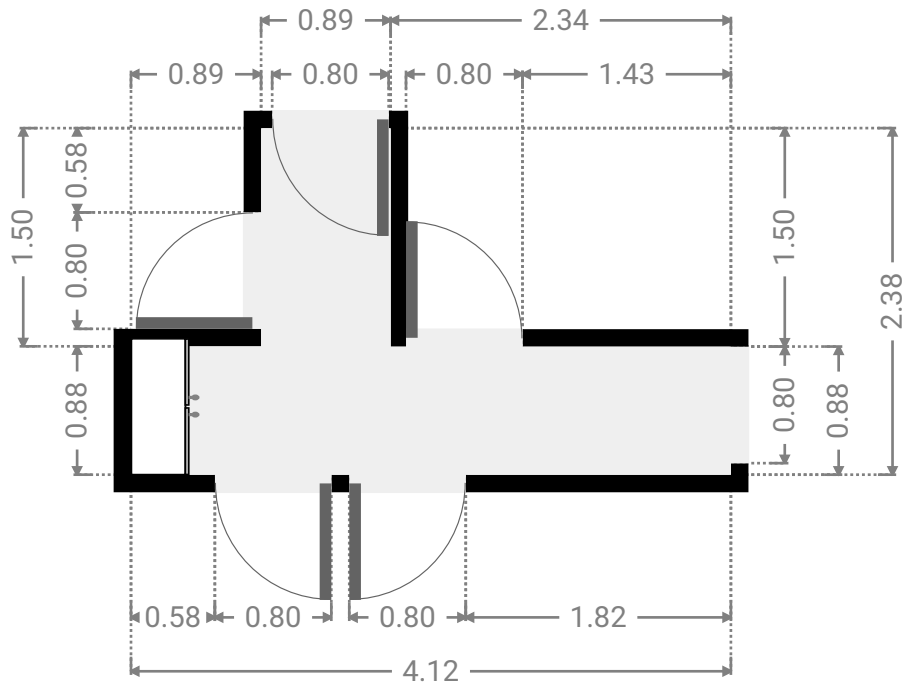
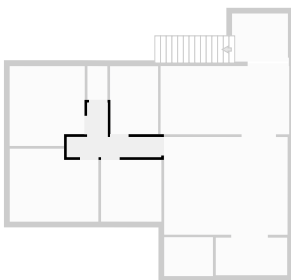

▼ **Bathroom**
1st Floor

WIDTH: 2.10 m • LENGTH: 2.97 m
AREA: 6.24 m² • PERIMETER: 10.14 m

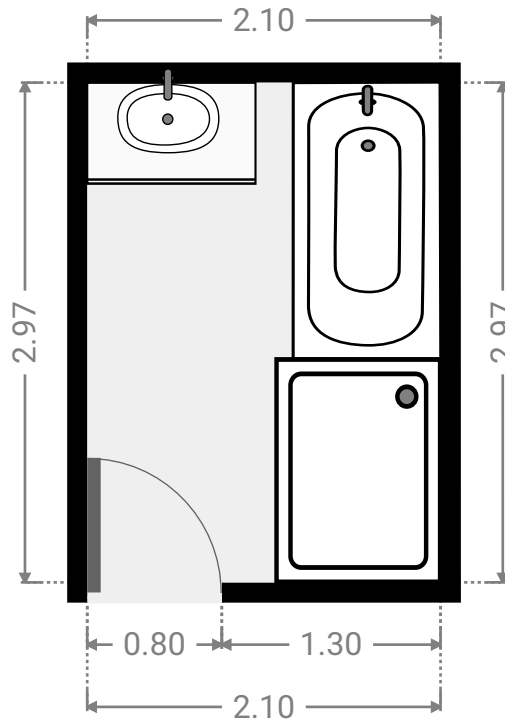
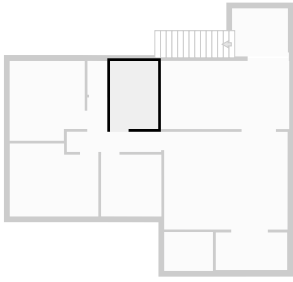

▼ **Toilet**
1st Floor

WIDTH: 0.87 m • LENGTH: 1.48 m
AREA: 1.28 m² • PERIMETER: 4.69 m

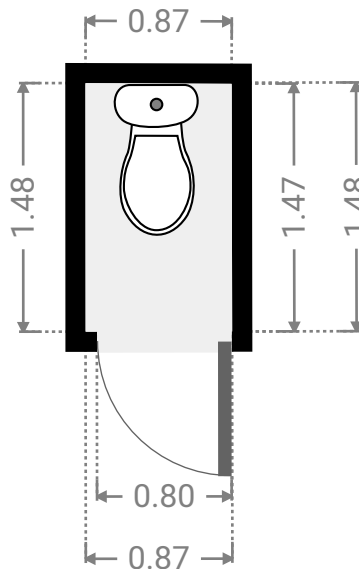
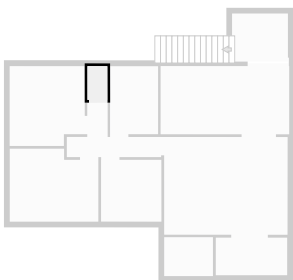

▼ **Bedroom**
1st Floor

WIDTH: 3.28 m • LENGTH: 3.49 m
AREA: 10.97 m² • PERIMETER: 13.53 m

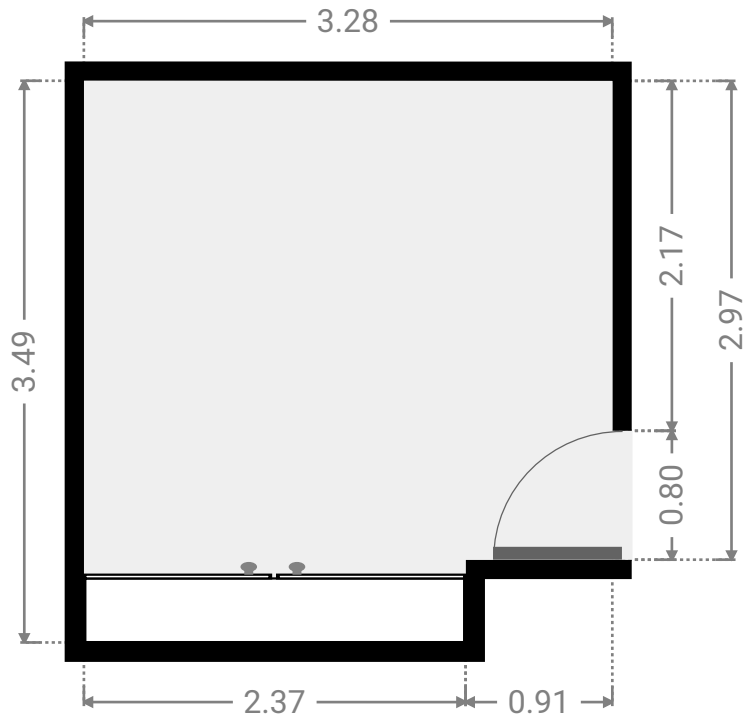
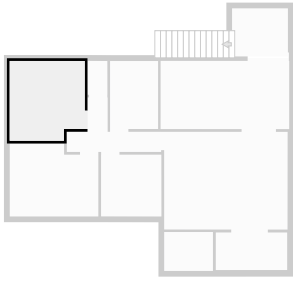

▼ **Bedroom**
1st Floor

WIDTH: 3.87 m • LENGTH: 3.19 m
AREA: 11.60 m² • PERIMETER: 14.11 m

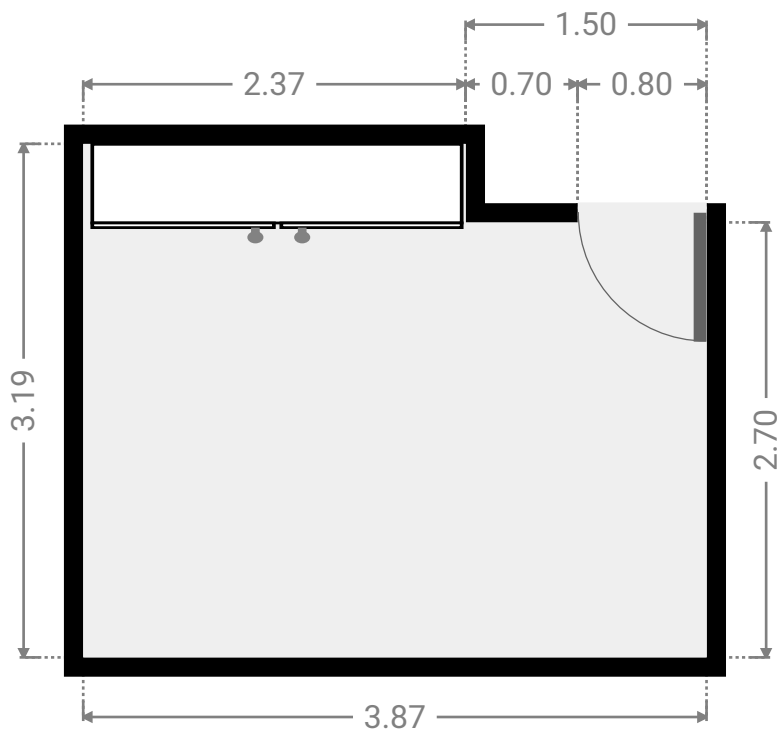
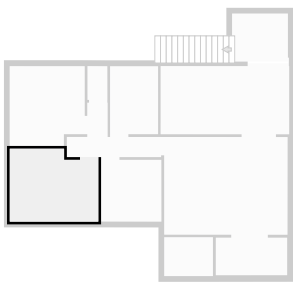

▼ **Bedroom**
1st Floor

WIDTH: 2.64 m • LENGTH: 2.70 m
AREA: 7.12 m² • PERIMETER: 10.67 m

