

418 Stenhouse Street

SUBMITTED BY
Janelle Casey

CREATED ON
2021-10-26

Floors
2

▼ Basement

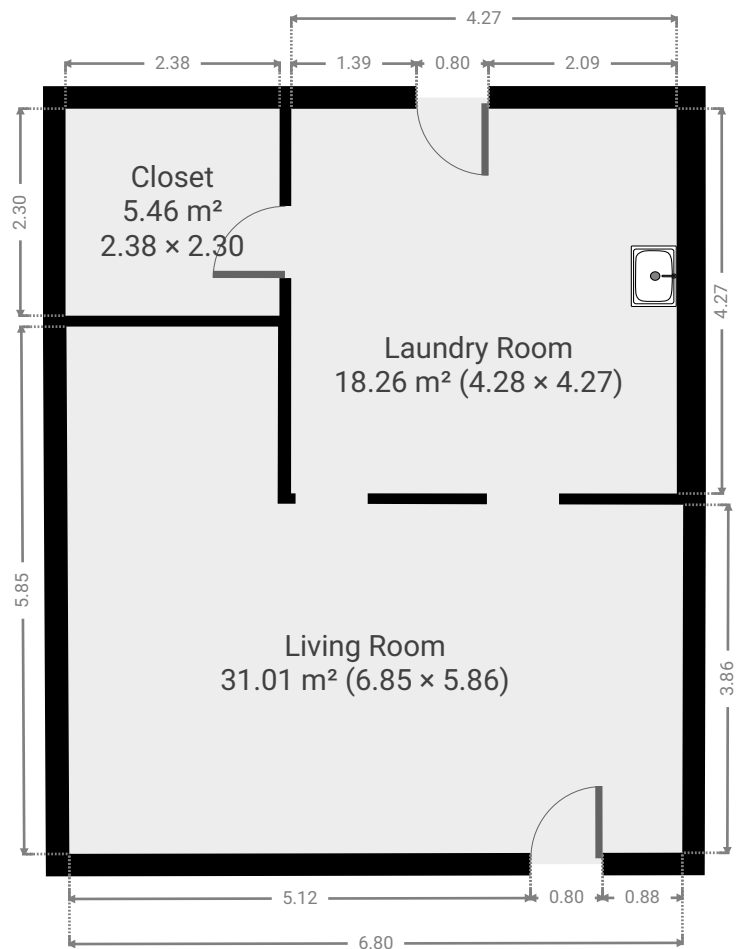
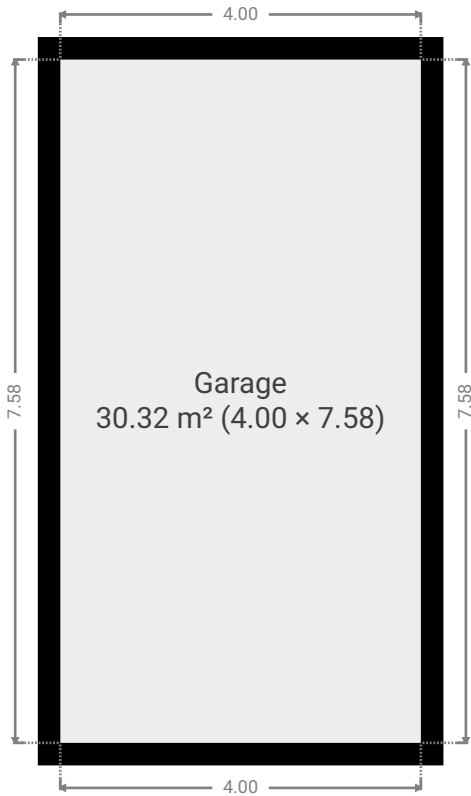

▼ **Living Room**
Basement

WIDTH: 6.85 m • LENGTH: 5.86 m
AREA: 31.01 m² • PERIMETER: 25.33 m

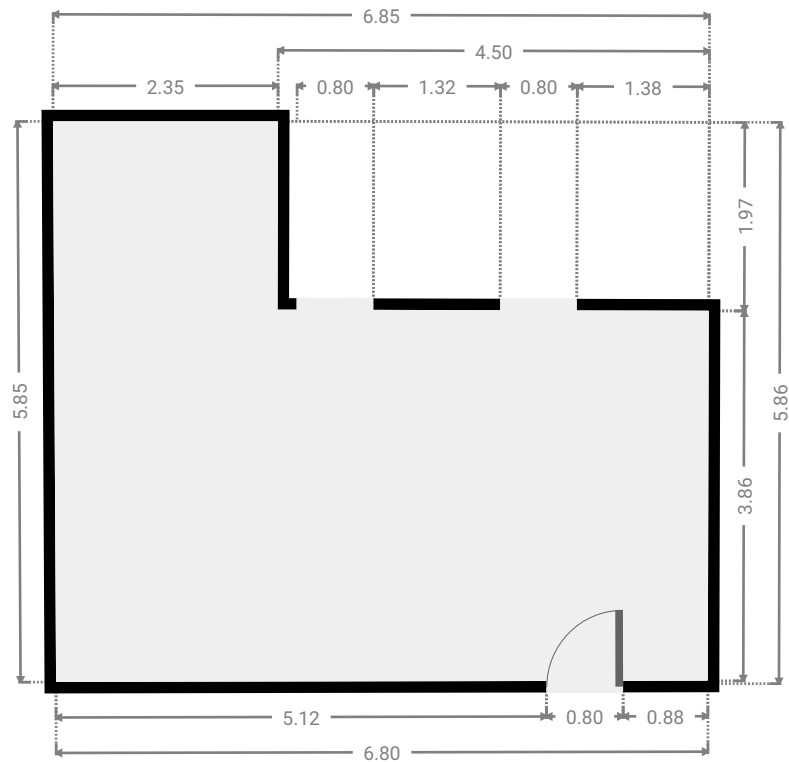
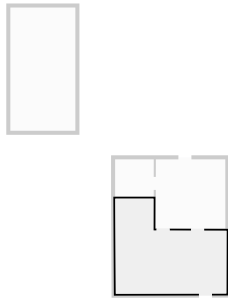

▼ **Laundry Room**
Basement

WIDTH: 4.28 m • LENGTH: 4.27 m
AREA: 18.26 m² • PERIMETER: 17.09 m

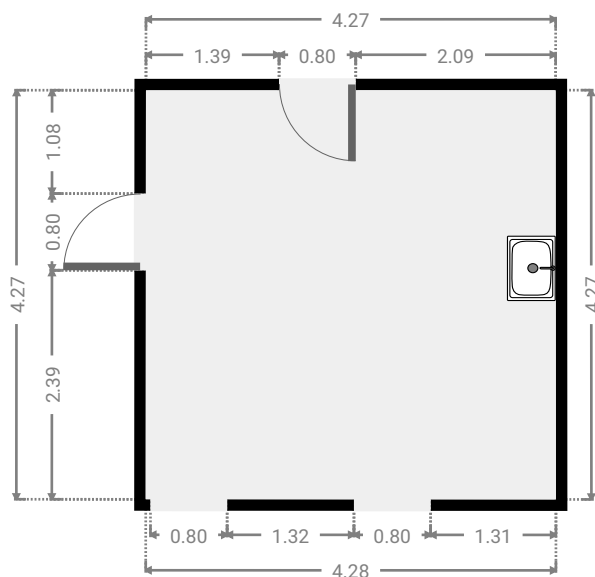
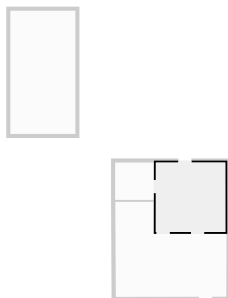

▼ Closet
Basement

WIDTH: 2.38 m • LENGTH: 2.30 m
AREA: 5.46 m² • PERIMETER: 9.34 m

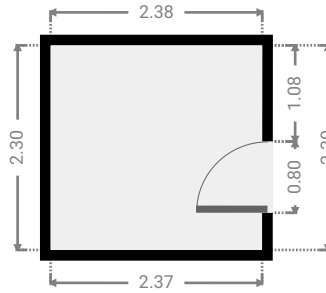
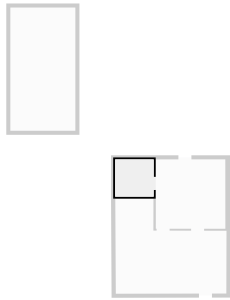

▼ Garage
Basement

WIDTH: 4.00 m • LENGTH: 7.58 m
AREA: 30.32 m² • PERIMETER: 23.16 m

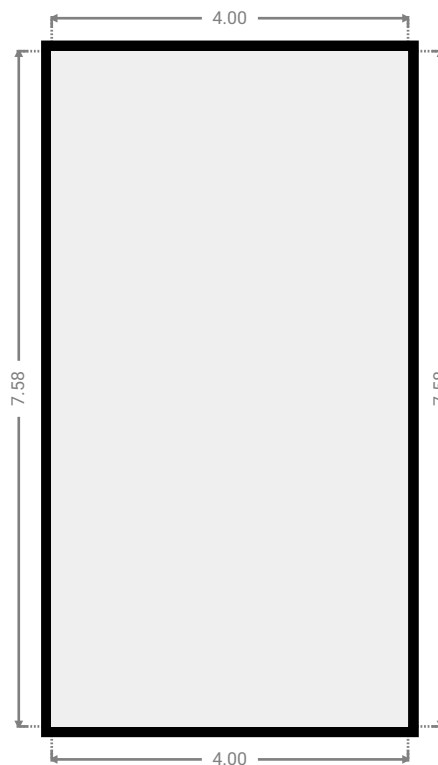
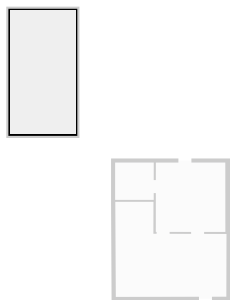

▼ Ground Floor



FLOORS: 2

▼ **Living Room**
Ground Floor

WIDTH: 6.56 m • LENGTH: 5.72 m
AREA: 30.43 m² • PERIMETER: 24.56 m

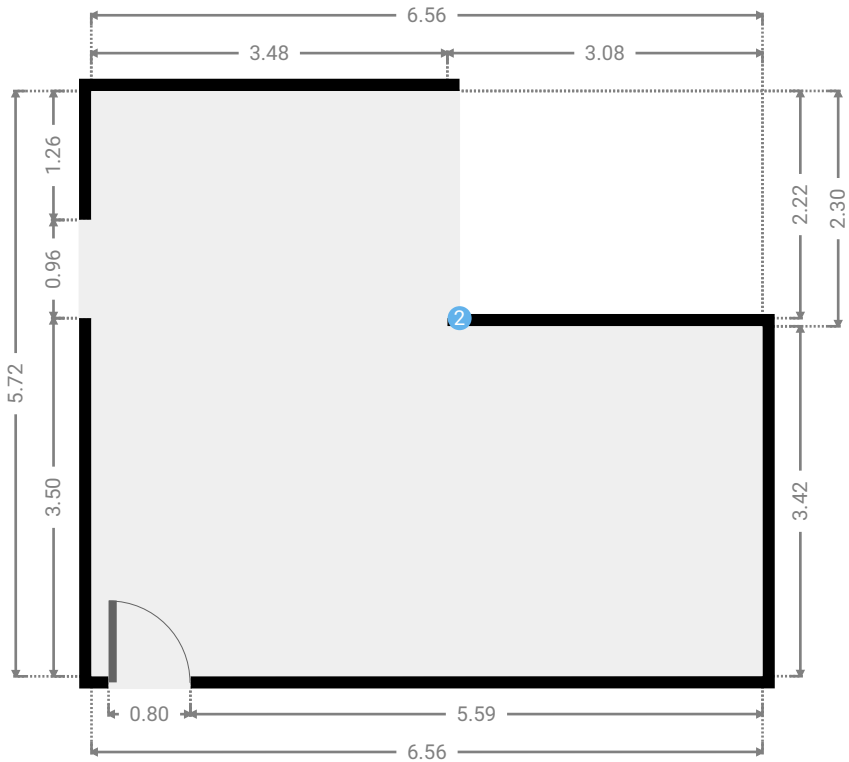
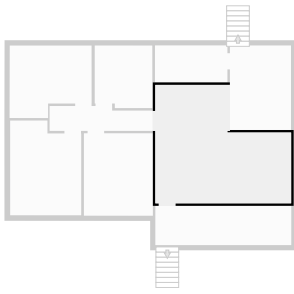

▼ **Kitchen**
Ground Floor

WIDTH: 2.95 m • LENGTH: 4.08 m
AREA: 12.04 m² • PERIMETER: 14.06 m

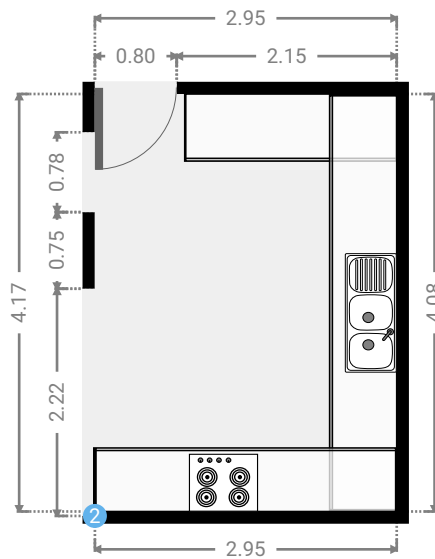
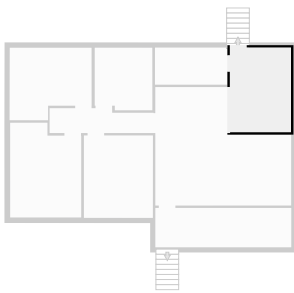

▼ **Kitchen**/Ground Floor

2 **OPENING**

Height
0.00 m



▼ **Closet**
Ground Floor

WIDTH: 3.50 m • LENGTH: 1.79 m
AREA: 6.26 m² • PERIMETER: 10.58 m

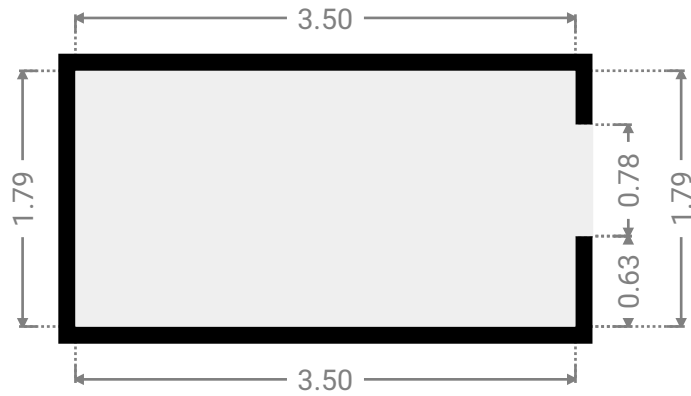
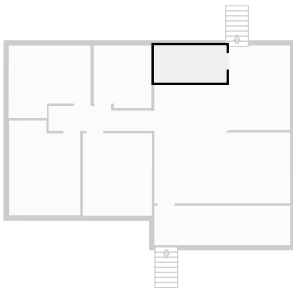

▼ **Hall**
Ground Floor

WIDTH: 5.02 m • LENGTH: 1.20 m
AREA: 5.58 m² • PERIMETER: 12.44 m

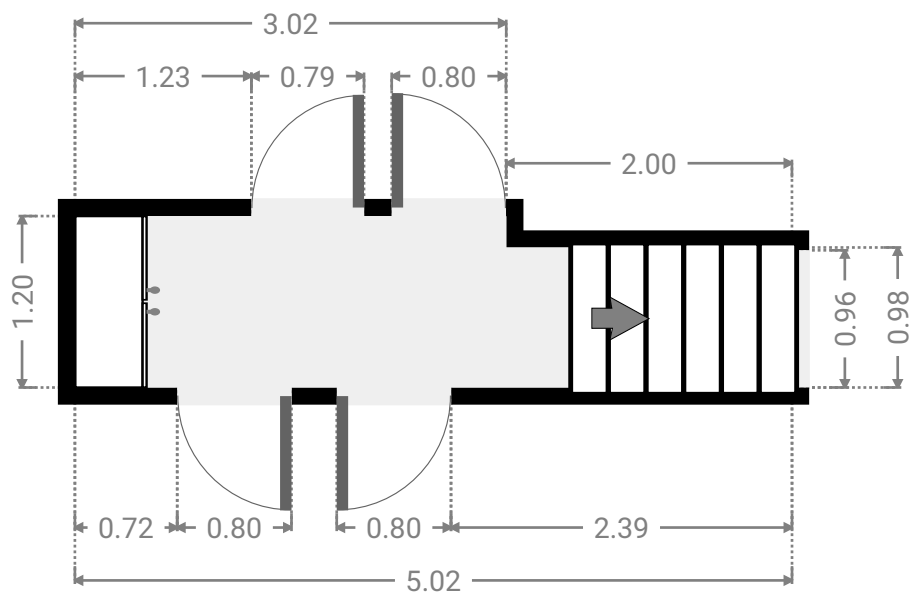
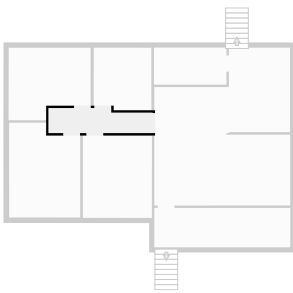

▼ Bathroom
Ground Floor

WIDTH: 2.78 m • LENGTH: 3.03 m
AREA: 8.19 m² • PERIMETER: 11.61 m

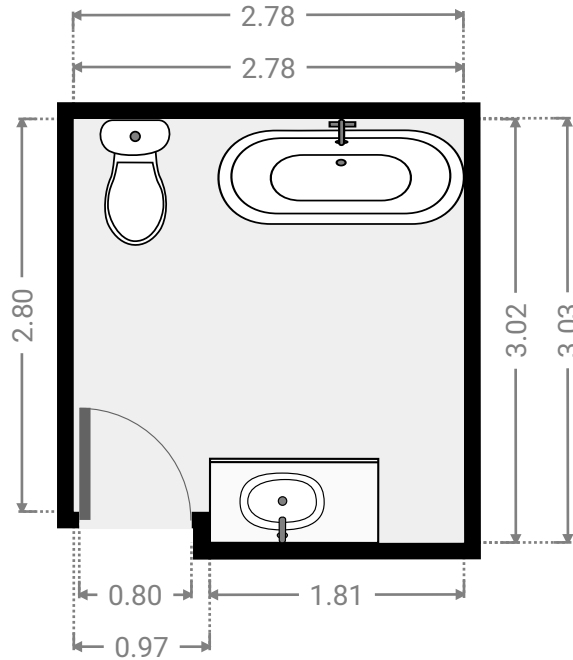
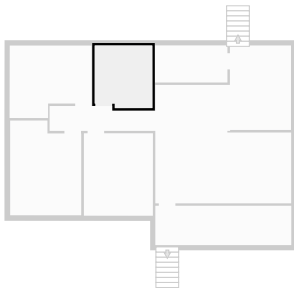

▼ Bedroom
Ground Floor

WIDTH: 3.96 m • LENGTH: 3.50 m
AREA: 12.37 m² • PERIMETER: 14.91 m

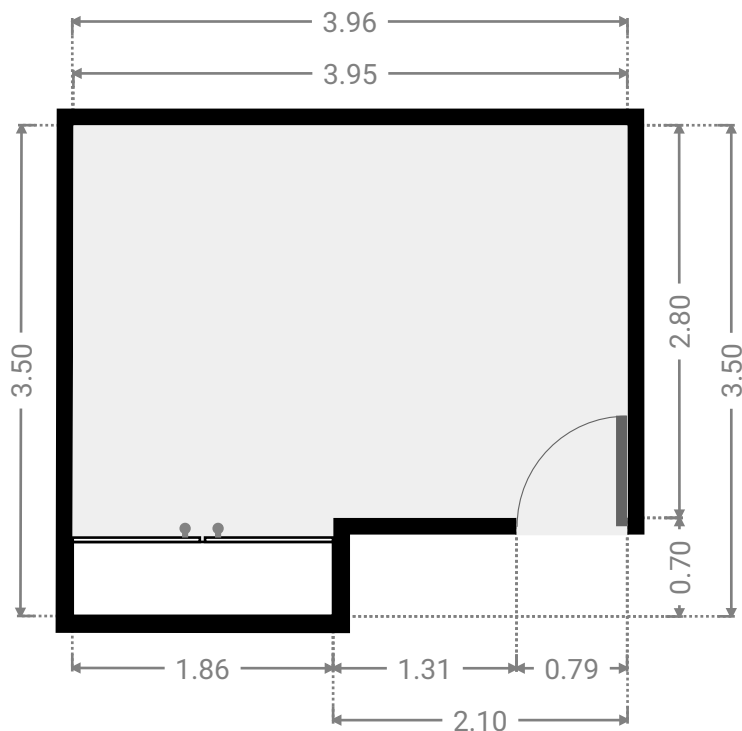
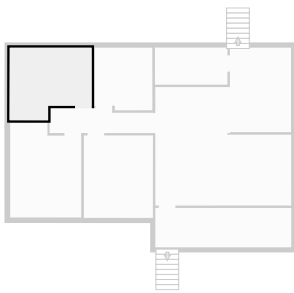

FLOORS: 2

▼ **Bedroom**
Ground Floor

WIDTH: 3.43 m • LENGTH: 4.57 m
AREA: 14.67 m² • PERIMETER: 16.01 m

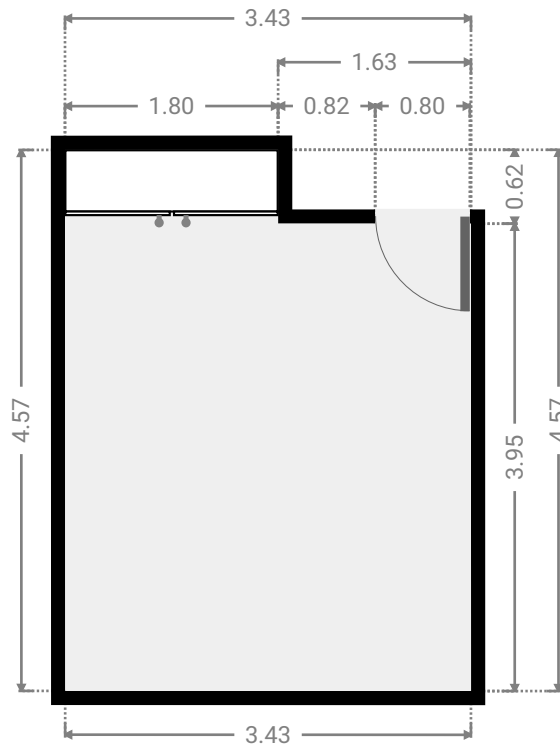
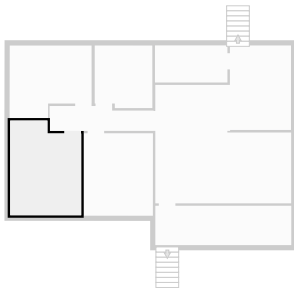

▼ **Bedroom**
Ground Floor

WIDTH: 3.33 m • LENGTH: 3.98 m
AREA: 13.26 m² • PERIMETER: 14.62 m

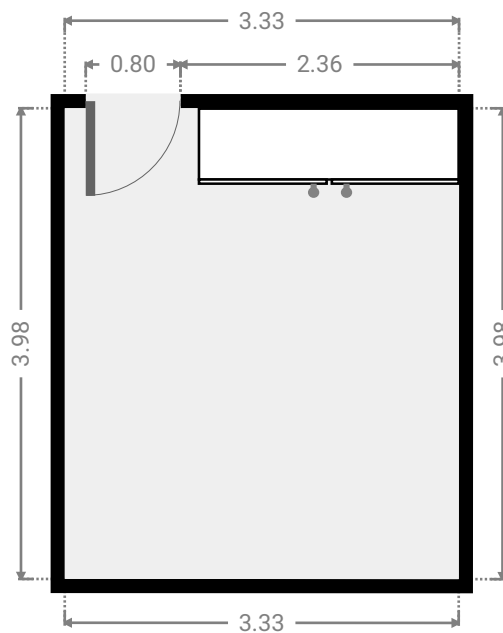
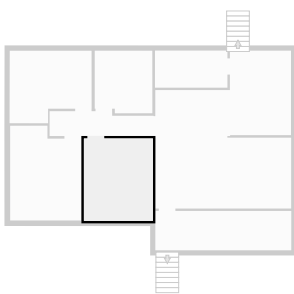

▼ Other
Ground Floor

WIDTH: 6.56 m • LENGTH: 1.90 m
AREA: 12.47 m² • PERIMETER: 16.93 m

