

# 40 Pillich Street

**SUBMITTED BY**

Ray White Rockhampton Casey  
stockers@cqoz.com

---

**CREATED ON**

2021-12-22

---

**Floors**

1

---

▼ Ground Floor



▼ **Bathroom**  
Ground Floor

WIDTH: 2.60 m • LENGTH: 2.36 m  
AREA: 6.14 m<sup>2</sup> • PERIMETER: 9.92 m

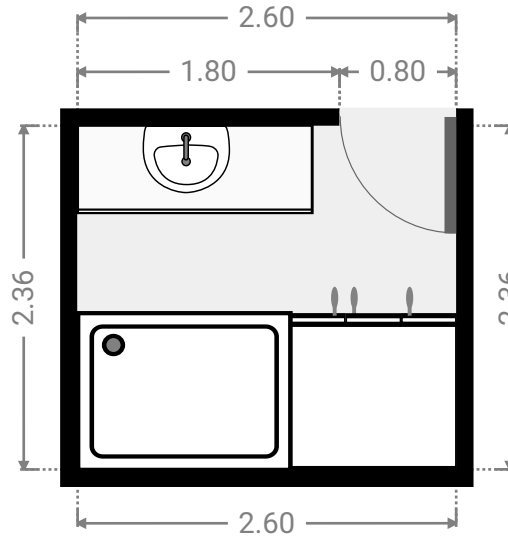
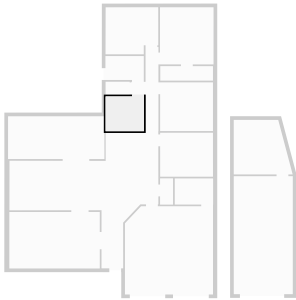

▼ **Awning**  
Ground Floor

WIDTH: 3.99 m • LENGTH: 3.70 m  
AREA: 12.94 m<sup>2</sup> • PERIMETER: 14.52 m

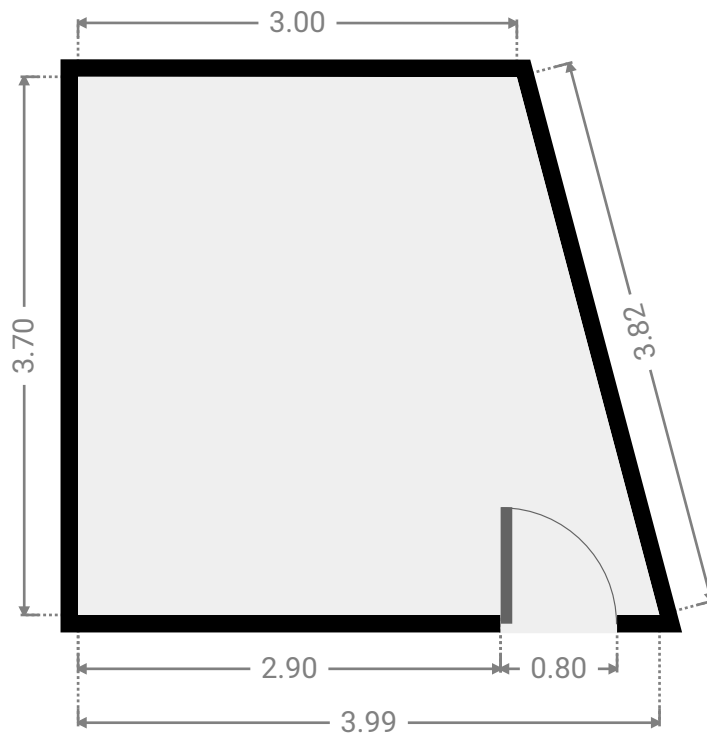
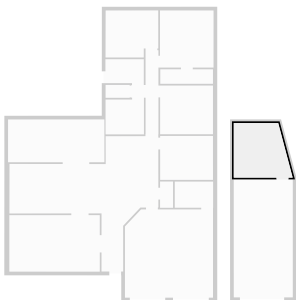

▼ **Shed**  
Ground Floor

WIDTH: 4.00 m • LENGTH: 8.00 m  
AREA: 32.01 m<sup>2</sup> • PERIMETER: 24.00 m

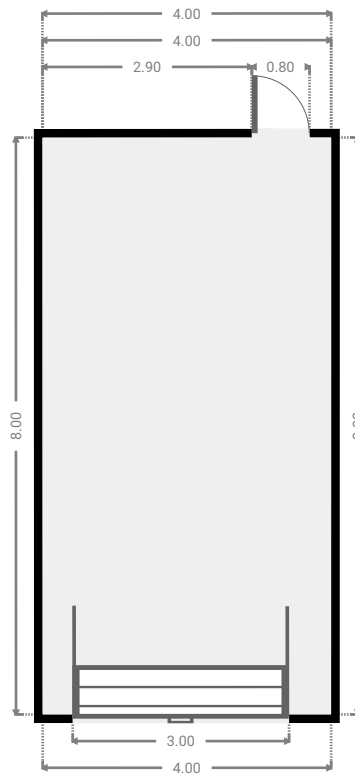
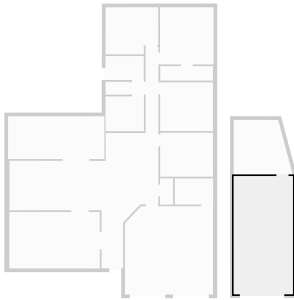

▼ **Patio**  
Ground Floor

WIDTH: 6.53 m • LENGTH: 2.90 m  
AREA: 18.93 m<sup>2</sup> • PERIMETER: 18.86 m

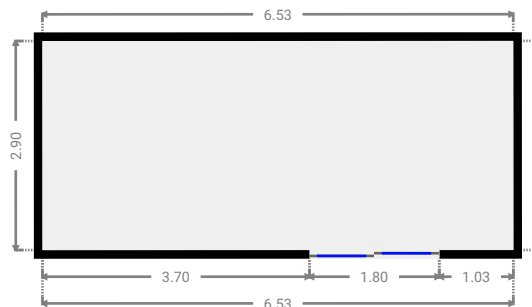
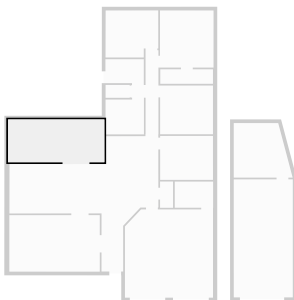

▼ **Bedroom**  
Ground Floor

WIDTH: 3.57 m • LENGTH: 3.19 m  
AREA: 10.78 m<sup>2</sup> • PERIMETER: 13.52 m

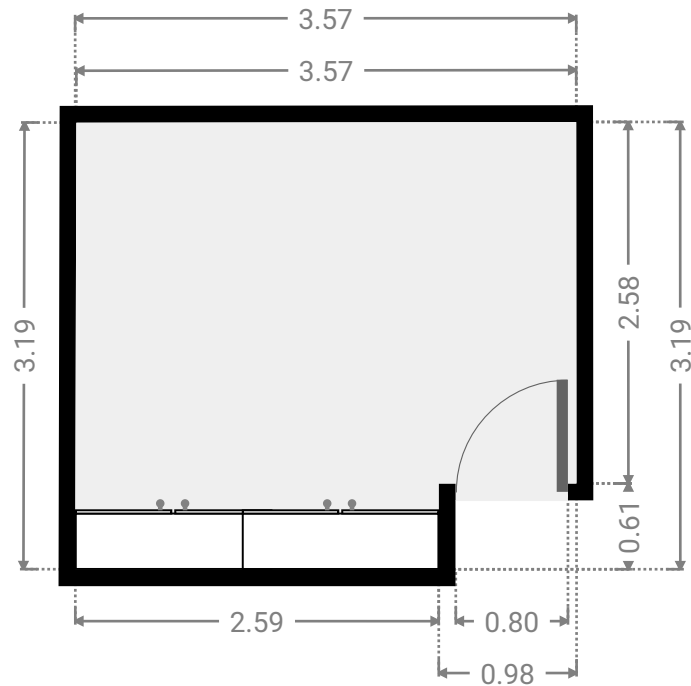
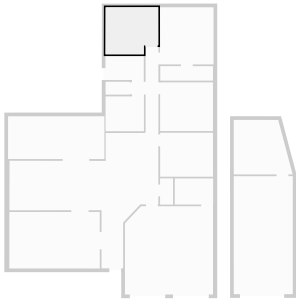

▼ **Master Bedroom**  
Ground Floor

WIDTH: 3.63 m • LENGTH: 3.87 m  
AREA: 14.05 m<sup>2</sup> • PERIMETER: 15.00 m

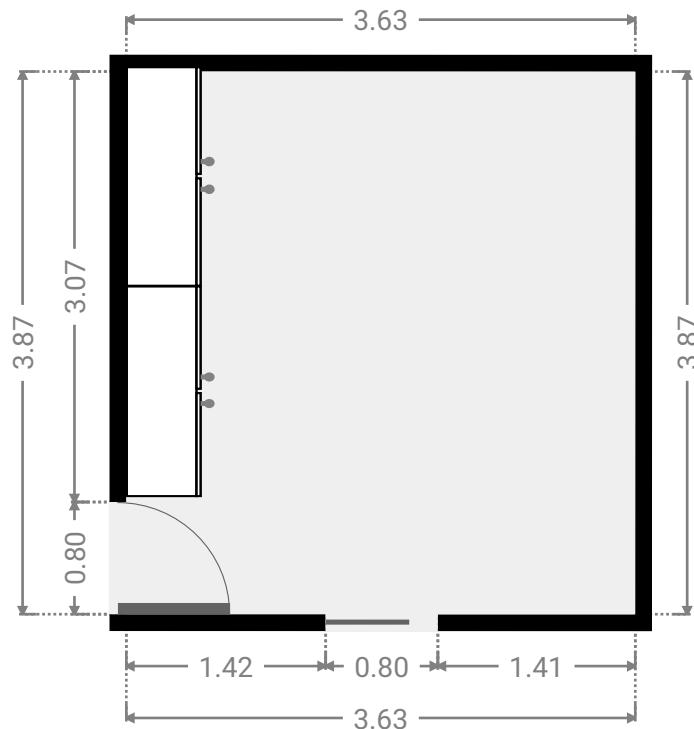
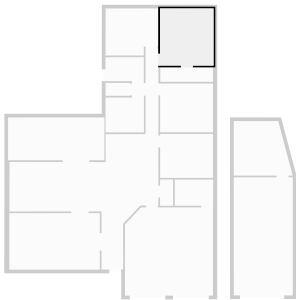

▼ **Bathroom**  
Ground Floor

WIDTH: 3.57 m • LENGTH: 0.98 m  
AREA: 3.50 m<sup>2</sup> • PERIMETER: 9.10 m

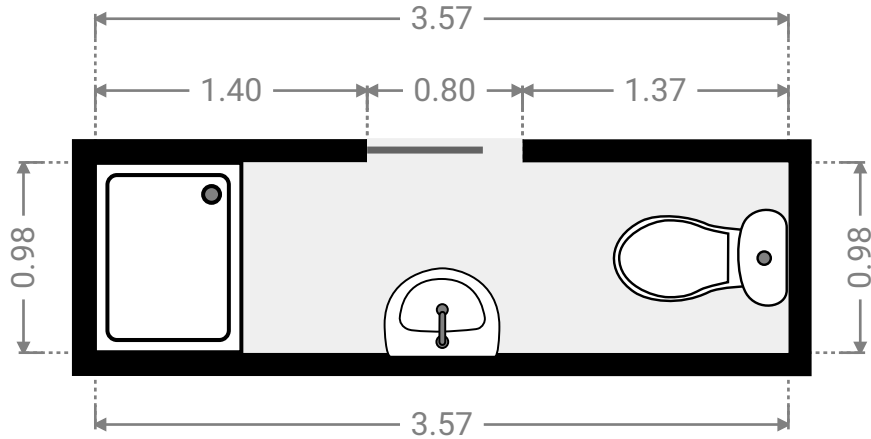
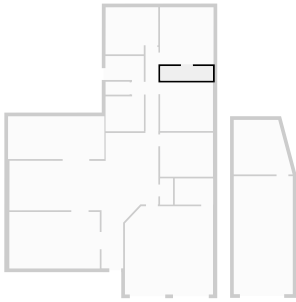

▼ **Laundry Room**  
Ground Floor

WIDTH: 2.60 m • LENGTH: 1.62 m  
AREA: 4.21 m<sup>2</sup> • PERIMETER: 8.44 m

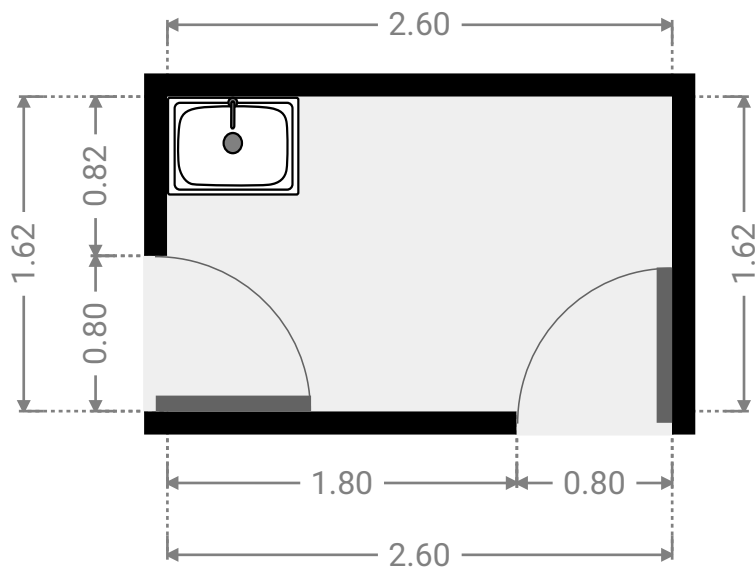
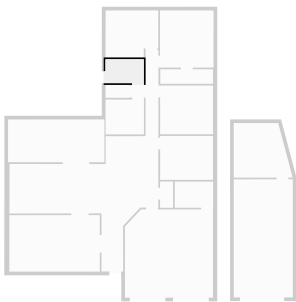

▼ Toilet  
Ground Floor

WIDTH: 1.63 m • LENGTH: 0.87 m  
AREA: 1.42 m<sup>2</sup> • PERIMETER: 5.01 m

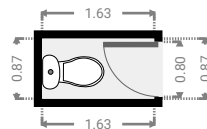
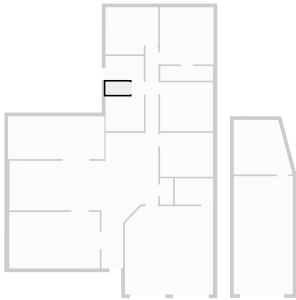

▼ Kitchen/Dining  
Ground Floor

WIDTH: 10.10 m • LENGTH: 9.18 m  
AREA: 46.10 m<sup>2</sup> • PERIMETER: 37.85 m

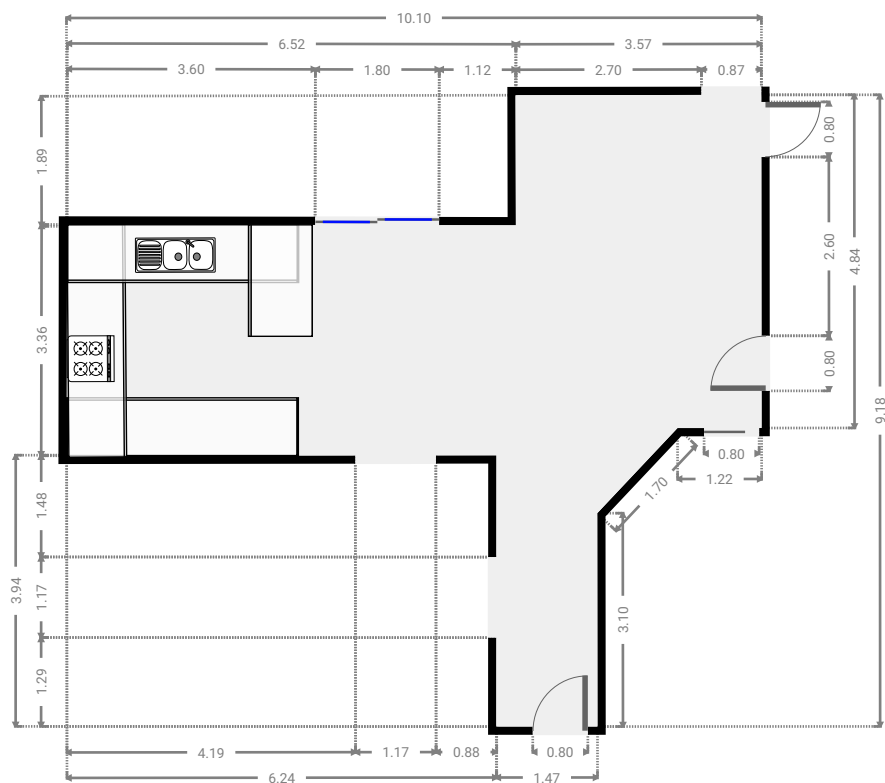
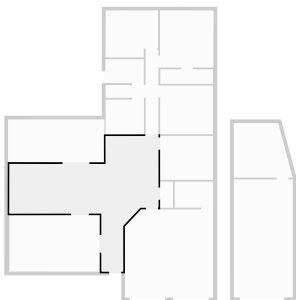

▼ **Bedroom**  
Ground Floor

WIDTH: 3.58 m • LENGTH: 3.30 m  
AREA: 11.81 m<sup>2</sup> • PERIMETER: 13.76 m

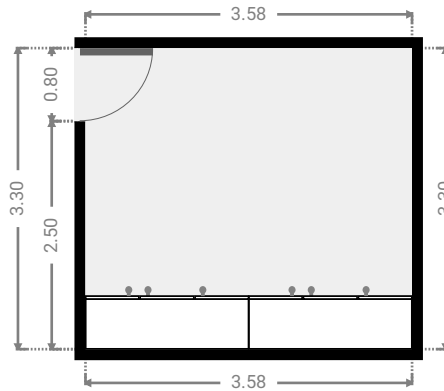
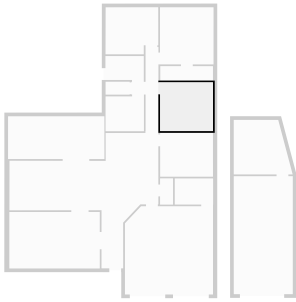

▼ **Hall**  
Ground Floor

WIDTH: 1.83 m • LENGTH: 5.70 m  
AREA: 5.79 m<sup>2</sup> • PERIMETER: 15.06 m

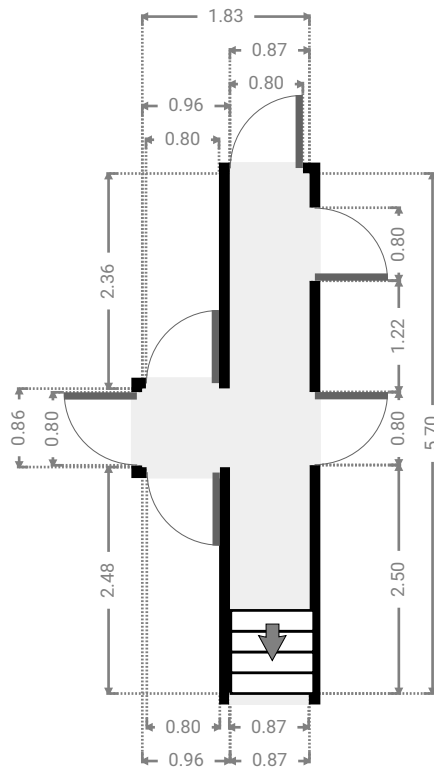
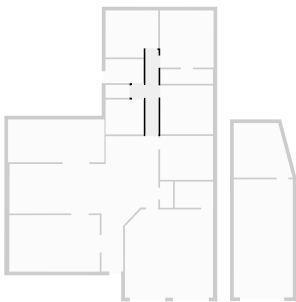



▼ **Bedroom**  
Ground Floor

WIDTH: 3.58 m • LENGTH: 2.98 m  
AREA: 10.67 m<sup>2</sup> • PERIMETER: 13.12 m

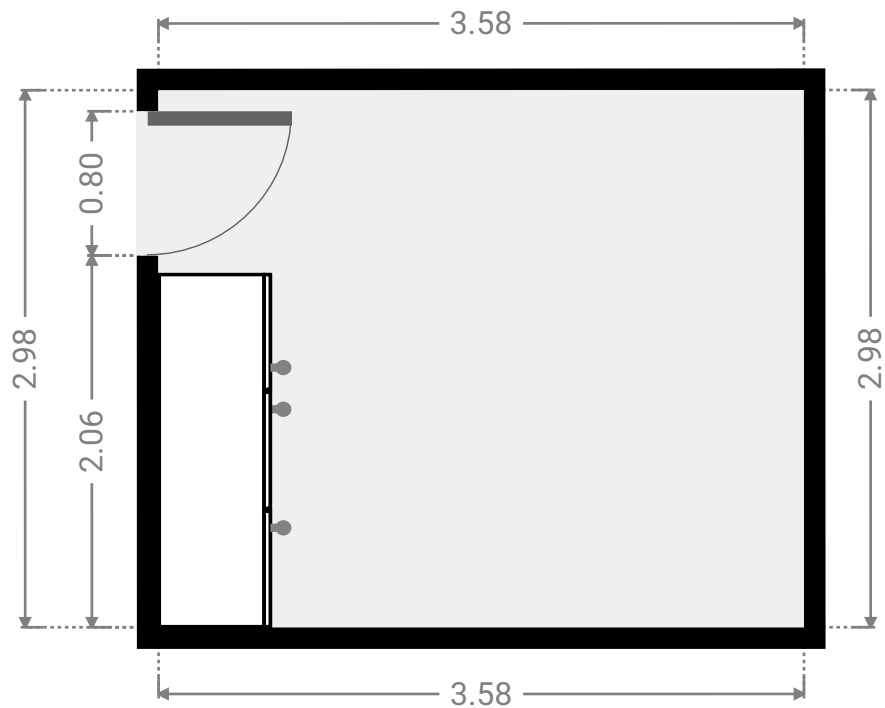
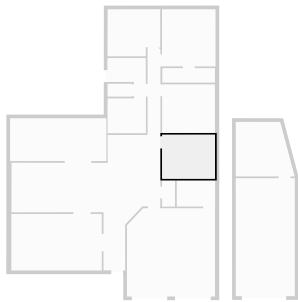

▼ **Workshop**  
Ground Floor

WIDTH: 2.60 m • LENGTH: 1.77 m  
AREA: 4.60 m<sup>2</sup> • PERIMETER: 8.74 m

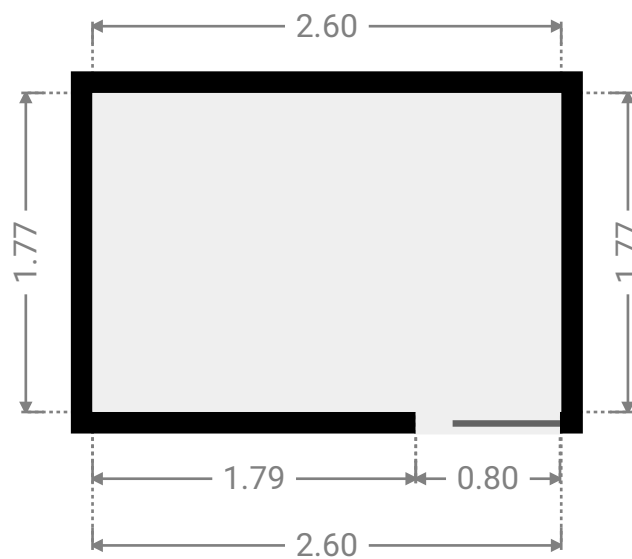
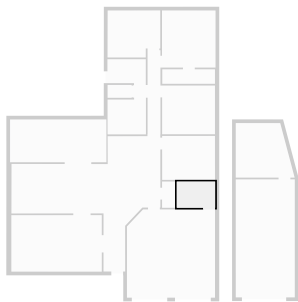

▼ **Garage**  
Ground Floor

WIDTH: 5.97 m • LENGTH: 5.98 m  
AREA: 35.08 m<sup>2</sup> • PERIMETER: 23.24 m

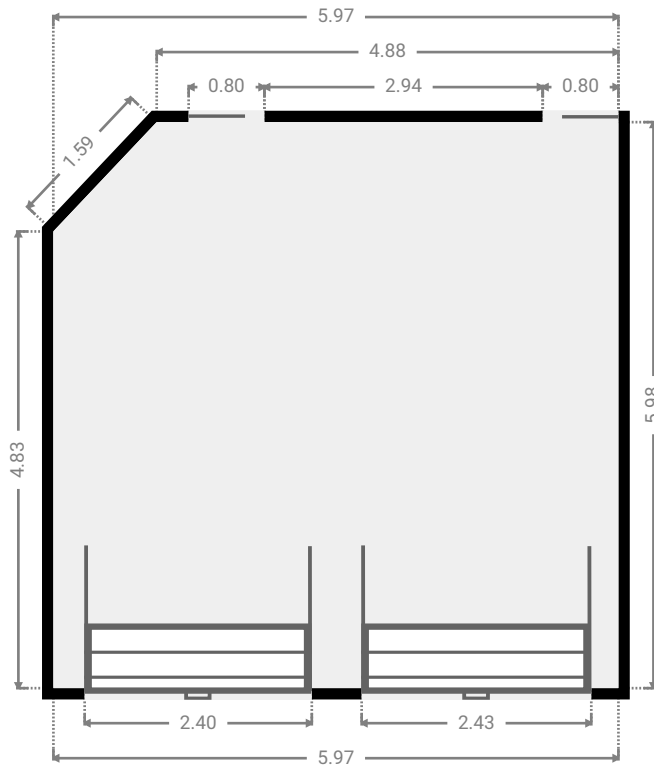
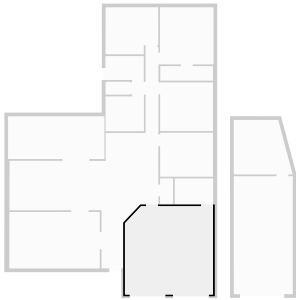

▼ **Closet**  
Ground Floor

WIDTH: 0.88 m • LENGTH: 1.78 m  
AREA: 1.57 m<sup>2</sup> • PERIMETER: 5.32 m

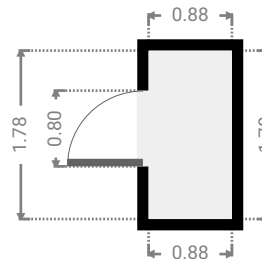
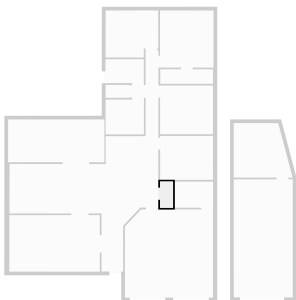

▼ **Living Room**  
Ground Floor

WIDTH: 6.13 m • LENGTH: 3.83 m  
AREA: 23.47 m<sup>2</sup> • PERIMETER: 19.92 m

