

# 40 Peppermint Drive

**SUBMITTED BY**  
Ray White Rockhampton Casey  
stockers@cqoz.com

---

**CREATED ON**  
2022-03-23

---

**Floors**  
1

---

## ▼ Ground Floor



FLOORS: 1

## ▼ Toilet Ground Floor

WIDTH: 1.64 m • LENGTH: 0.95 m  
AREA: 1.55 m<sup>2</sup> • PERIMETER: 5.15 m

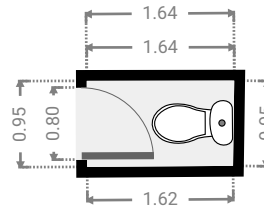

## ▼ Pool Ground Floor

WIDTH: 9.04 m • LENGTH: 5.70 m  
AREA: 43.92 m<sup>2</sup> • PERIMETER: 28.75 m

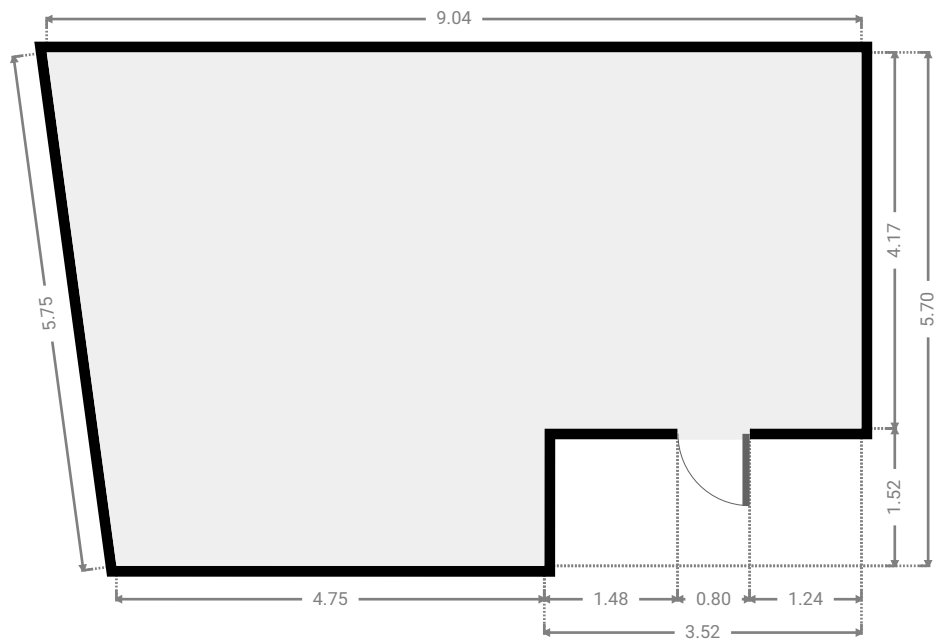
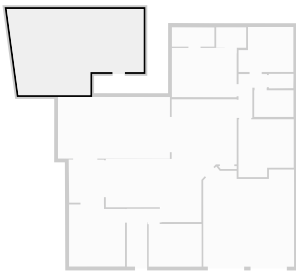

FLOORS: 1

## ▼ Other Ground Floor

WIDTH: 7.40 m • LENGTH: 4.08 m  
AREA: 30.16 m<sup>2</sup> • PERIMETER: 22.95 m

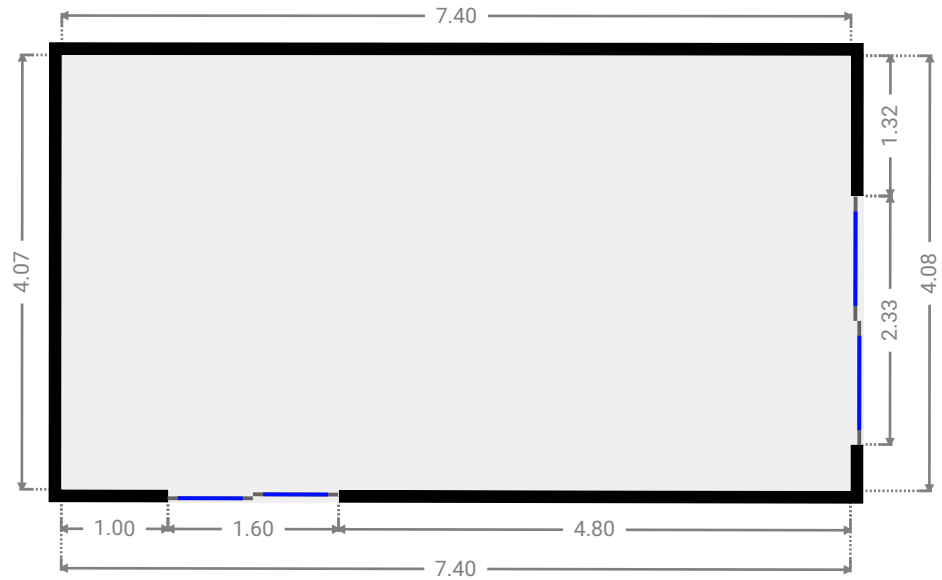
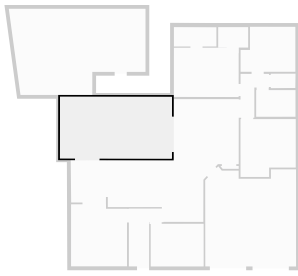

## ▼ Dining Room Ground Floor

WIDTH: 2.34 m • LENGTH: 2.85 m  
AREA: 6.60 m<sup>2</sup> • PERIMETER: 10.33 m

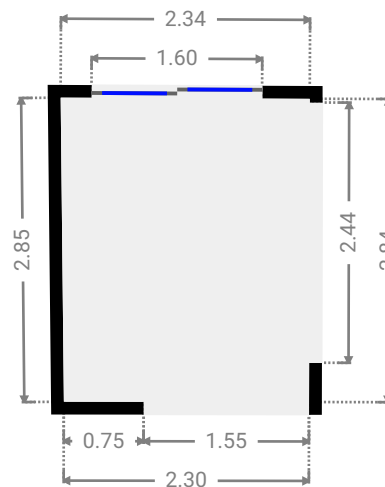
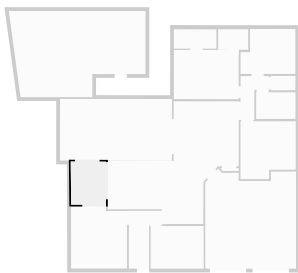

FLOORS: 1

## ▼ Living Room Ground Floor

WIDTH: 3.70 m • LENGTH: 4.10 m  
AREA: 14.76 m<sup>2</sup> • PERIMETER: 15.60 m

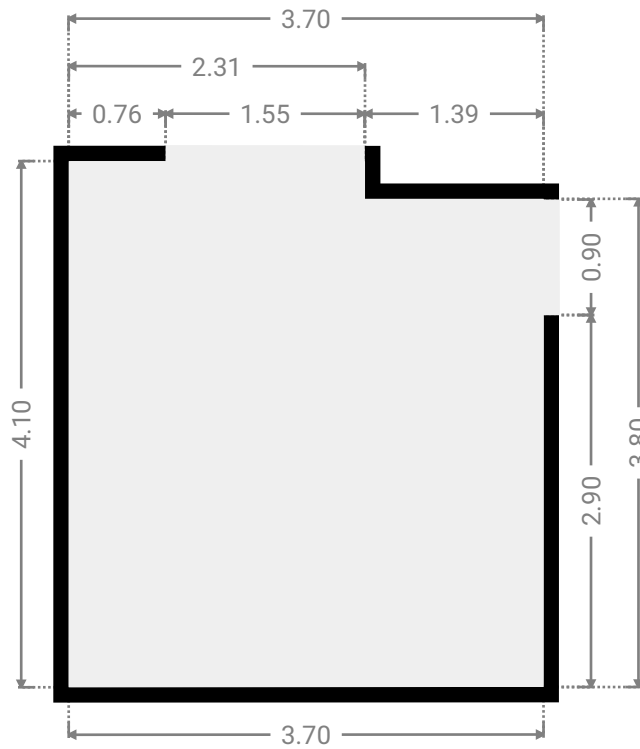
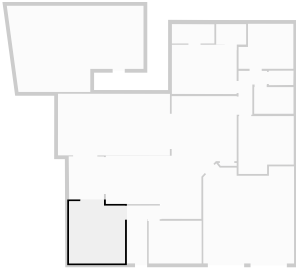

## ▼ Bathroom Ground Floor

WIDTH: 2.81 m • LENGTH: 1.28 m  
AREA: 3.58 m<sup>2</sup> • PERIMETER: 8.17 m

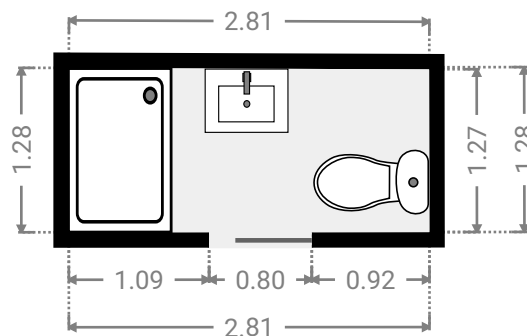

FLOORS: 1

## ▼ Closet Ground Floor

WIDTH: 1.98 m • LENGTH: 1.35 m  
AREA: 2.67 m<sup>2</sup> • PERIMETER: 6.66 m

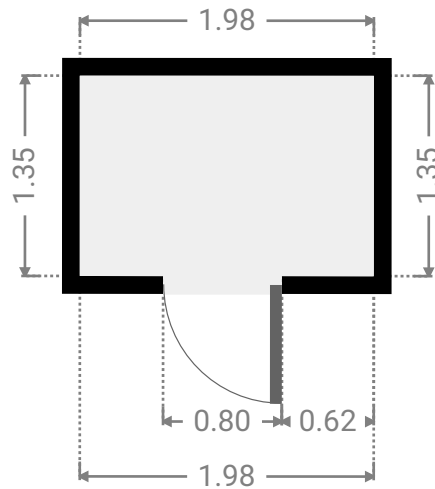

## ▼ Primary Bedroom Ground Floor

WIDTH: 4.28 m • LENGTH: 3.26 m  
AREA: 13.93 m<sup>2</sup> • PERIMETER: 15.07 m

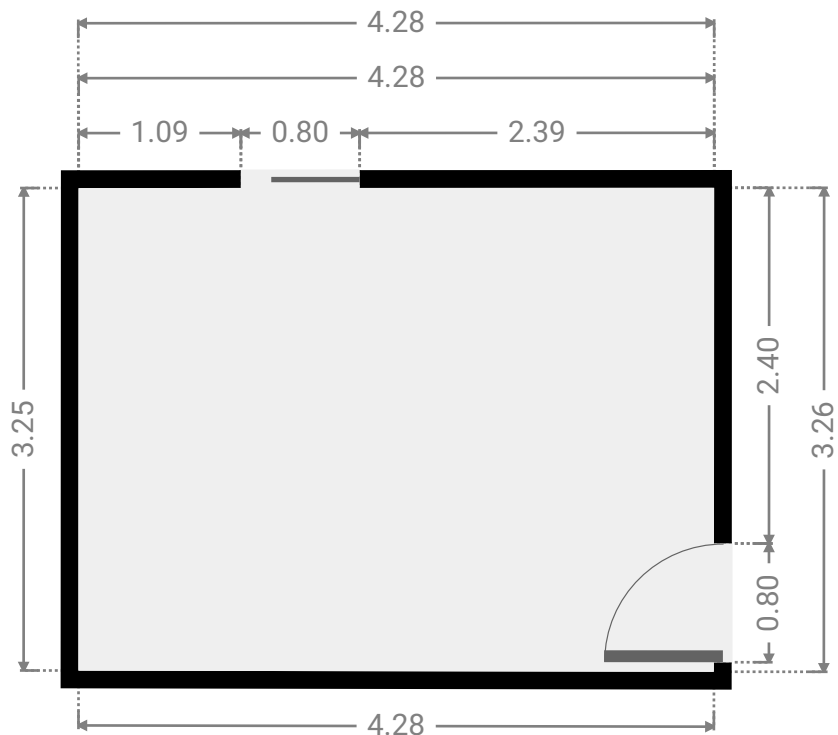
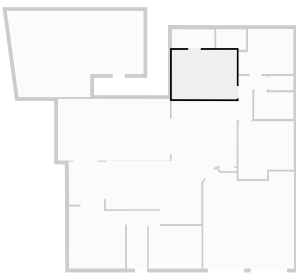

FLOORS: 1

▼ **Bedroom**  
Ground Floor

WIDTH: 3.62 m • LENGTH: 2.97 m  
AREA: 9.81 m<sup>2</sup> • PERIMETER: 13.18 m

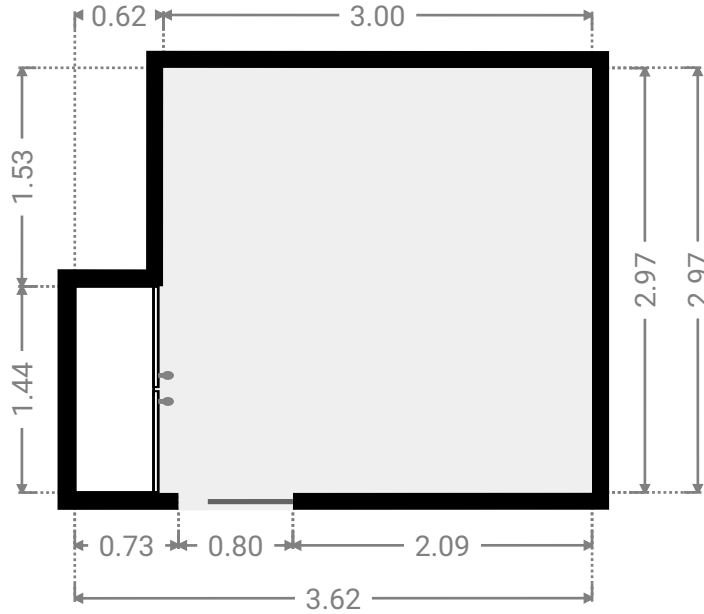
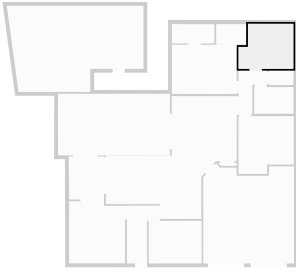

▼ **Hall**  
Ground Floor

WIDTH: 2.17 m • LENGTH: 3.82 m  
AREA: 5.87 m<sup>2</sup> • PERIMETER: 11.99 m

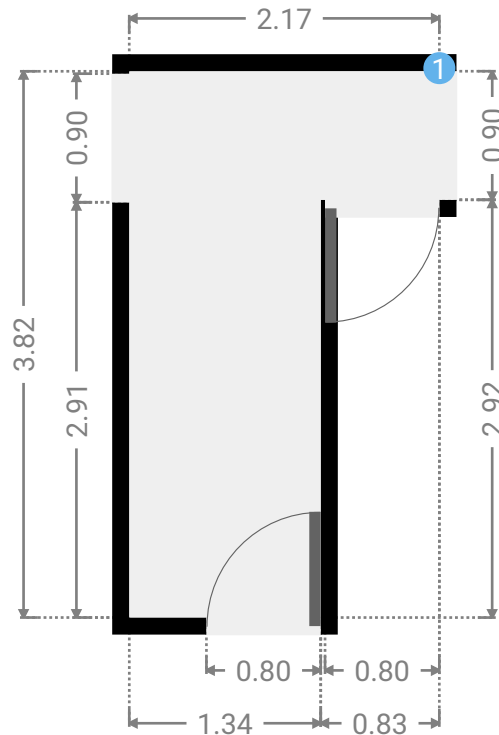

▼ **Hall**/Ground Floor

1 **OPENING**

Height  
0.00 m





FLOORS: 1

▼ Bathroom  
Ground Floor

WIDTH: 2.60 m • LENGTH: 1.76 m  
AREA: 4.58 m<sup>2</sup> • PERIMETER: 8.72 m

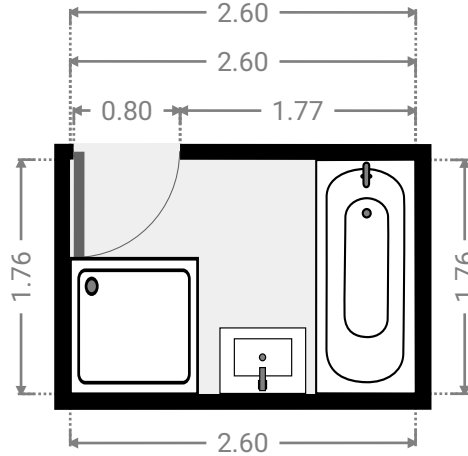
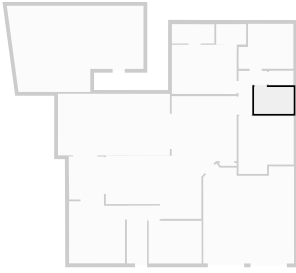

▼ Hall  
Ground Floor

WIDTH: 1.88 m • LENGTH: 2.90 m  
AREA: 3.51 m<sup>2</sup> • PERIMETER: 9.56 m

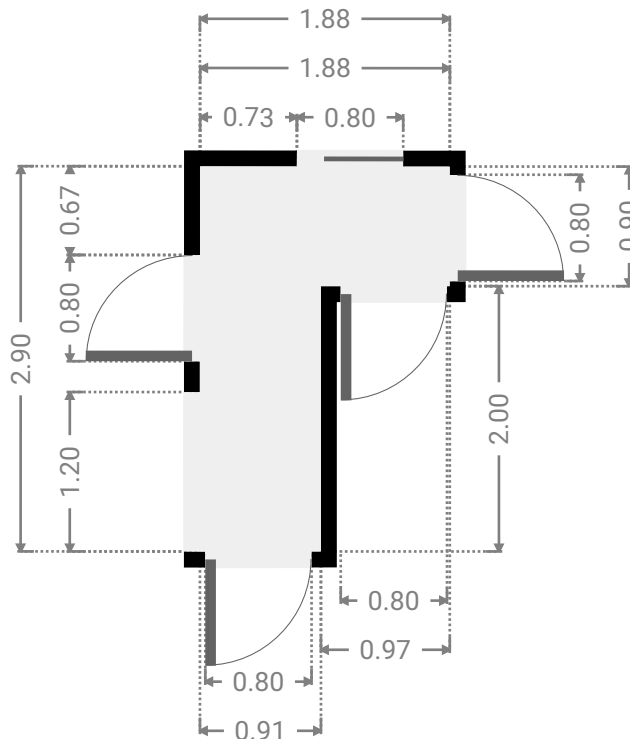

## ▼ Bedroom Ground Floor

WIDTH: 3.65 m • LENGTH: 3.82 m  
AREA: 12.87 m<sup>2</sup> • PERIMETER: 14.95 m

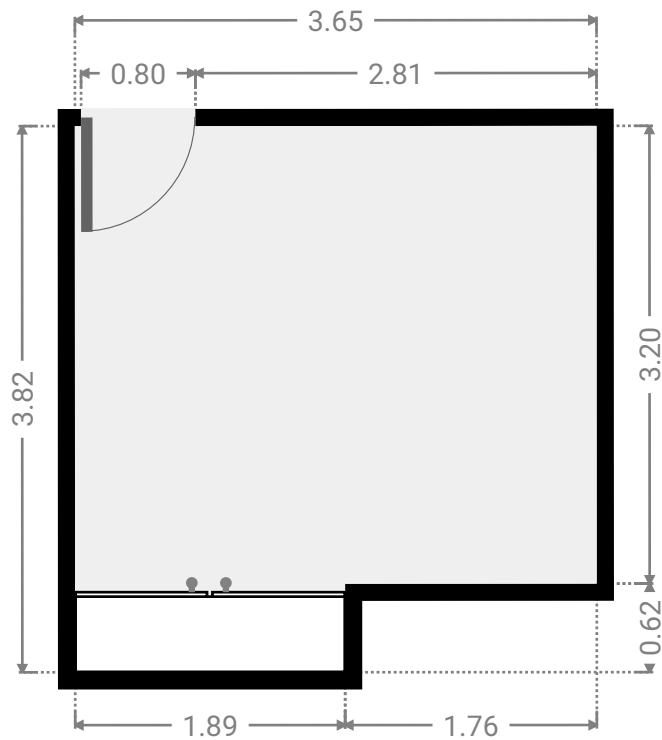

## ▼ Closet Ground Floor

WIDTH: 1.22 m • LENGTH: 0.19 m  
AREA: 0.22 m<sup>2</sup> • PERIMETER: 2.72 m

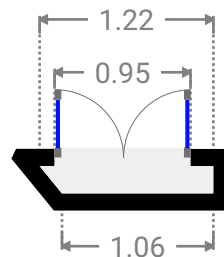
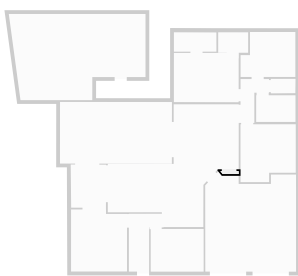

FLOORS: 1

## ▼ Garage Ground Floor

WIDTH: 6.01 m • LENGTH: 6.62 m  
AREA: 36.90 m<sup>2</sup> • PERIMETER: 25.82 m

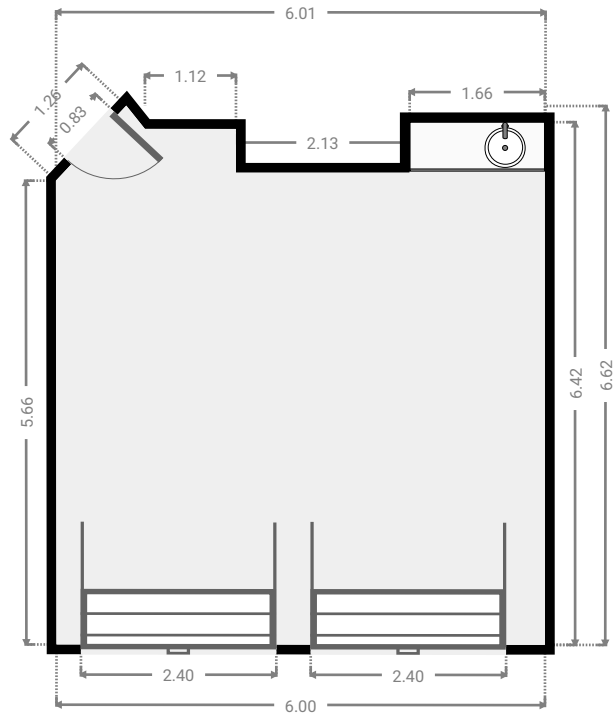
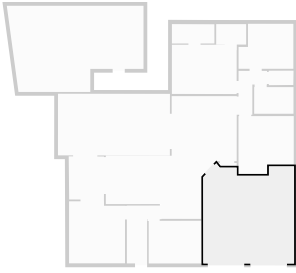

## ▼ Kitchen Ground Floor

WIDTH: 8.66 m • LENGTH: 8.12 m  
AREA: 41.04 m<sup>2</sup> • PERIMETER: 32.96 m

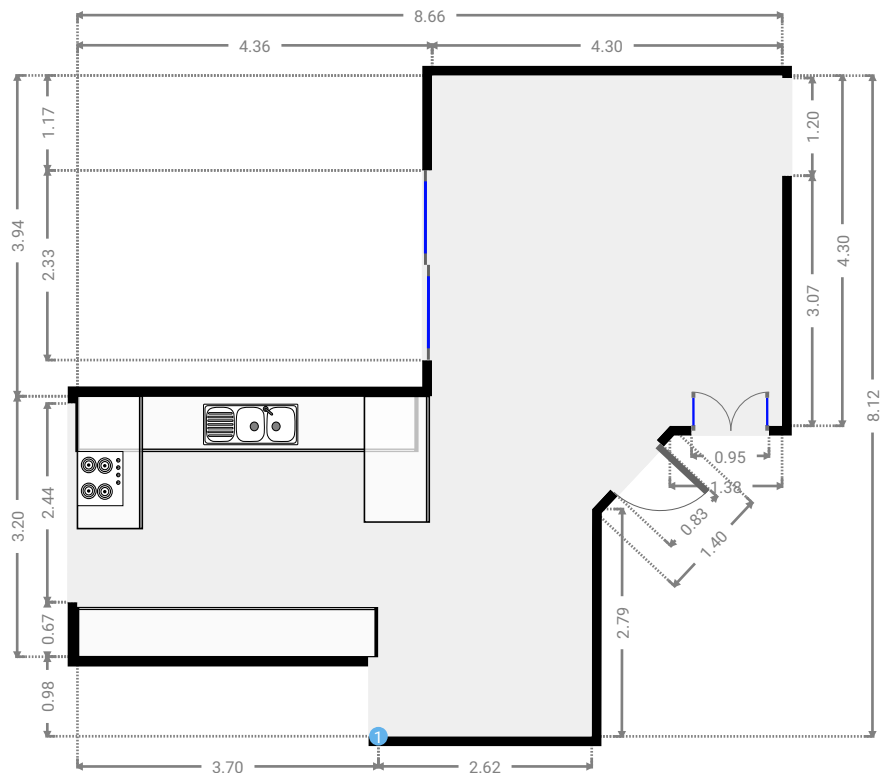
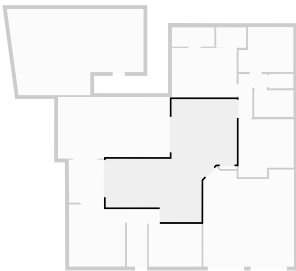

FLOORS: 1

## ▼ Bedroom Ground Floor

WIDTH: 3.50 m • LENGTH: 2.82 m  
AREA: 9.87 m<sup>2</sup> • PERIMETER: 12.64 m

