

# 4 Standish Street

Created on  
2021-07-20

Floors  
2

▼ Ground Floor



## ▼ Rumpus Ground Floor

WIDTH: 6.32 m • LENGTH: 6.80 m  
AREA: 42.98 m<sup>2</sup> • PERIMETER: 26.24 m

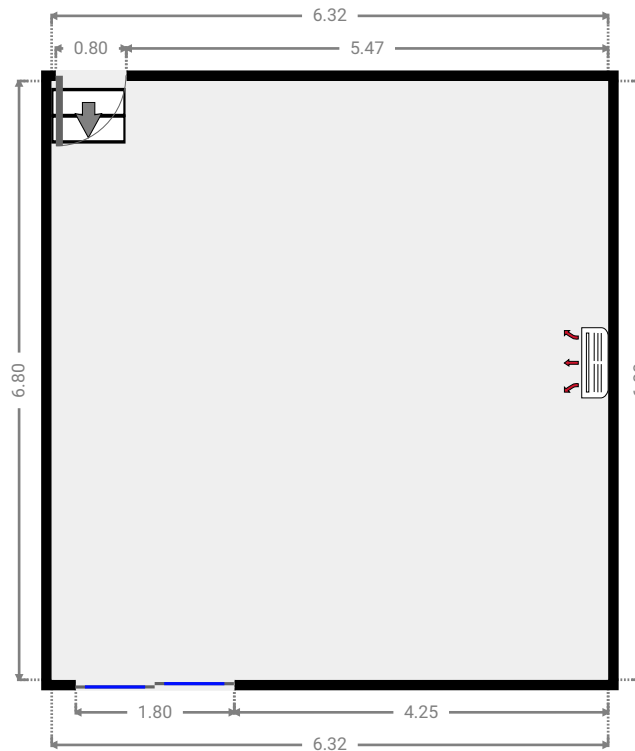
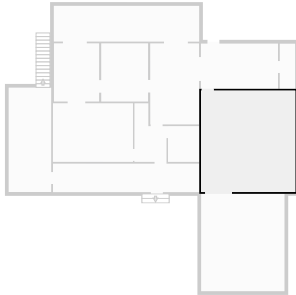

## ▼ Living Room Ground Floor

WIDTH: 5.17 m • LENGTH: 3.03 m  
AREA: 15.67 m<sup>2</sup> • PERIMETER: 16.40 m

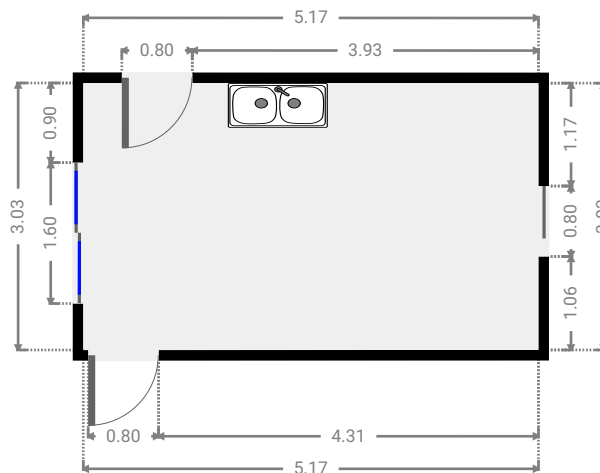
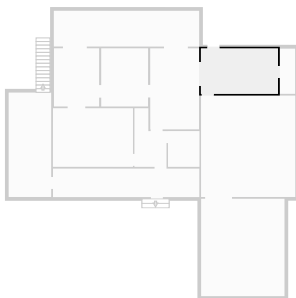

▼ Bathroom  
Ground Floor

WIDTH: 1.03 m • LENGTH: 3.03 m  
AREA: 3.12 m<sup>2</sup> • PERIMETER: 8.12 m

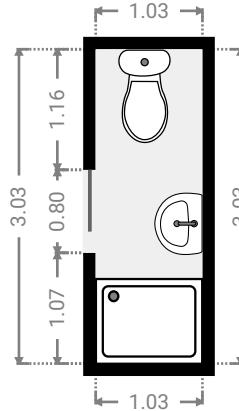
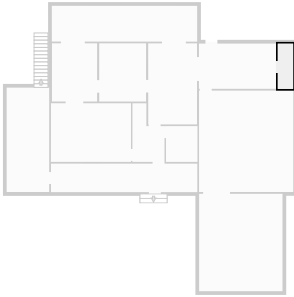

▼ Living Room  
Ground Floor

WIDTH: 3.28 m • LENGTH: 5.43 m  
AREA: 17.78 m<sup>2</sup> • PERIMETER: 17.41 m

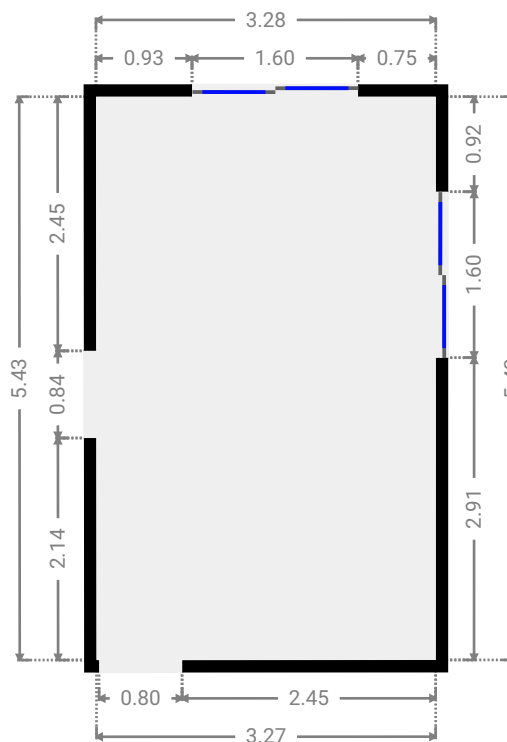
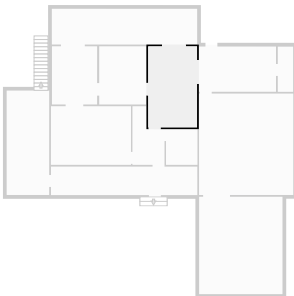

▼ Study  
Ground Floor

WIDTH: 2.11 m • LENGTH: 2.40 m  
AREA: 5.06 m<sup>2</sup> • PERIMETER: 9.02 m

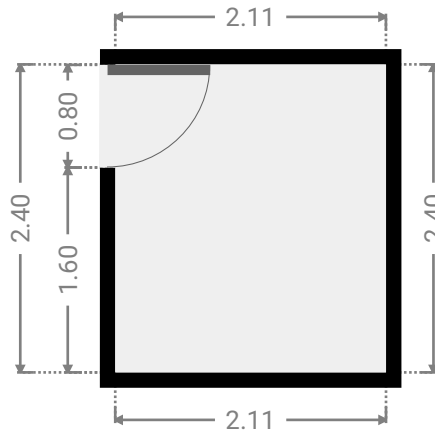
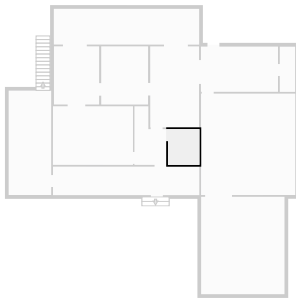

▼ Stairway  
Ground Floor

WIDTH: 2.15 m • LENGTH: 3.93 m  
AREA: 6.58 m<sup>2</sup> • PERIMETER: 12.16 m

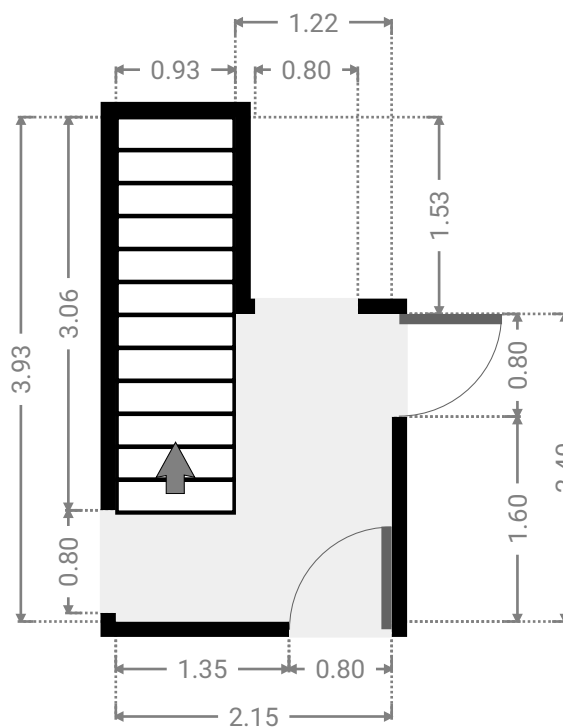
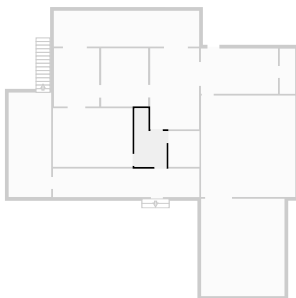

▼ **Living Room**  
Ground Floor

WIDTH: 5.37 m • LENGTH: 3.93 m  
AREA: 21.10 m<sup>2</sup> • PERIMETER: 18.60 m

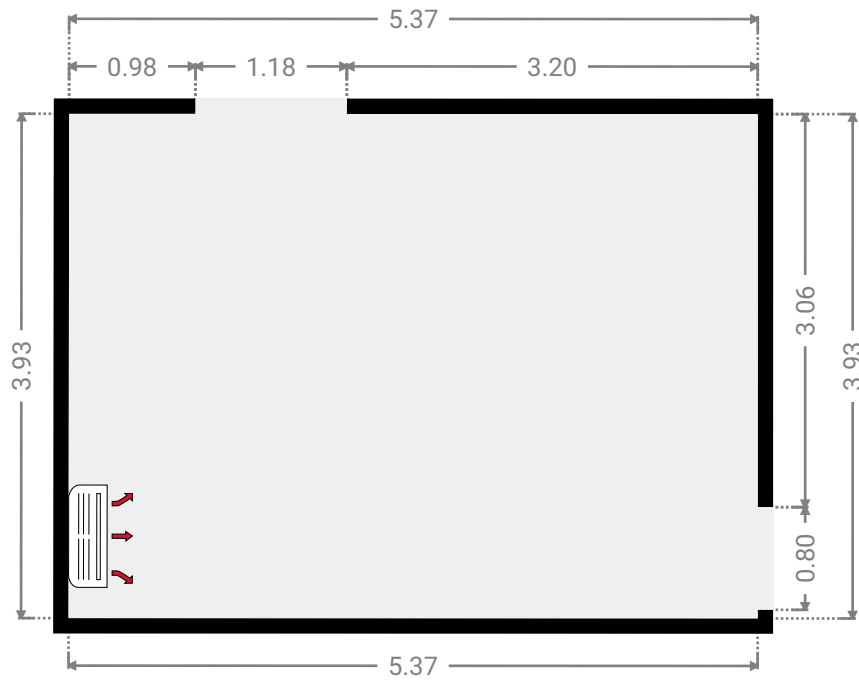
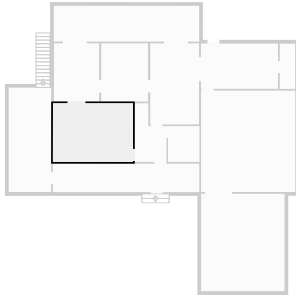

▼ **Dining Room**  
Ground Floor

WIDTH: 3.03 m • LENGTH: 3.90 m  
AREA: 11.82 m<sup>2</sup> • PERIMETER: 13.86 m

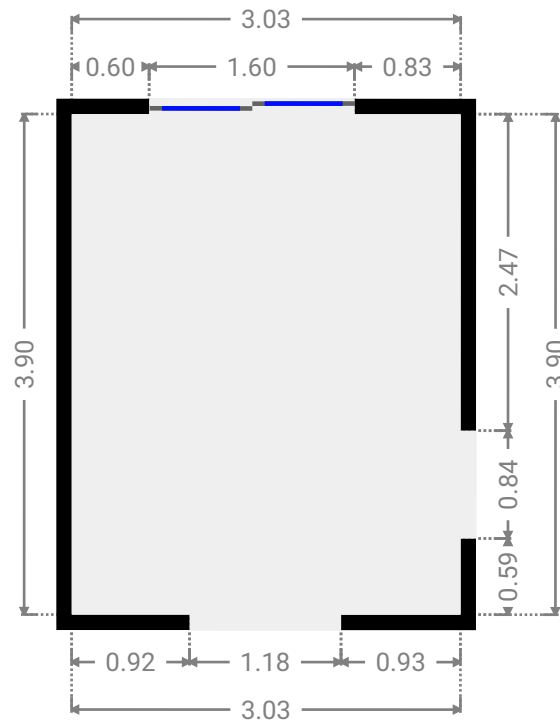
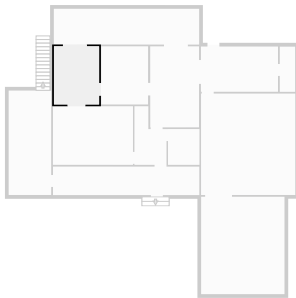

## ▼ Kitchen Ground Floor

WIDTH: 3.14 m • LENGTH: 3.90 m  
AREA: 12.25 m<sup>2</sup> • PERIMETER: 14.08 m

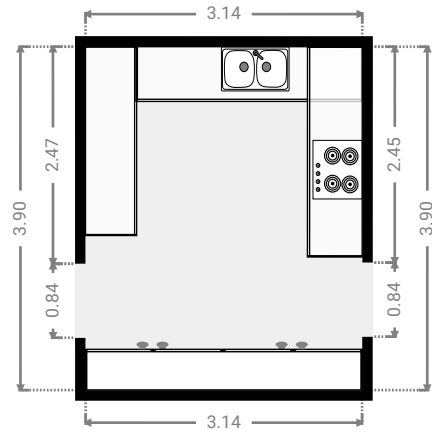
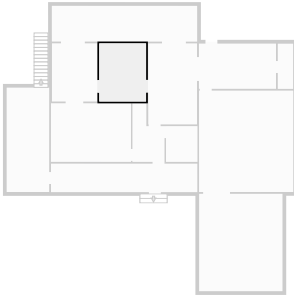

## ▼ Other Ground Floor

WIDTH: 9.75 m • LENGTH: 2.40 m  
AREA: 23.36 m<sup>2</sup> • PERIMETER: 24.29 m

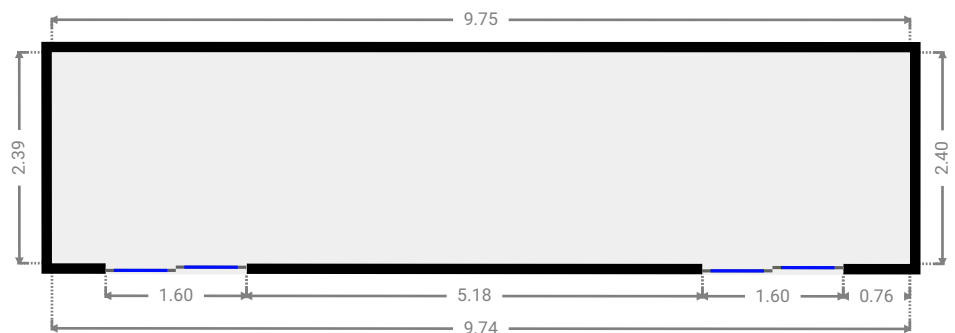
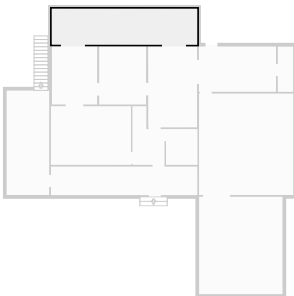

▼ Other  
Ground Floor

WIDTH: 9.81 m • LENGTH: 1.91 m  
AREA: 18.73 m<sup>2</sup> • PERIMETER: 23.44 m

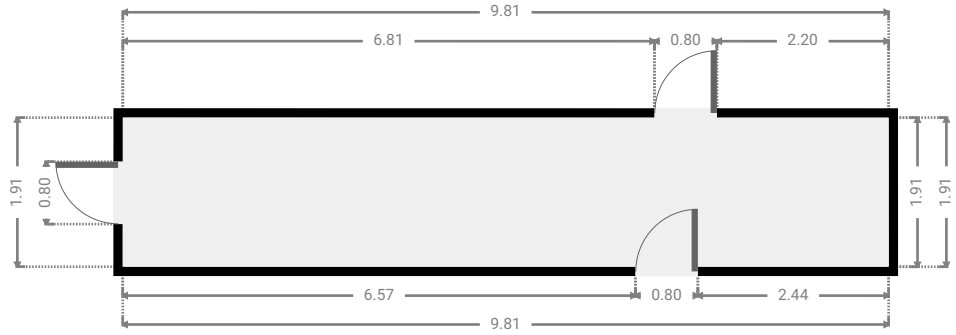
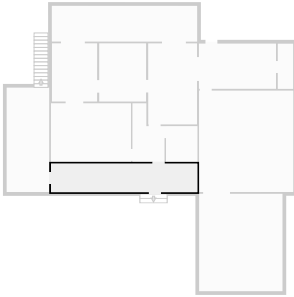

▼ Garage  
Ground Floor

WIDTH: 5.59 m • LENGTH: 6.53 m  
AREA: 36.50 m<sup>2</sup> • PERIMETER: 24.24 m

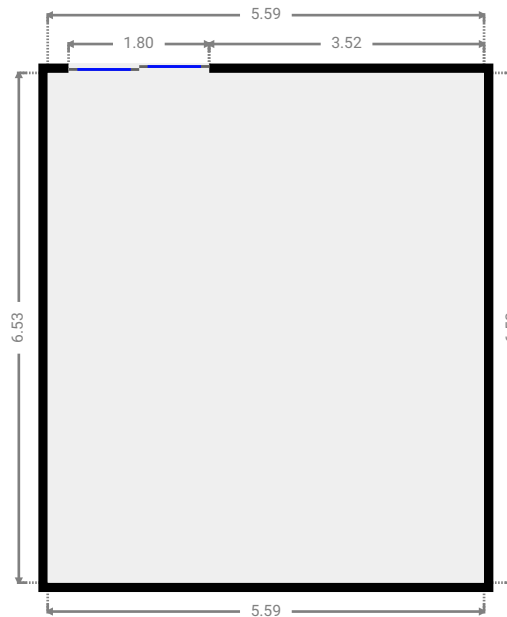
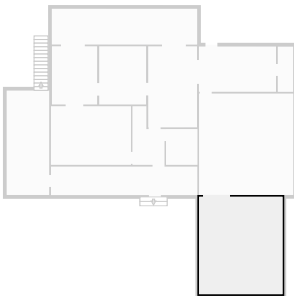



## ▼ Garage Ground Floor

WIDTH: 2.85 m • LENGTH: 7.00 m  
AREA: 19.95 m<sup>2</sup> • PERIMETER: 19.70 m

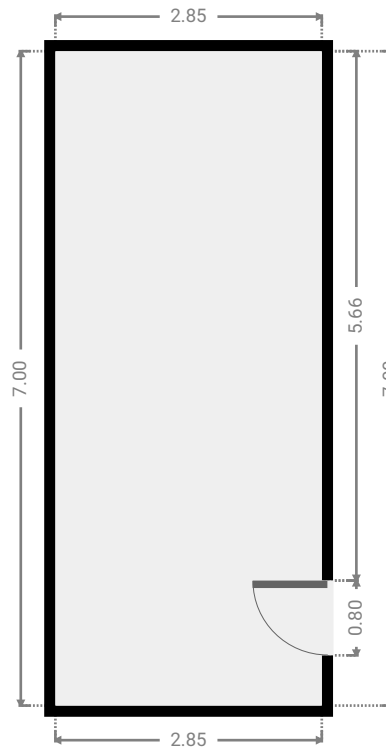
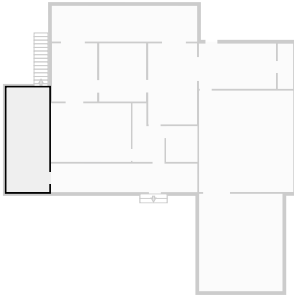

## ▼ 1st Floor

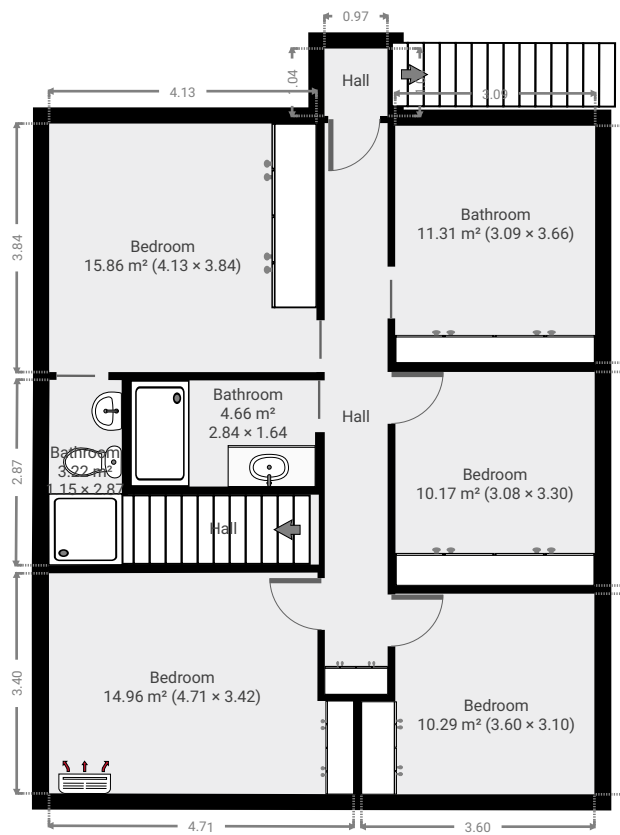

▼ **Bedroom**  
1st Floor

WIDTH: 3.44 m • LENGTH: 4.65 m  
AREA: 14.96 m<sup>2</sup> • PERIMETER: 16.24 m

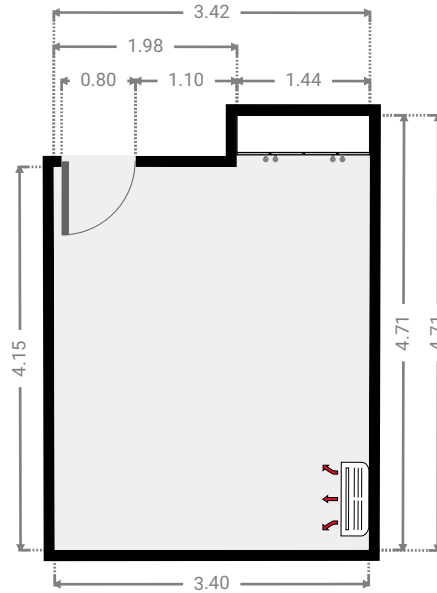
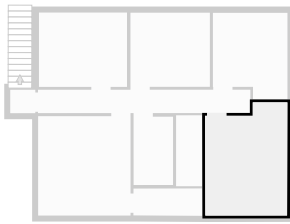

▼ **Hall**  
1st Floor

WIDTH: 8.83 m • LENGTH: 0.97 m  
AREA: 8.57 m<sup>2</sup> • PERIMETER: 19.60 m

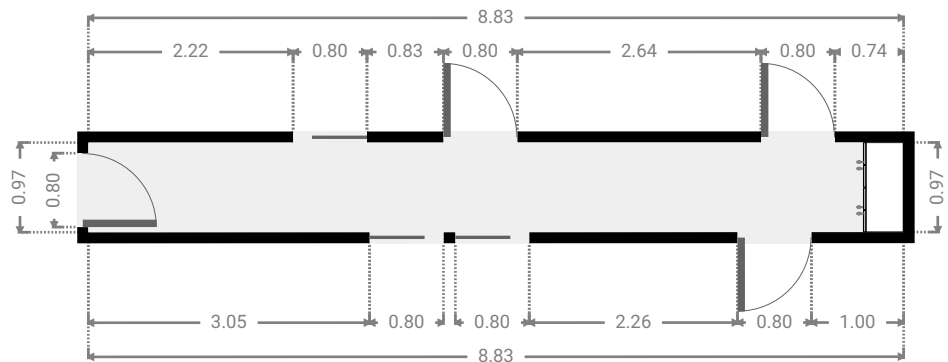
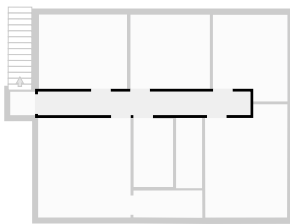

▼ **Bedroom**  
1st Floor

WIDTH: 3.10 m • LENGTH: 3.60 m  
AREA: 10.29 m<sup>2</sup> • PERIMETER: 13.40 m

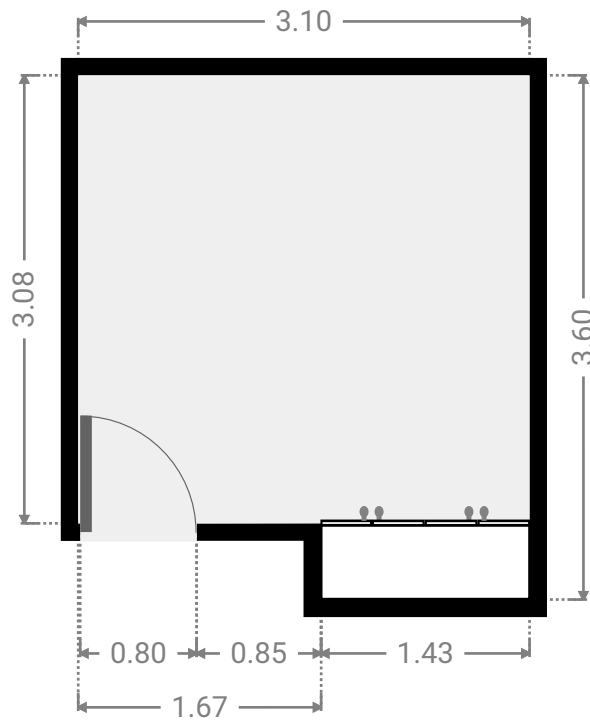
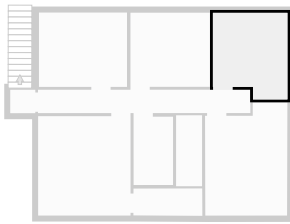

▼ **Hall**  
1st Floor

WIDTH: 1.08 m • LENGTH: 2.95 m  
AREA: 3.19 m<sup>2</sup> • PERIMETER: 8.06 m

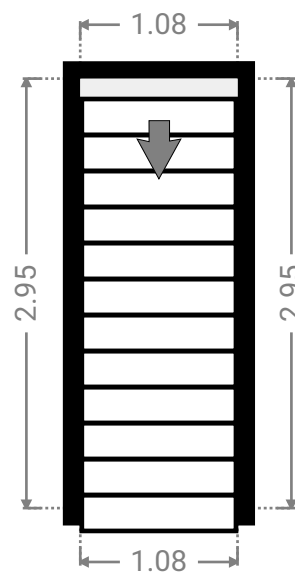
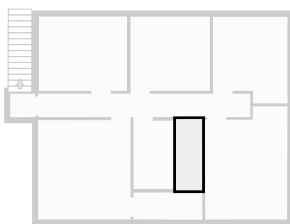

▼ **Bathroom**  
1st Floor

WIDTH: 1.64 m • LENGTH: 2.84 m  
AREA: 4.66 m<sup>2</sup> • PERIMETER: 8.96 m

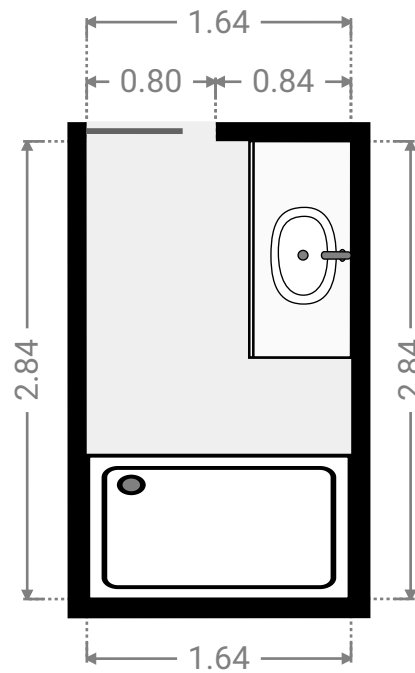
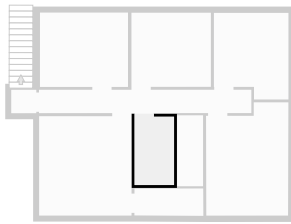

▼ **Bedroom**  
1st Floor

WIDTH: 3.30 m • LENGTH: 3.08 m  
AREA: 10.17 m<sup>2</sup> • PERIMETER: 12.76 m

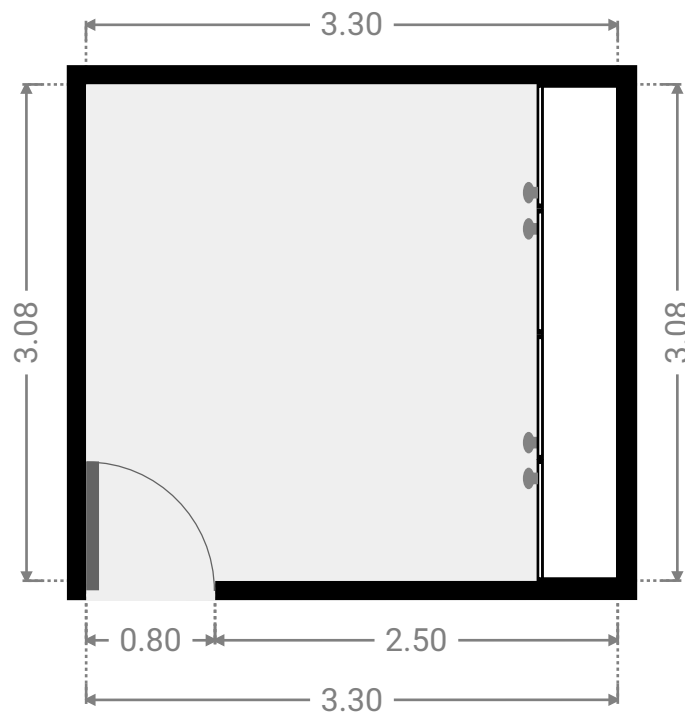
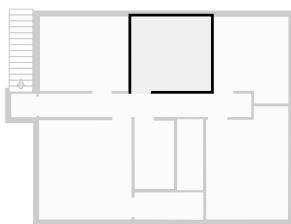

▼ **Bedroom**  
1st Floor

WIDTH: 3.84 m • LENGTH: 4.13 m  
AREA: 15.86 m<sup>2</sup> • PERIMETER: 15.94 m

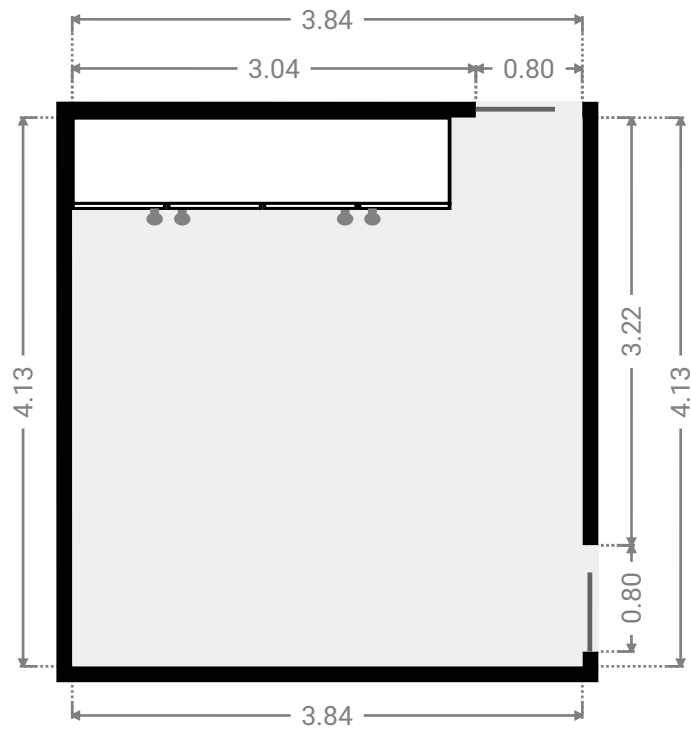
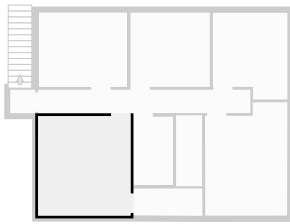

▼ **Bathroom**  
1st Floor

WIDTH: 2.87 m • LENGTH: 1.15 m  
AREA: 3.22 m<sup>2</sup> • PERIMETER: 7.97 m

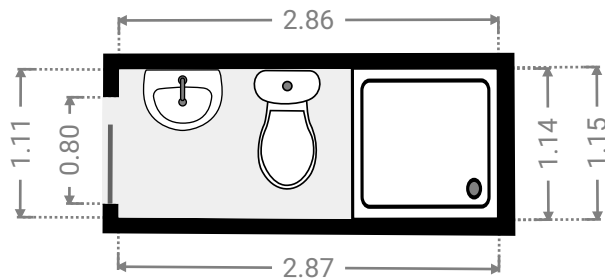
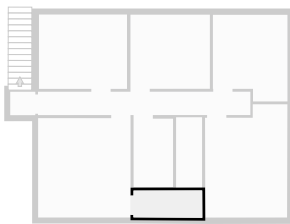

▼ **Bathroom**  
1st Floor

WIDTH: 3.66 m • LENGTH: 3.09 m  
AREA: 11.31 m<sup>2</sup> • PERIMETER: 13.50 m

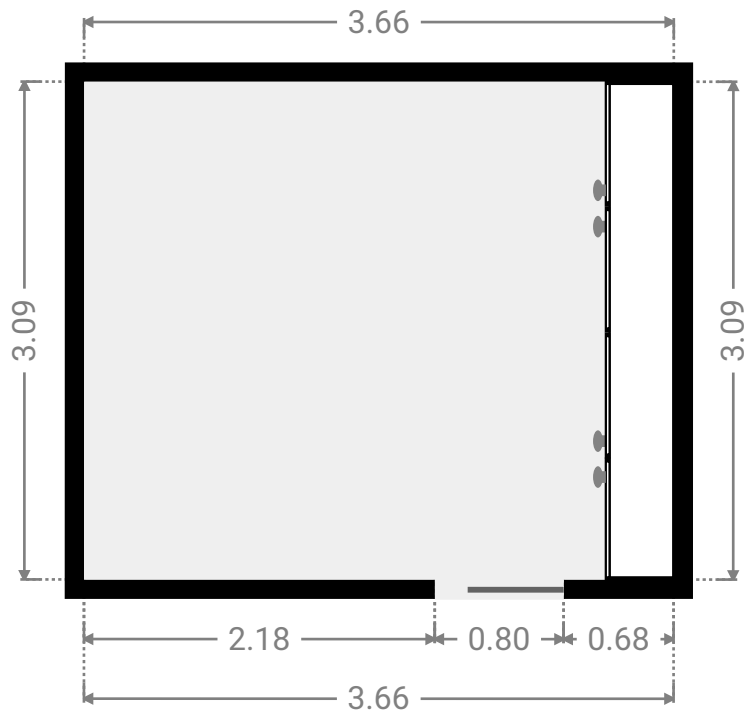
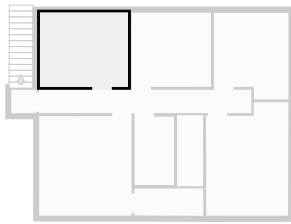

▼ **Hall**  
1st Floor

WIDTH: 1.04 m • LENGTH: 0.97 m  
AREA: 1.01 m<sup>2</sup> • PERIMETER: 4.03 m

