

4 Laver Street

SUBMITTED BY
Ray White Rockhampton Casey
stockers@cqoz.com

CREATED ON
2022-03-14

Floors
2

▼ Ground Floor

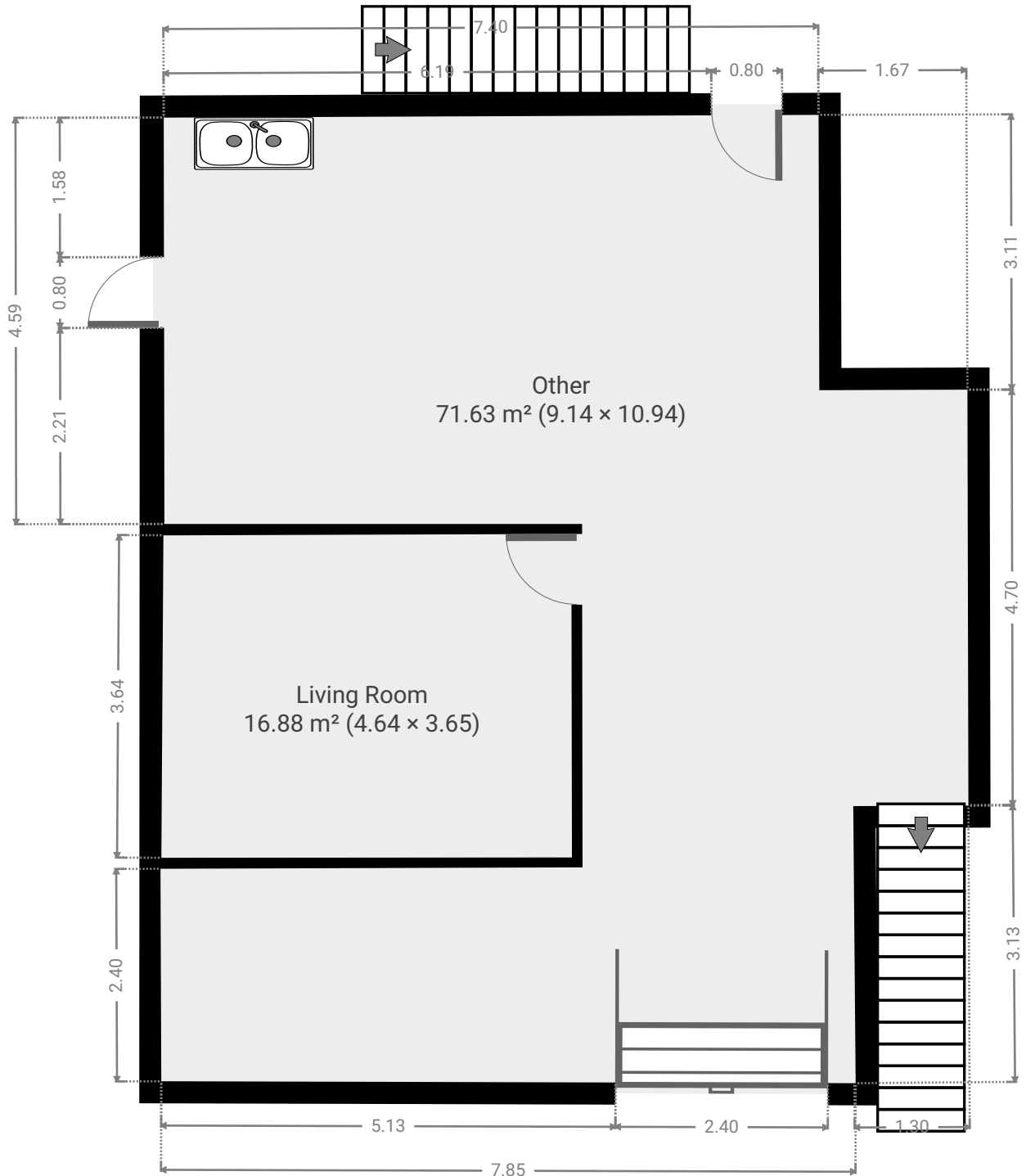

▼ Other Ground Floor

WIDTH: 9.14 m • LENGTH: 10.94 m
AREA: 71.63 m² • PERIMETER: 49.52 m

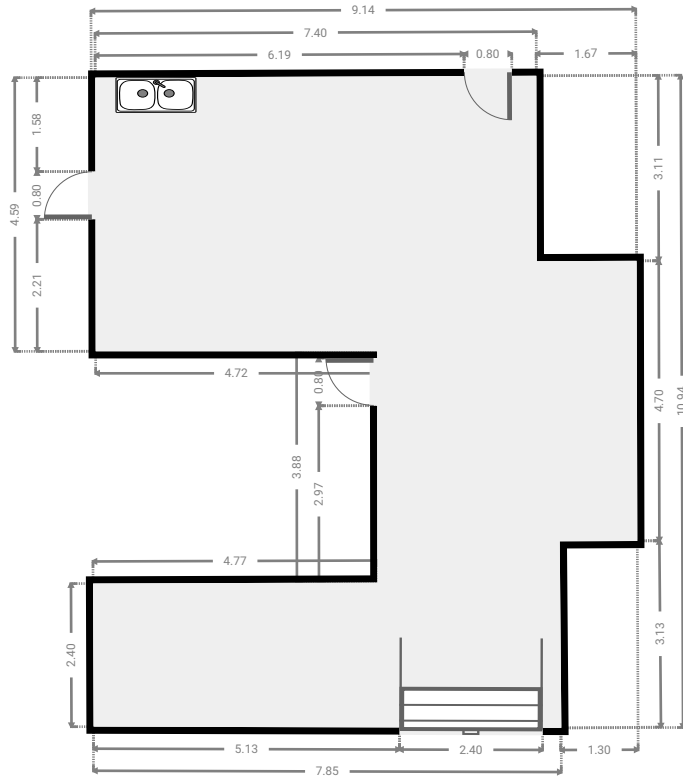
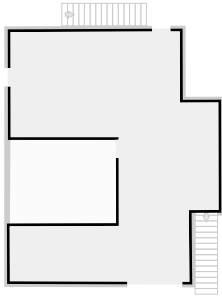

▼ Living Room Ground Floor

WIDTH: 4.64 m • LENGTH: 3.65 m
AREA: 16.88 m² • PERIMETER: 16.55 m

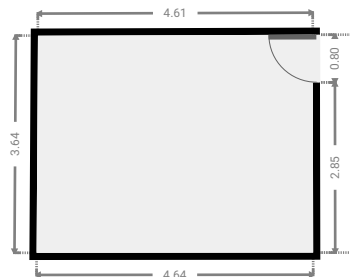
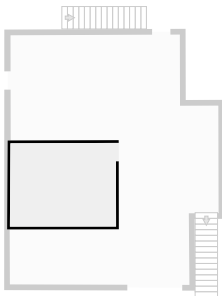

▼ 1st Floor

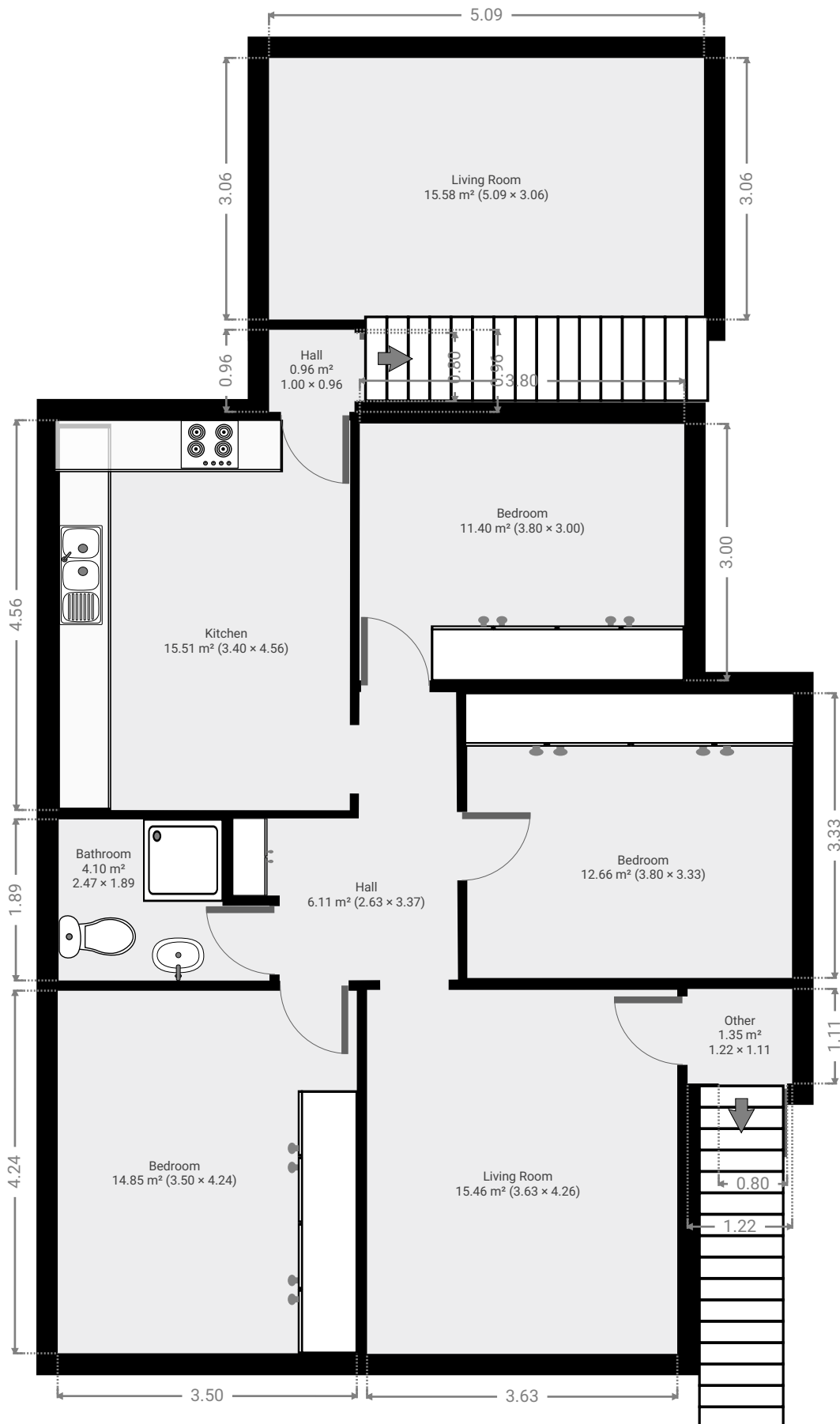

▼ Living Room 1st Floor

WIDTH: 3.63 m • LENGTH: 4.26 m
AREA: 15.46 m² • PERIMETER: 15.78 m

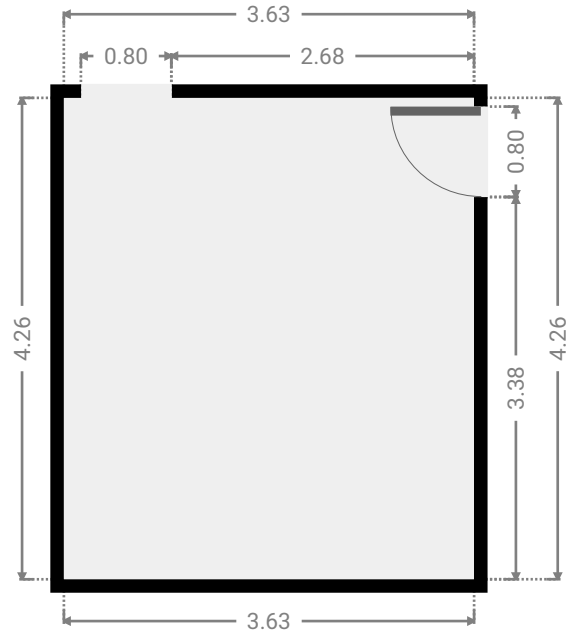
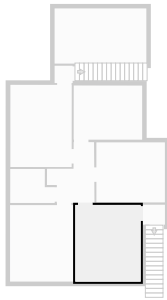

▼ Hall 1st Floor

WIDTH: 2.63 m • LENGTH: 3.37 m
AREA: 6.11 m² • PERIMETER: 11.98 m

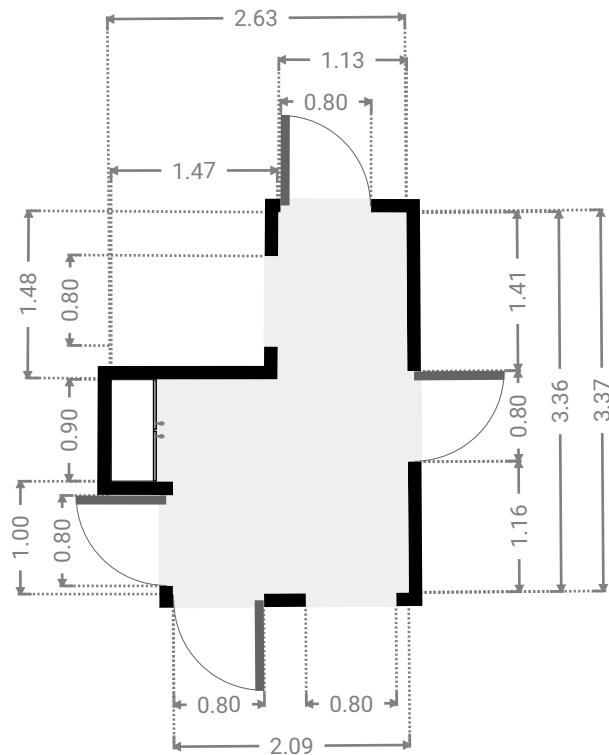
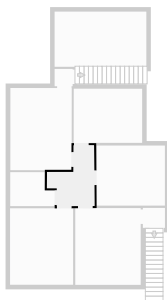

▼ Bedroom 1st Floor

WIDTH: 3.50 m • LENGTH: 4.24 m
AREA: 14.85 m² • PERIMETER: 15.48 m

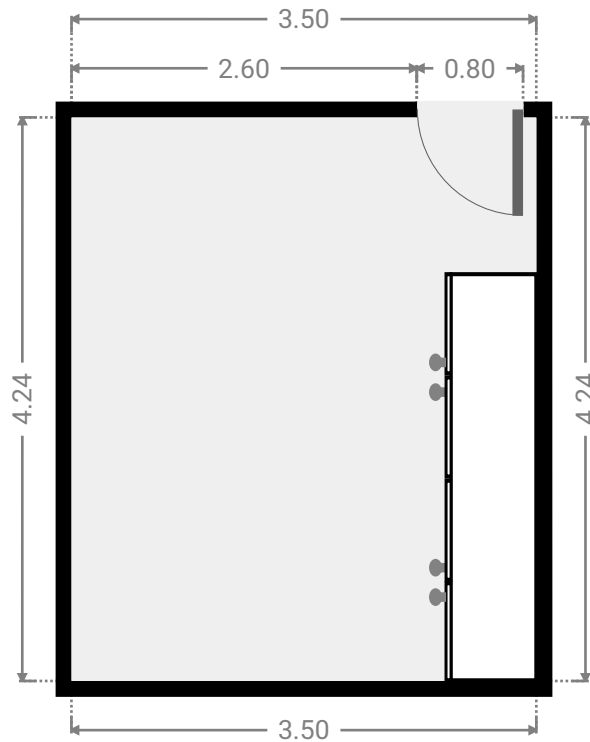
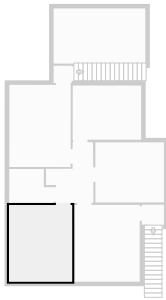

▼ Bathroom 1st Floor

WIDTH: 2.47 m • LENGTH: 1.89 m
AREA: 4.10 m² • PERIMETER: 8.71 m

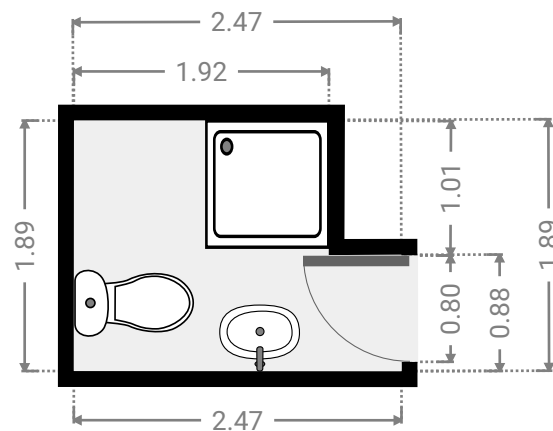
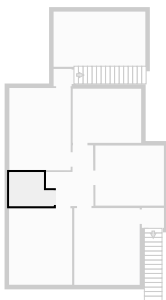

▼ Bedroom 1st Floor

WIDTH: 3.80 m • LENGTH: 3.33 m
AREA: 12.66 m² • PERIMETER: 14.26 m

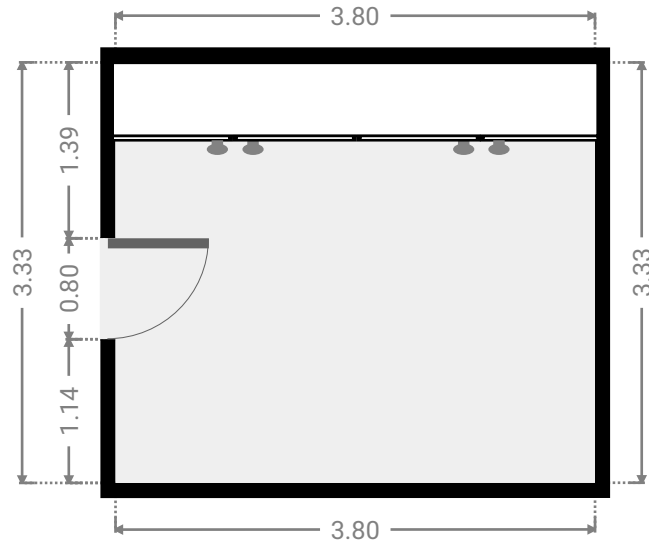
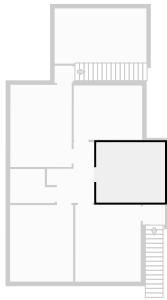

▼ Kitchen 1st Floor

WIDTH: 3.40 m • LENGTH: 4.56 m
AREA: 15.51 m² • PERIMETER: 15.92 m

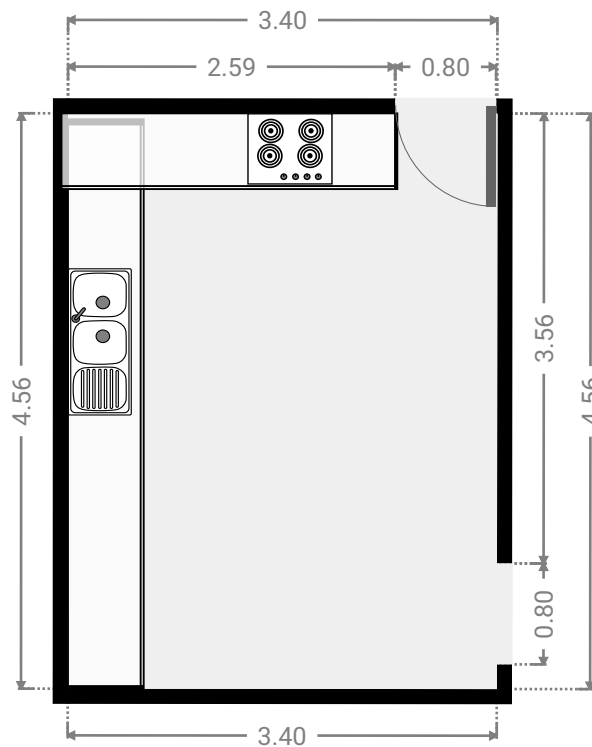
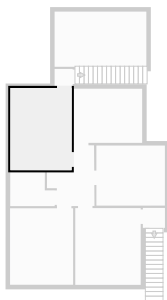

▼ **Bedroom**
1st Floor

WIDTH: 3.80 m • LENGTH: 3.00 m
AREA: 11.40 m² • PERIMETER: 13.60 m

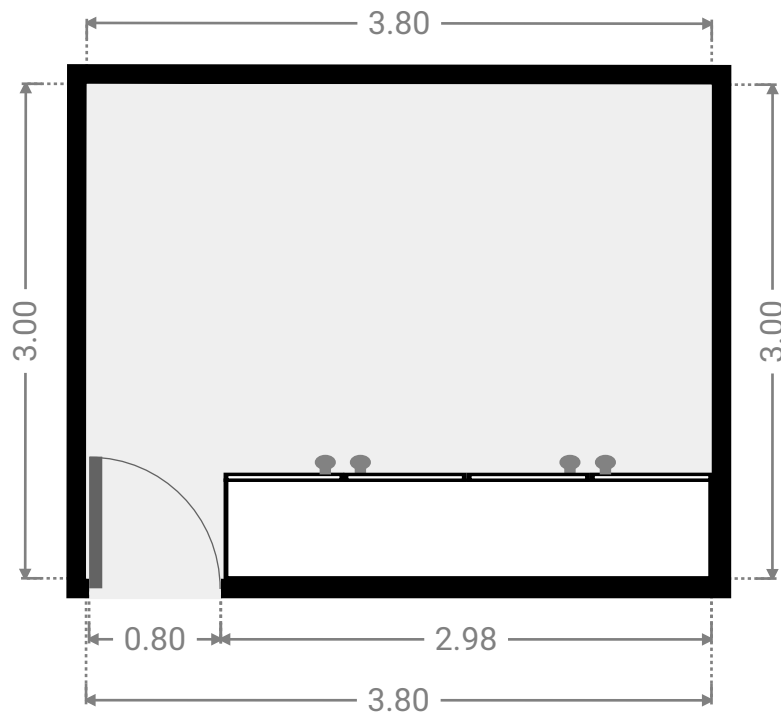
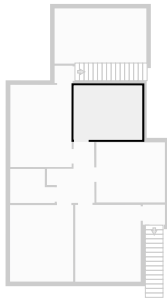

▼ **Hall**
1st Floor

WIDTH: 1.00 m • LENGTH: 0.96 m
AREA: 0.96 m² • PERIMETER: 3.92 m

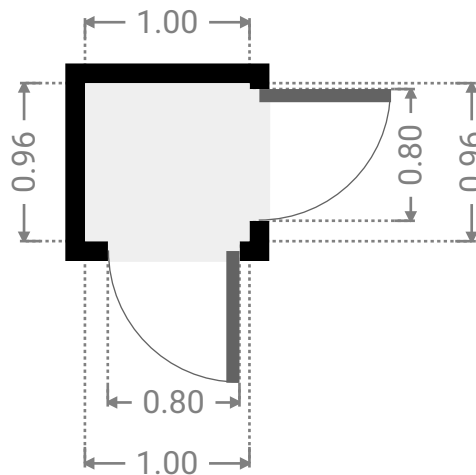
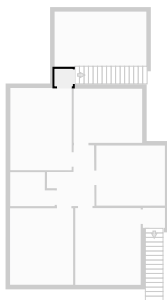

▼ Living Room 1st Floor

WIDTH: 5.09 m • LENGTH: 3.06 m
AREA: 15.58 m² • PERIMETER: 16.30 m

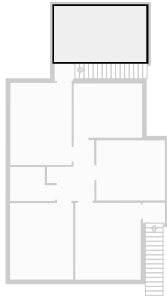

▼ Other 1st Floor

WIDTH: 1.22 m • LENGTH: 1.11 m
AREA: 1.35 m² • PERIMETER: 4.66 m

