

# 4 Cunningham Street

**SUBMITTED BY**

Ray White Rockhampton Casey  
stockers@cqoz.com

---

**CREATED ON**

2022-05-24

---

**Floors**

1

---

---

▼ Ground Floor



FLOORS: 1

▼ **Bathroom**  
Ground Floor

WIDTH: 2.14 m • LENGTH: 2.45 m  
AREA: 5.24 m<sup>2</sup> • PERIMETER: 9.18 m

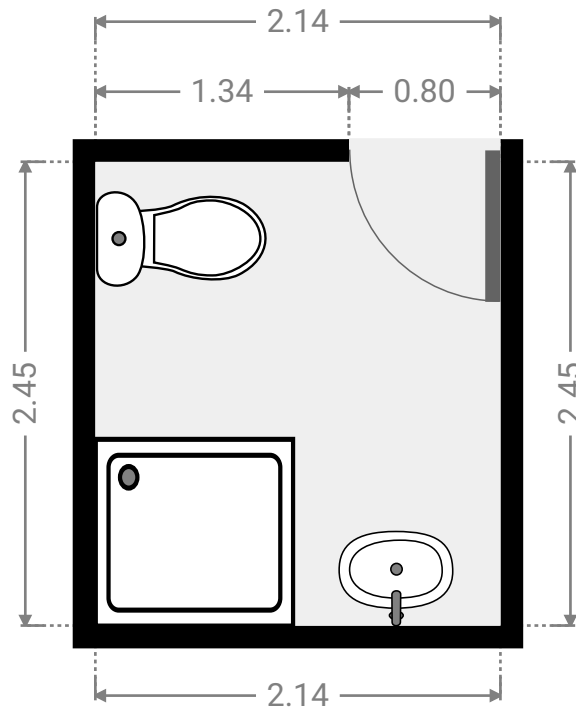
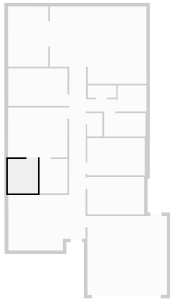

▼ **Bathroom**  
Ground Floor

WIDTH: 2.96 m • LENGTH: 1.67 m  
AREA: 4.94 m<sup>2</sup> • PERIMETER: 9.26 m

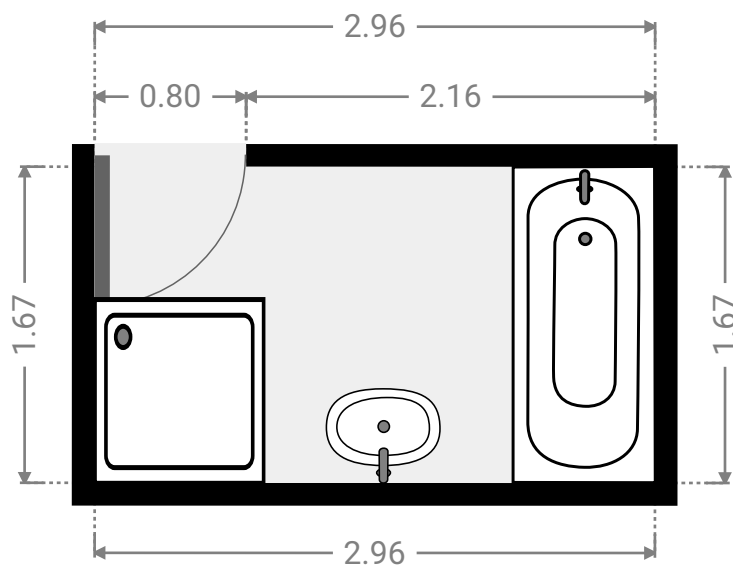
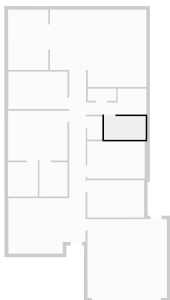

## ▼ Bedroom Ground Floor

WIDTH: 4.06 m • LENGTH: 2.67 m  
AREA: 10.84 m<sup>2</sup> • PERIMETER: 13.46 m

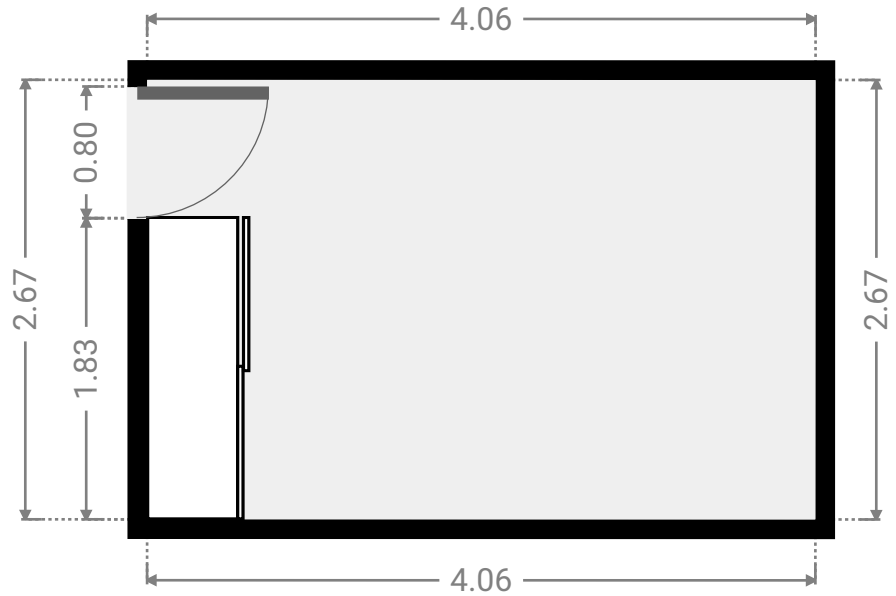
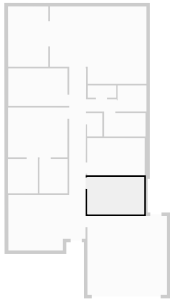

## ▼ Bedroom Ground Floor

WIDTH: 4.11 m • LENGTH: 2.66 m  
AREA: 10.94 m<sup>2</sup> • PERIMETER: 13.55 m

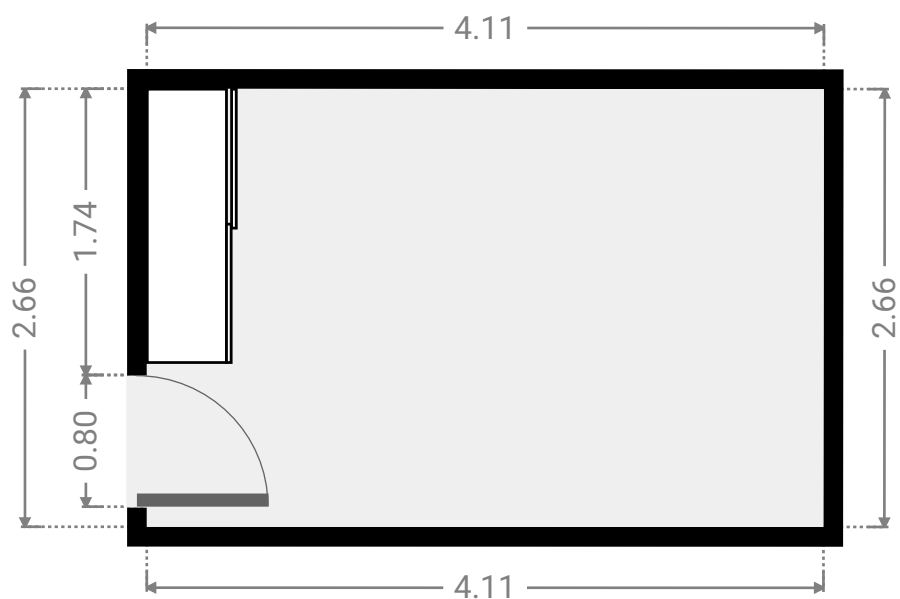
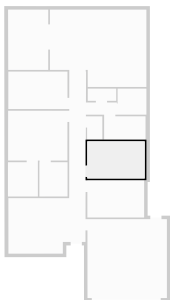

FLOORS: 1

## ▼ Bedroom Ground Floor

WIDTH: 4.23 m • LENGTH: 2.68 m  
AREA: 11.34 m<sup>2</sup> • PERIMETER: 13.82 m

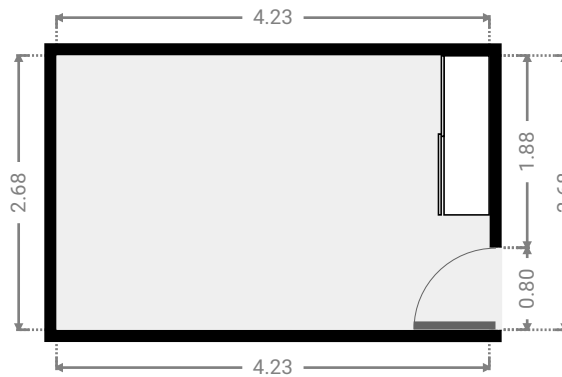
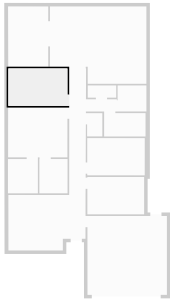

## ▼ Garage Ground Floor

WIDTH: 5.68 m • LENGTH: 5.64 m  
AREA: 32.04 m<sup>2</sup> • PERIMETER: 22.64 m

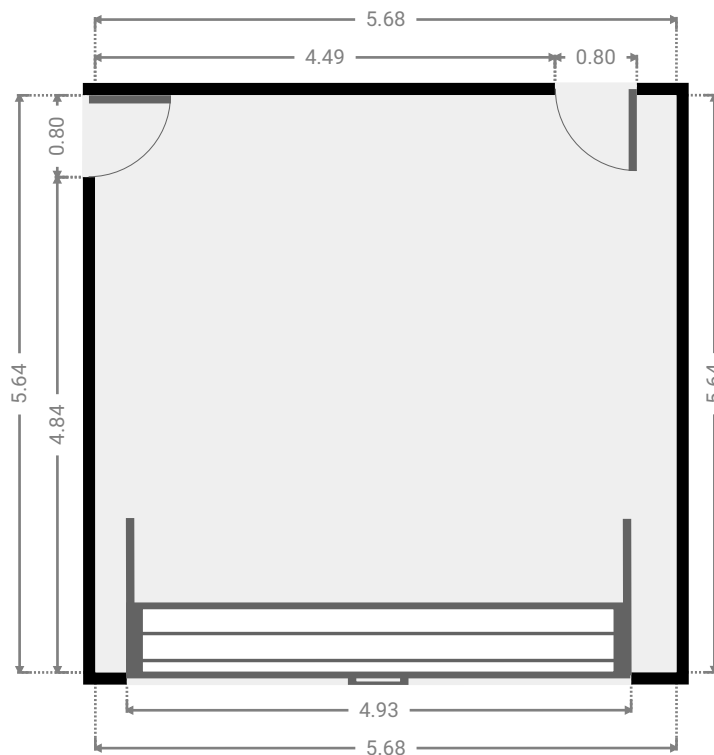
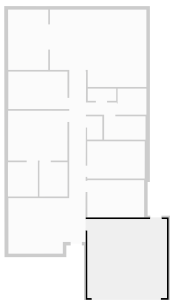

FLOORS: 1

## ▼ Hall Ground Floor

WIDTH: 1.20 m • LENGTH: 8.93 m  
AREA: 10.60 m<sup>2</sup> • PERIMETER: 20.24 m

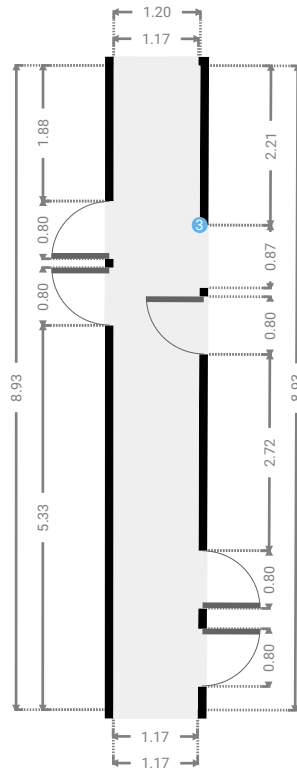

## ▼ Closet Ground Floor

WIDTH: 1.09 m • LENGTH: 1.66 m  
AREA: 1.81 m<sup>2</sup> • PERIMETER: 5.50 m

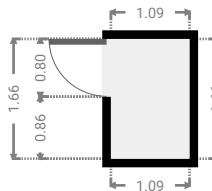

FLOORS: 1

## ▼ Hall Ground Floor

WIDTH: 2.16 m • LENGTH: 0.87 m  
AREA: 1.88 m<sup>2</sup> • PERIMETER: 6.06 m

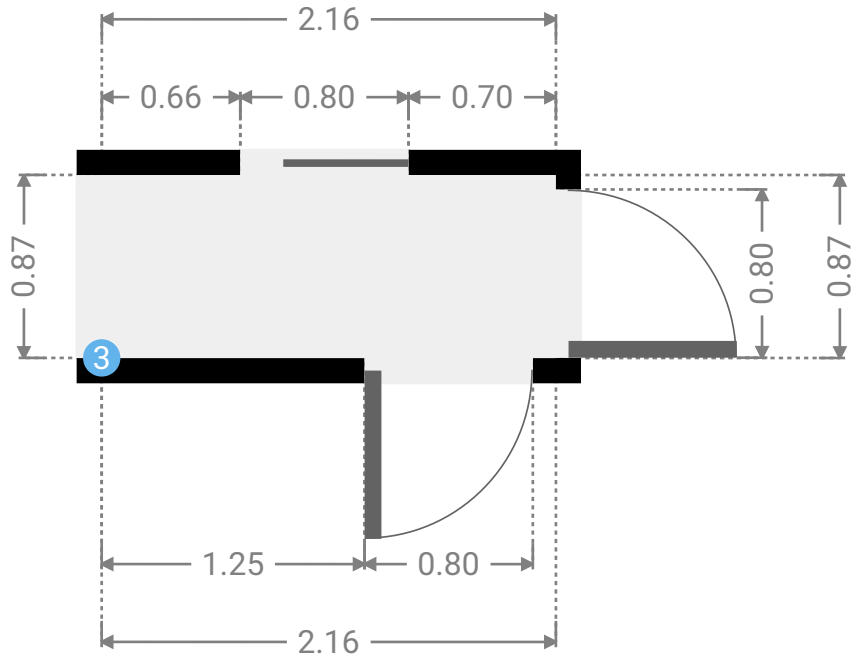
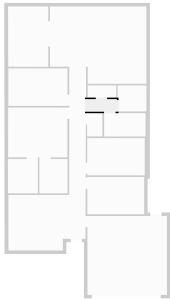

## ▼ Hall/Ground Floor

### 3 OPENING

Height  
0.00 m



## ▼ Kitchen Ground Floor

WIDTH: 6.90 m • LENGTH: 5.53 m  
AREA: 34.86 m<sup>2</sup> • PERIMETER: 24.86 m

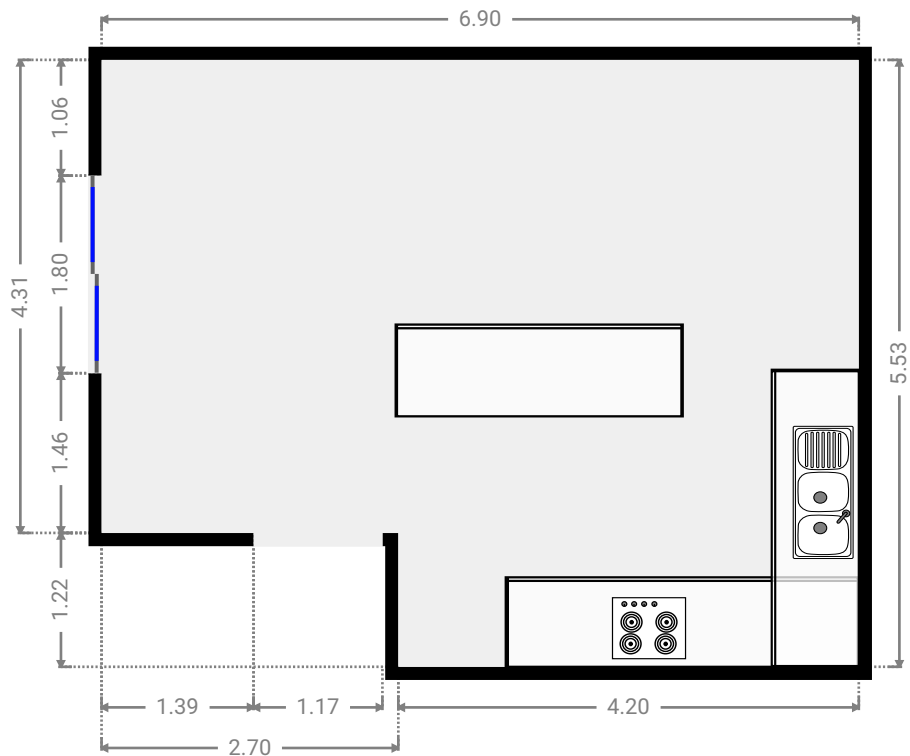

## ▼ Laundry Room Ground Floor

WIDTH: 2.06 m • LENGTH: 1.86 m  
AREA: 3.83 m<sup>2</sup> • PERIMETER: 7.84 m

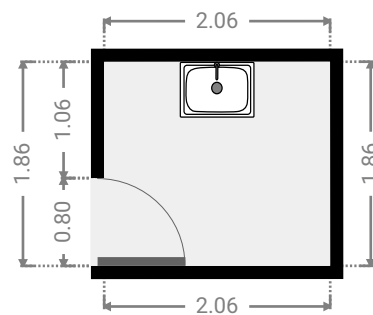
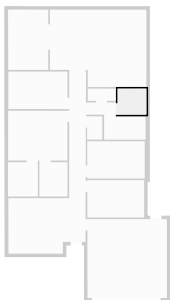



FLOORS: 1

## ▼ Living Room Ground Floor

WIDTH: 5.52 m • LENGTH: 3.97 m  
AREA: 20.53 m<sup>2</sup> • PERIMETER: 18.97 m

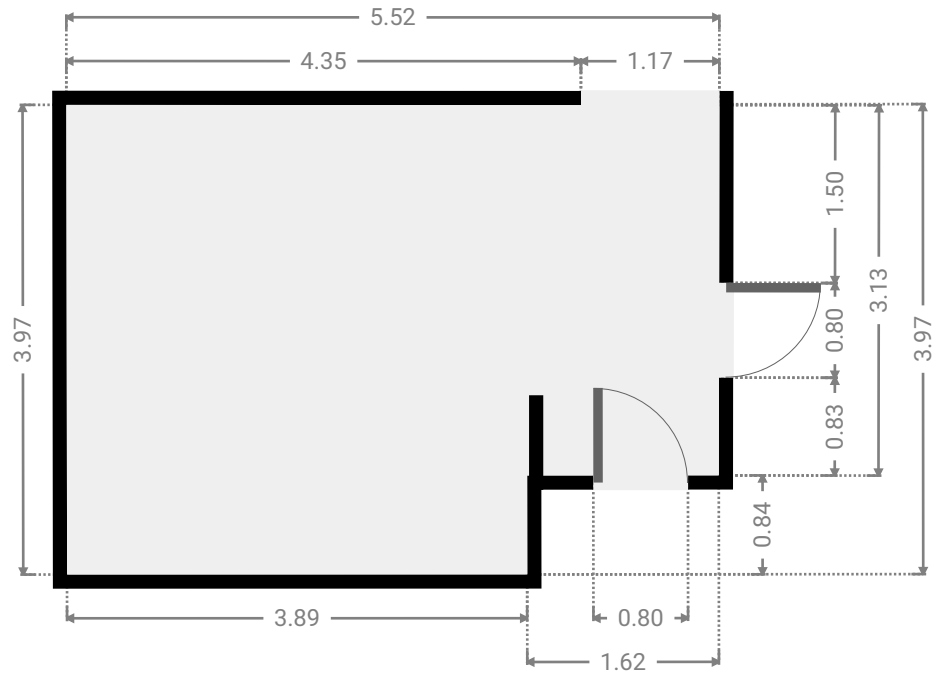
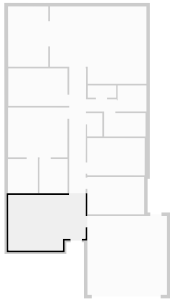

## ▼ Other Ground Floor

WIDTH: 2.88 m • LENGTH: 4.31 m  
AREA: 12.36 m<sup>2</sup> • PERIMETER: 14.36 m

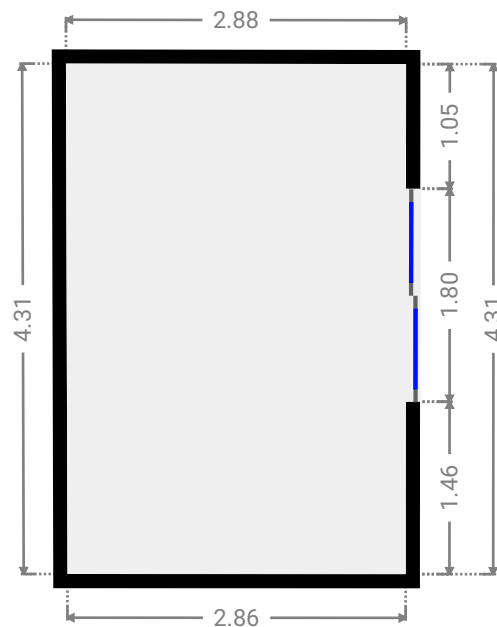
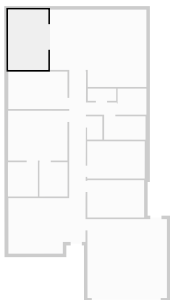

▼ **Primary Bedroom**  
Ground Floor

WIDTH: 4.24 m • LENGTH: 3.56 m  
AREA: 15.10 m<sup>2</sup> • PERIMETER: 15.60 m

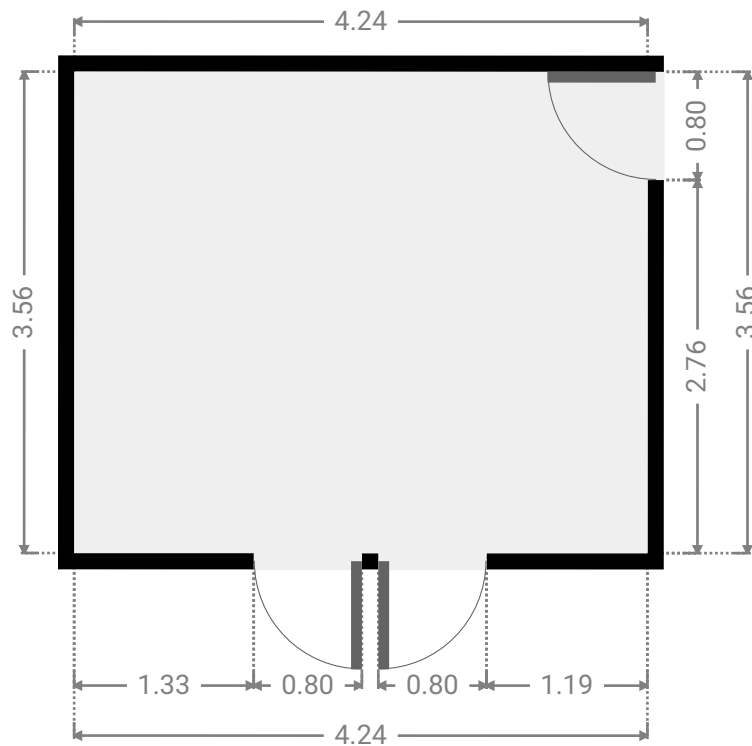
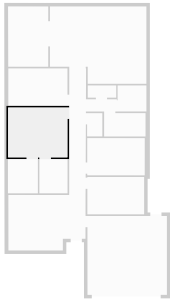

▼ **Closet**  
Ground Floor

WIDTH: 2.01 m • LENGTH: 2.45 m  
AREA: 4.93 m<sup>2</sup> • PERIMETER: 8.92 m

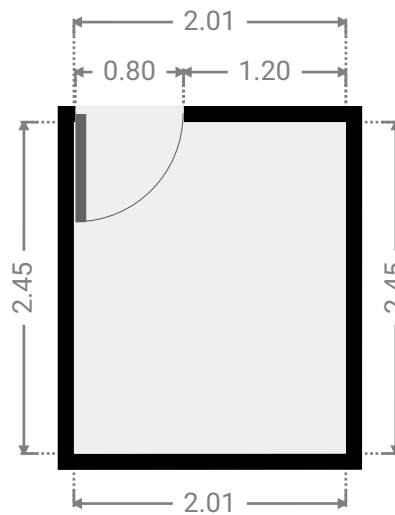
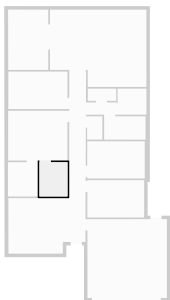

▼ Toilet  
Ground Floor

WIDTH: 2.04 m • LENGTH: 0.87 m  
AREA: 1.77 m<sup>2</sup> • PERIMETER: 5.82 m

