

4 Cunningham Court

SUBMITTED BY

Ray White Rockhampton Casey
stockers@cqoz.com

CREATED ON

2022-05-24

Floors

1

▼ Ground Floor



FLOORS: 1

▼ Bathroom
Ground Floor

WIDTH: 2.14 m • LENGTH: 2.45 m
AREA: 5.24 m² • PERIMETER: 9.18 m

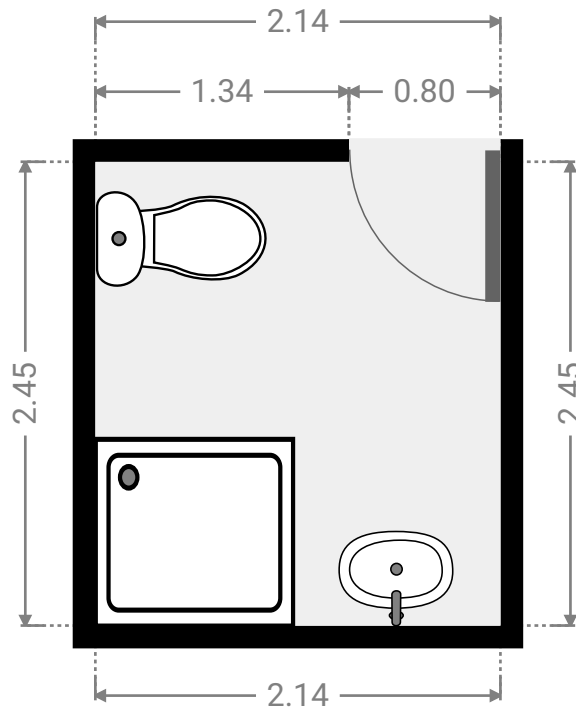
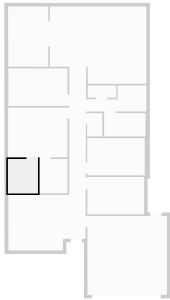

▼ Bathroom
Ground Floor

WIDTH: 2.96 m • LENGTH: 1.67 m
AREA: 4.94 m² • PERIMETER: 9.26 m

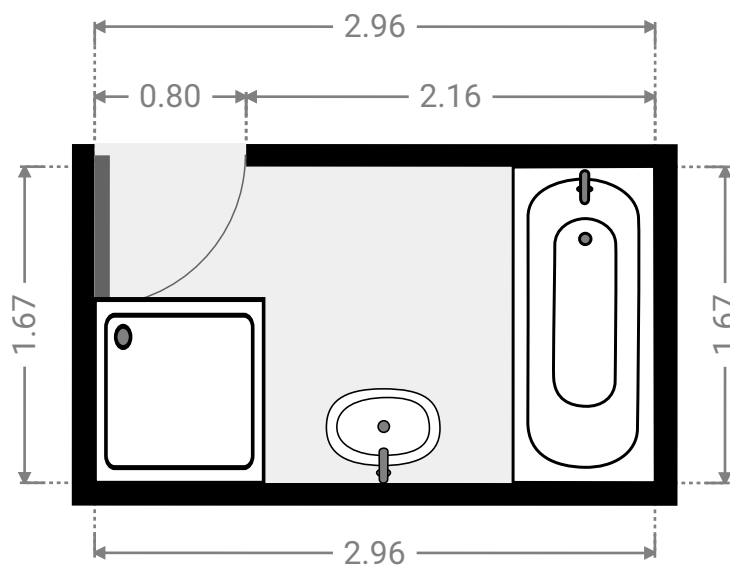
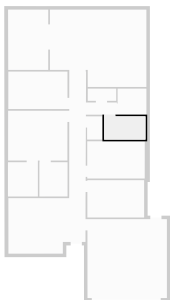

▼ Bedroom Ground Floor

WIDTH: 4.06 m • LENGTH: 2.67 m
AREA: 10.84 m² • PERIMETER: 13.46 m

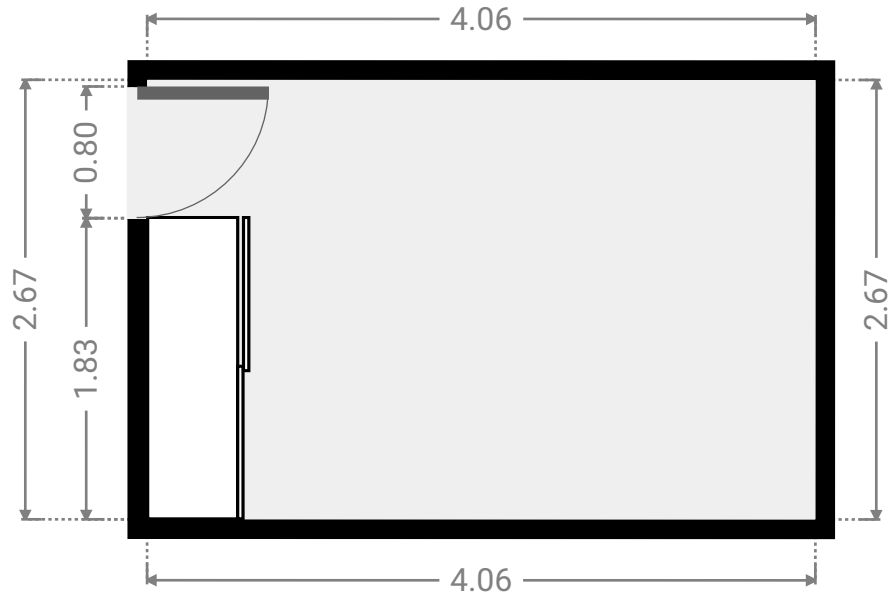
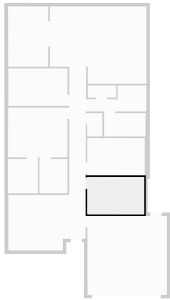

▼ Bedroom Ground Floor

WIDTH: 4.11 m • LENGTH: 2.66 m
AREA: 10.94 m² • PERIMETER: 13.55 m

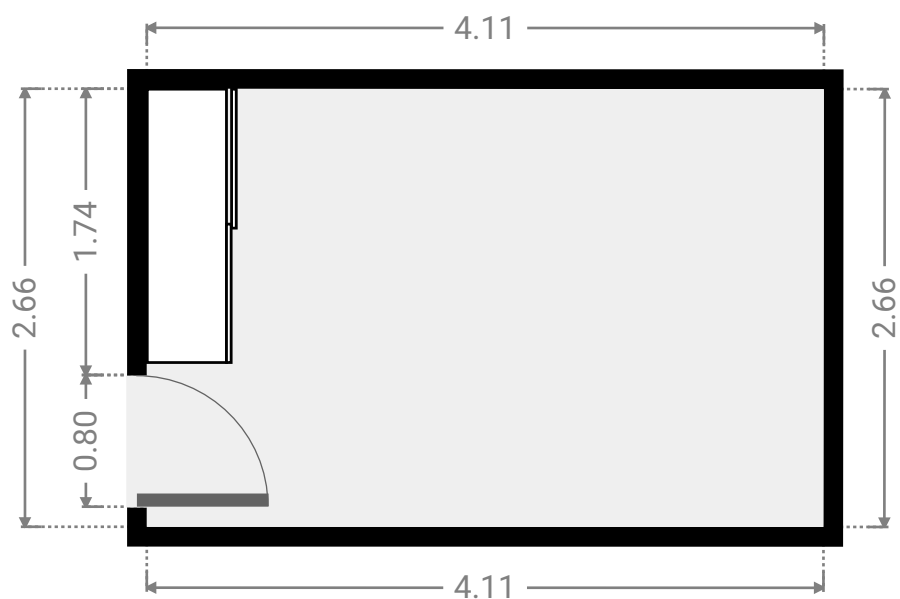
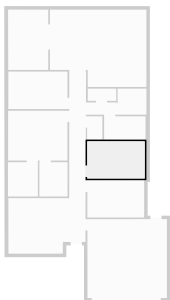

FLOORS: 1

▼ Bedroom
Ground Floor

WIDTH: 4.23 m • LENGTH: 2.68 m
AREA: 11.34 m² • PERIMETER: 13.82 m

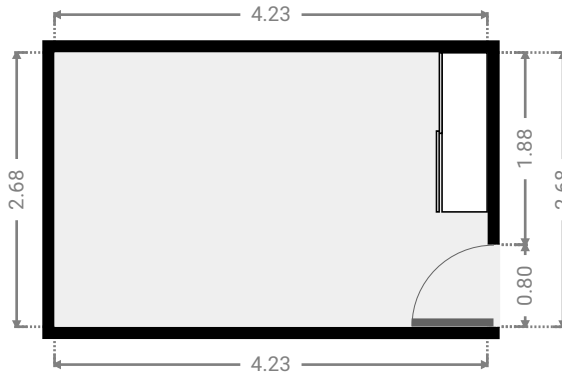
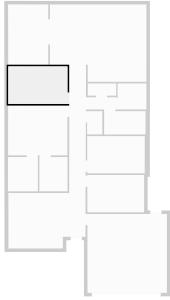

▼ Garage
Ground Floor

WIDTH: 5.68 m • LENGTH: 5.64 m
AREA: 32.04 m² • PERIMETER: 22.64 m

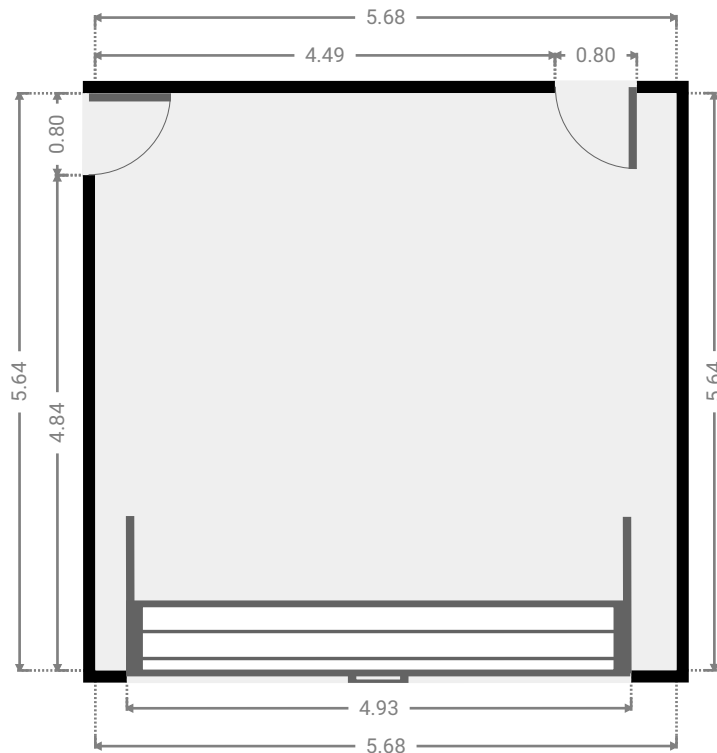
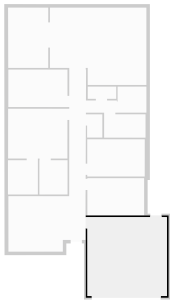

FLOORS: 1

▼ Hall Ground Floor

WIDTH: 1.20 m • LENGTH: 8.93 m
AREA: 10.60 m² • PERIMETER: 20.24 m

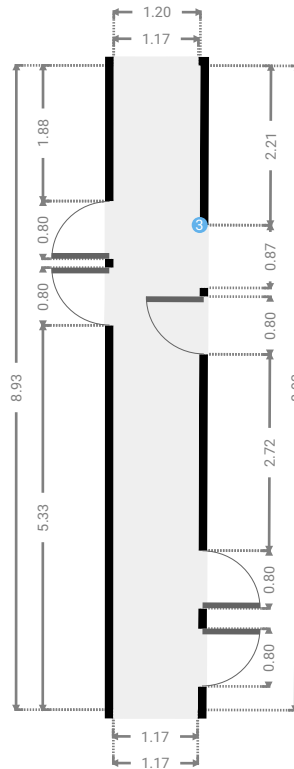

▼ Closet Ground Floor

WIDTH: 1.09 m • LENGTH: 1.66 m
AREA: 1.81 m² • PERIMETER: 5.50 m

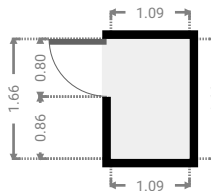
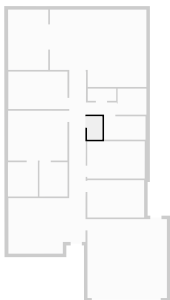

FLOORS: 1

▼ Hall Ground Floor

WIDTH: 2.16 m • LENGTH: 0.87 m
AREA: 1.88 m² • PERIMETER: 6.06 m

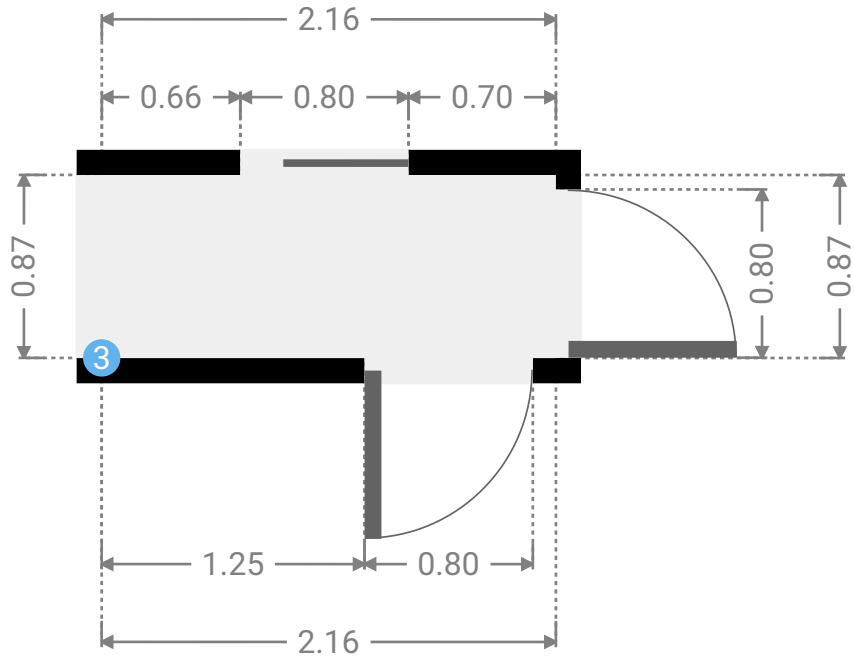
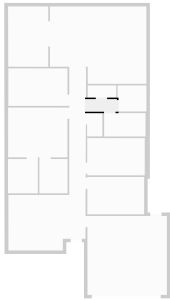

▼ Hall/Ground Floor

3 OPENING

Height
0.00 m



▼ Kitchen Ground Floor

WIDTH: 6.90 m • LENGTH: 5.53 m
AREA: 34.86 m² • PERIMETER: 24.86 m

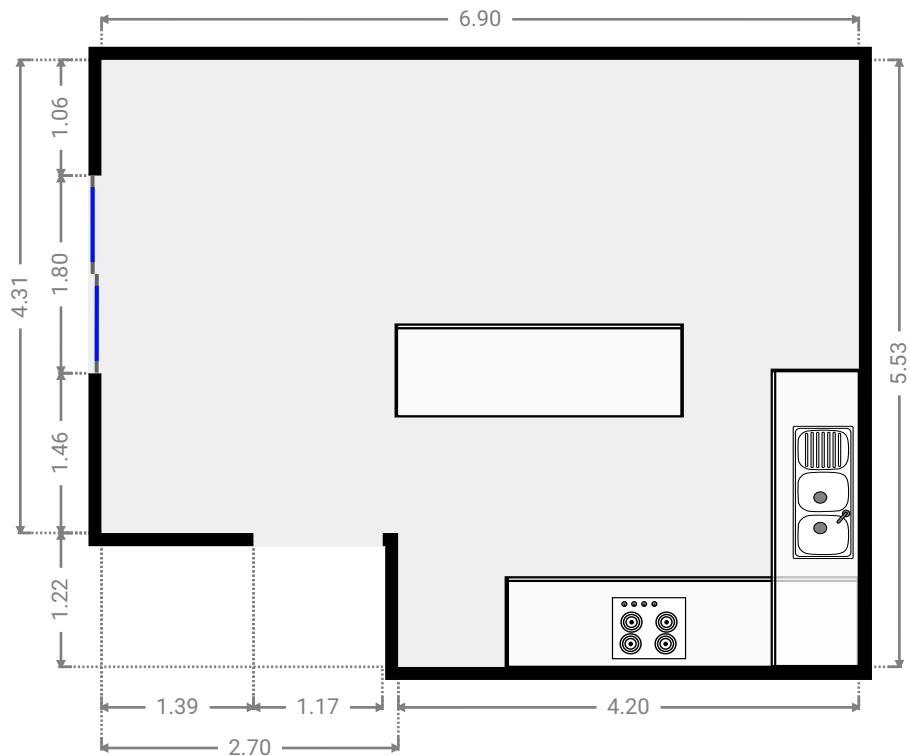
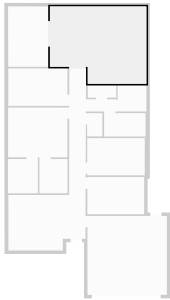

▼ Laundry Room Ground Floor

WIDTH: 2.06 m • LENGTH: 1.86 m
AREA: 3.83 m² • PERIMETER: 7.84 m

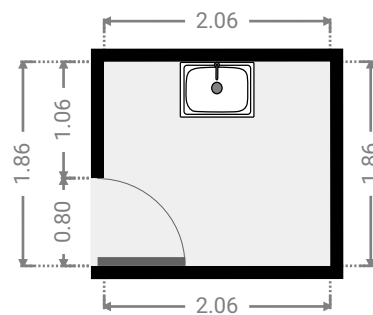
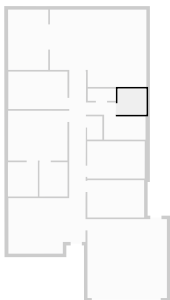

FLOORS: 1

▼ Living Room
Ground Floor

WIDTH: 5.52 m • LENGTH: 3.97 m
AREA: 20.53 m² • PERIMETER: 18.97 m

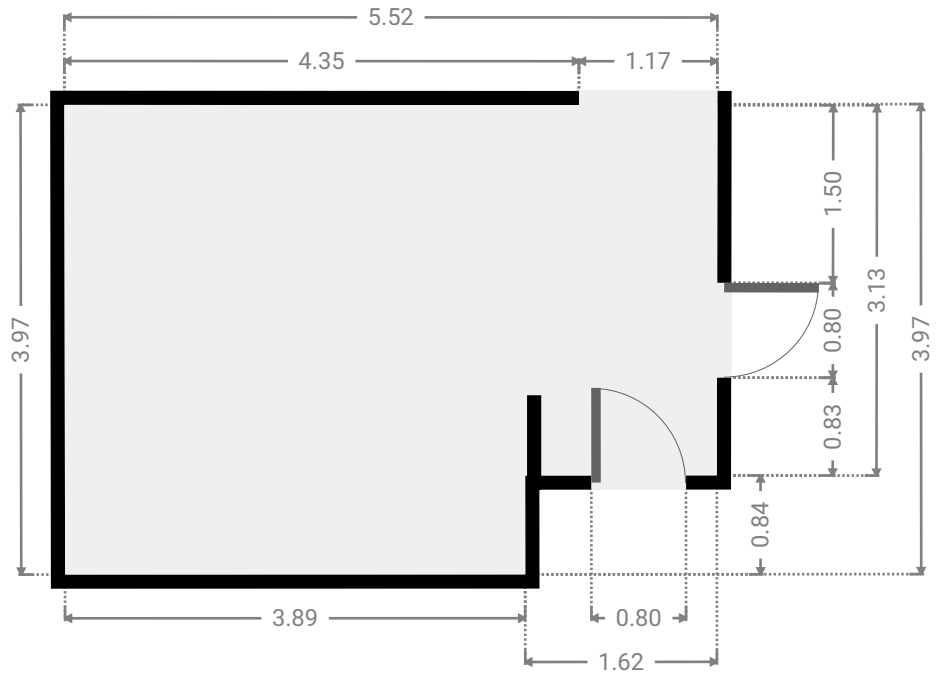
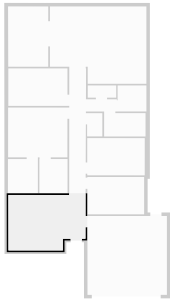

▼ Other
Ground Floor

WIDTH: 2.88 m • LENGTH: 4.31 m
AREA: 12.36 m² • PERIMETER: 14.36 m

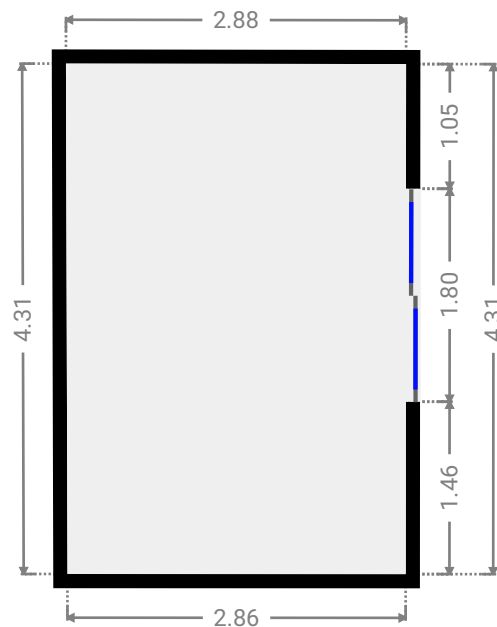
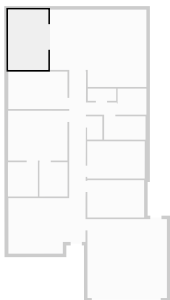

FLOORS: 1

▼ Primary Bedroom Ground Floor

WIDTH: 4.24 m • LENGTH: 3.56 m
AREA: 15.10 m² • PERIMETER: 15.60 m

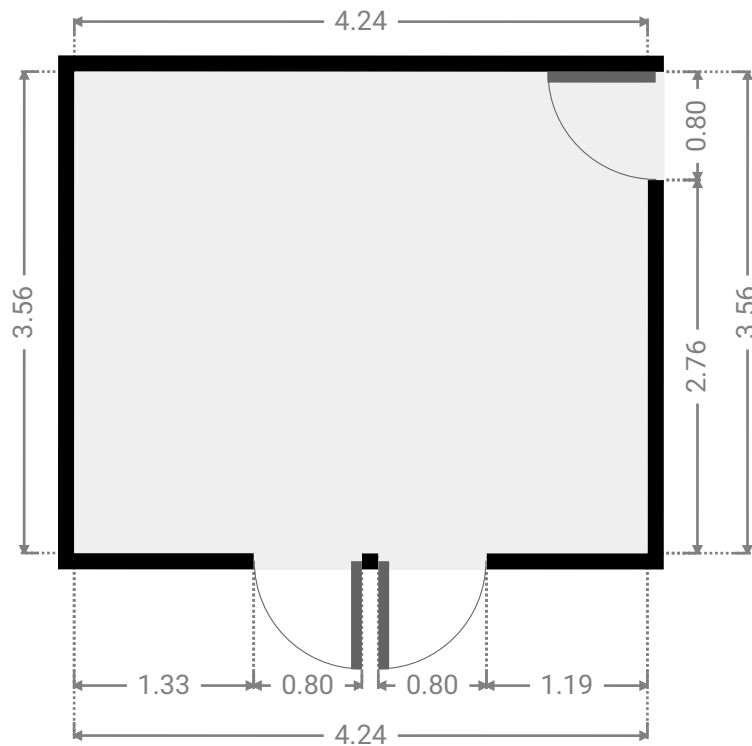
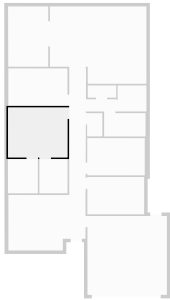

▼ Closet Ground Floor

WIDTH: 2.01 m • LENGTH: 2.45 m
AREA: 4.93 m² • PERIMETER: 8.92 m

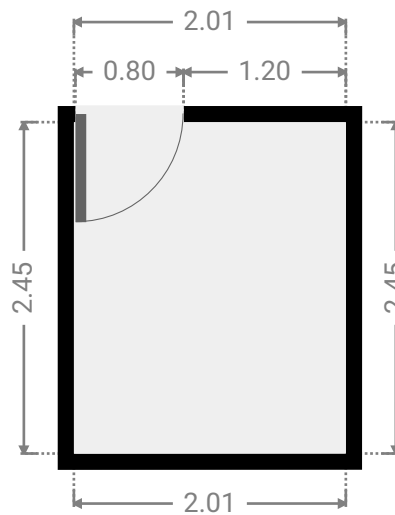
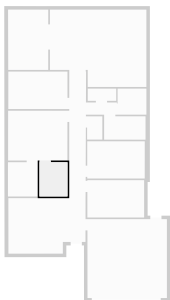

▼ Toilet
Ground Floor

WIDTH: 2.04 m • LENGTH: 0.87 m
AREA: 1.77 m² • PERIMETER: 5.82 m

