

4/35 Wentworth Terrace

SUBMITTED BY

Ray White Rockhampton Casey
stockers@cqoz.com

CREATED ON

2022-11-09

Floors

2

▼ Basement • Level 1

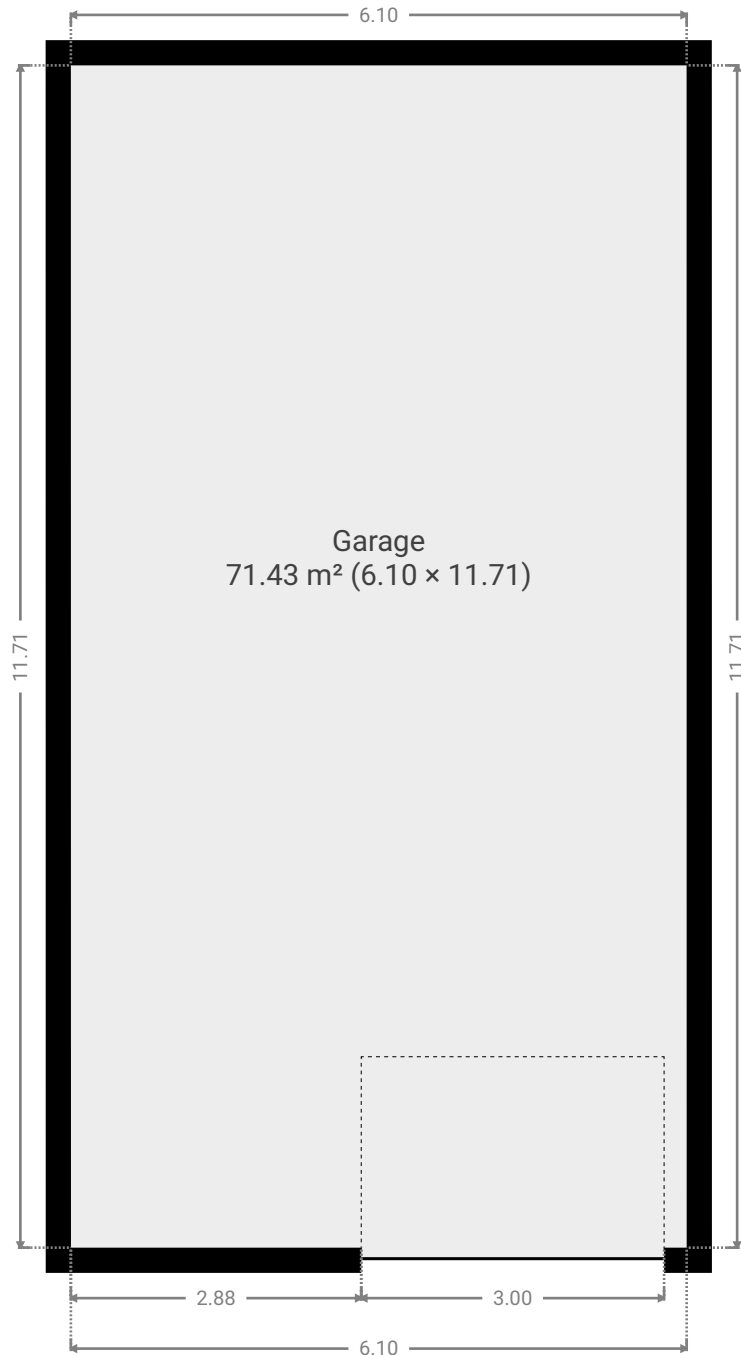

▼ **Garage**
Basement • Level 1

WIDTH: 11.71 m • LENGTH: 6.10 m
AREA: 71.43 m² • PERIMETER: 35.62 m



▼ Ground Floor

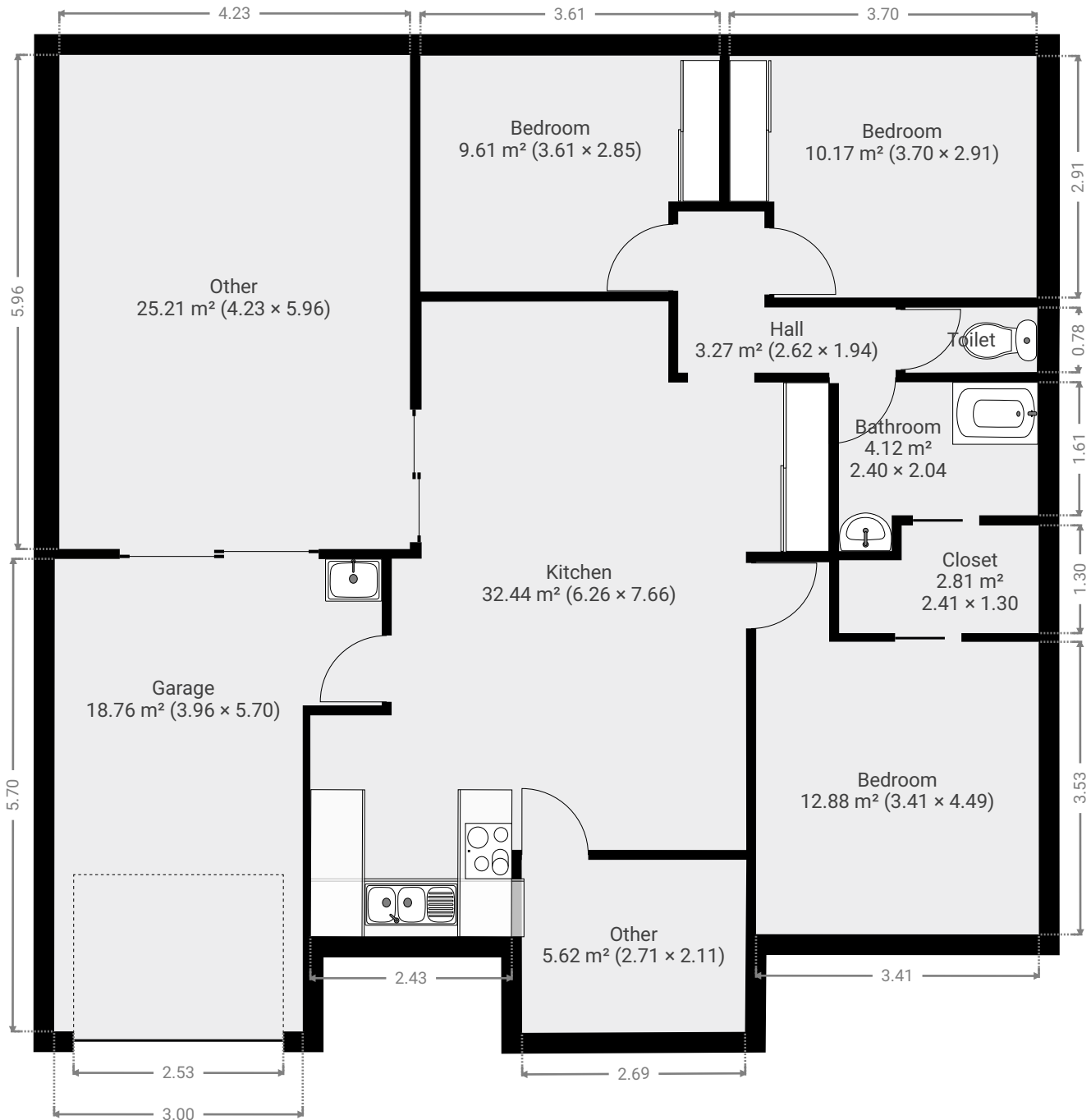

FLOORS: 2

▼ **Bathroom**
Ground Floor

WIDTH: 2.40 m • LENGTH: 2.04 m
AREA: 4.12 m² • PERIMETER: 8.87 m

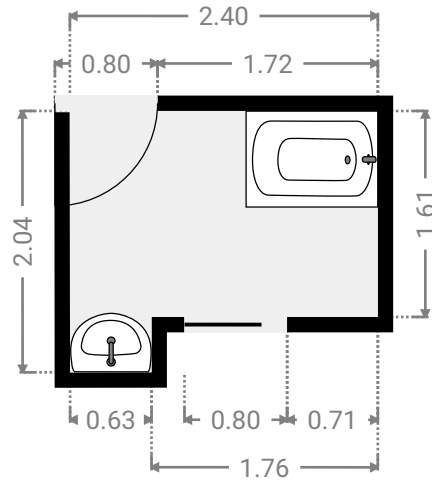
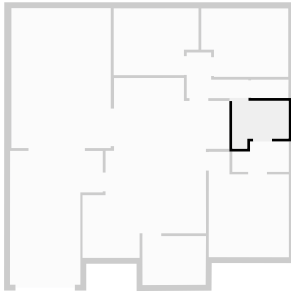

▼ **Bedroom**
Ground Floor

WIDTH: 3.41 m • LENGTH: 4.49 m
AREA: 12.88 m² • PERIMETER: 15.80 m

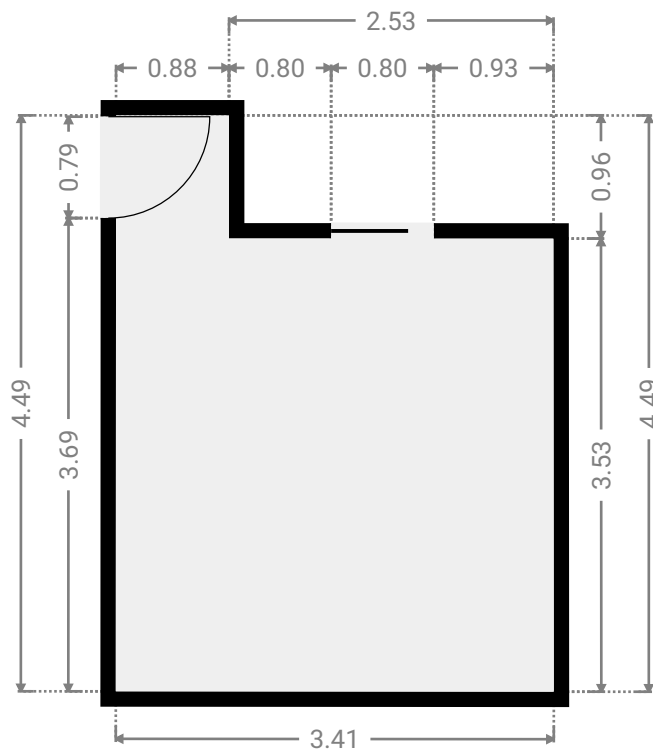
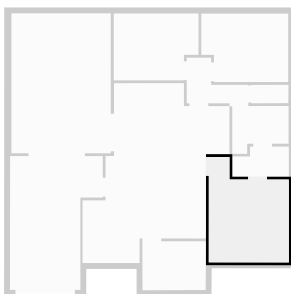

FLOORS: 2

▼ **Bedroom**
Ground Floor

WIDTH: 3.61 m • LENGTH: 2.85 m
AREA: 9.61 m² • PERIMETER: 12.92 m

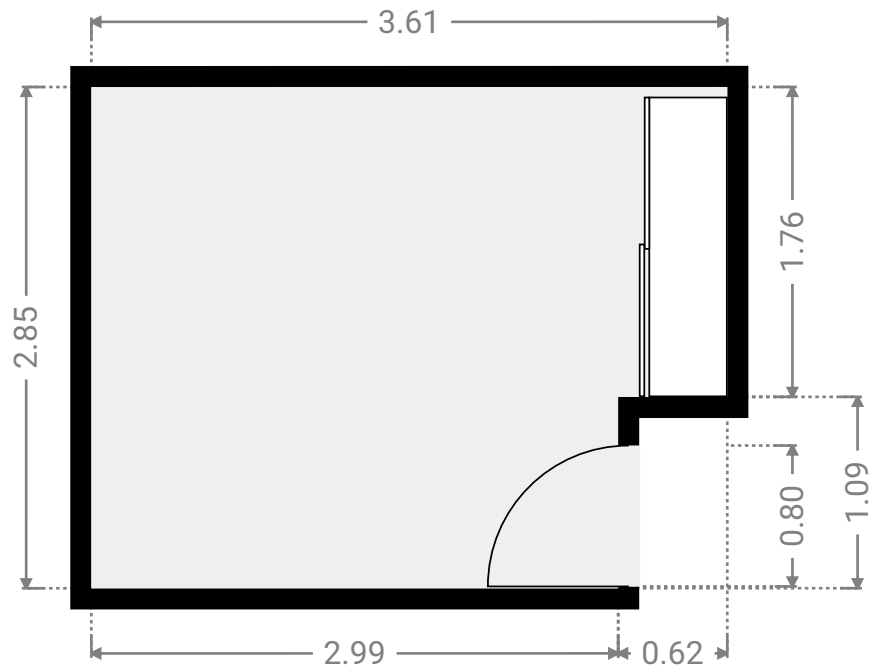
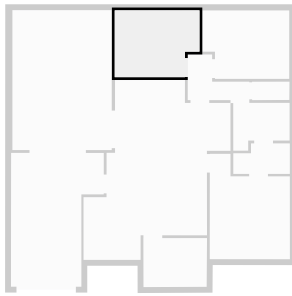

▼ **Bedroom**
Ground Floor

WIDTH: 3.70 m • LENGTH: 2.91 m
AREA: 10.17 m² • PERIMETER: 13.24 m

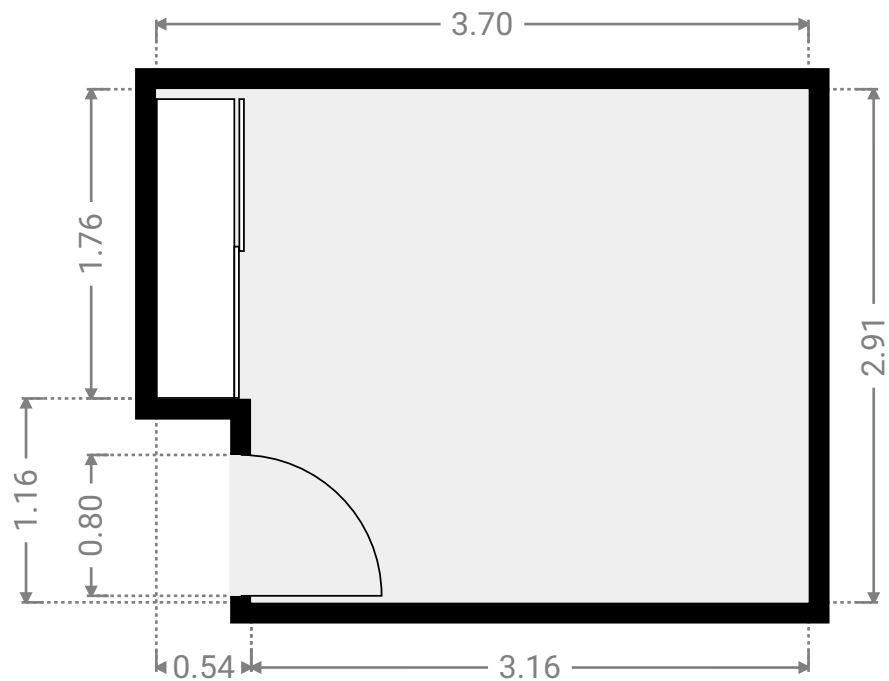
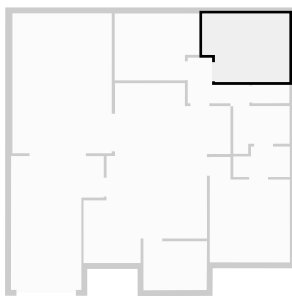

FLOORS: 2

▼ **Closet**
Ground Floor

WIDTH: 2.41 m • LENGTH: 1.30 m
AREA: 2.81 m² • PERIMETER: 7.42 m

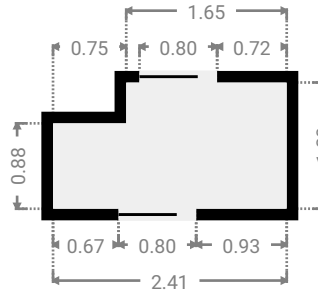
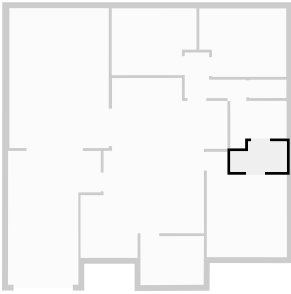

▼ **Garage**
Ground Floor

WIDTH: 3.96 m • LENGTH: 5.70 m
AREA: 18.76 m² • PERIMETER: 19.30 m

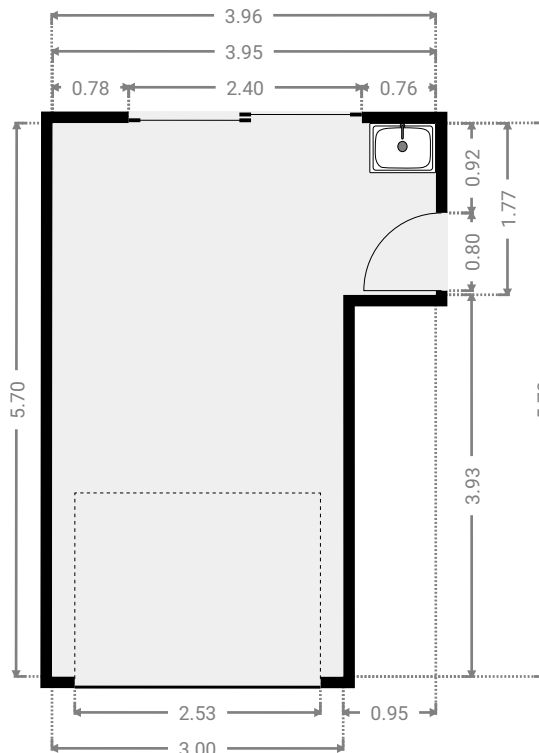
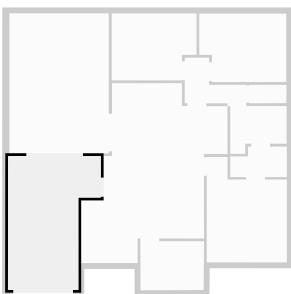

FLOORS: 2

▼ **Hall**
Ground Floor

WIDTH: 2.62 m • LENGTH: 1.94 m
AREA: 3.27 m² • PERIMETER: 9.13 m

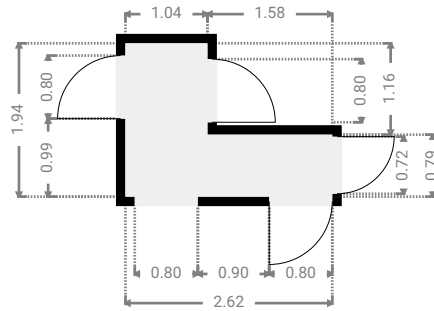
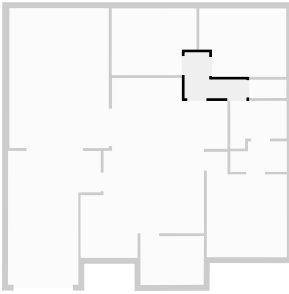

▼ **Kitchen**
Ground Floor

WIDTH: 6.26 m • LENGTH: 7.66 m
AREA: 32.44 m² • PERIMETER: 27.85 m

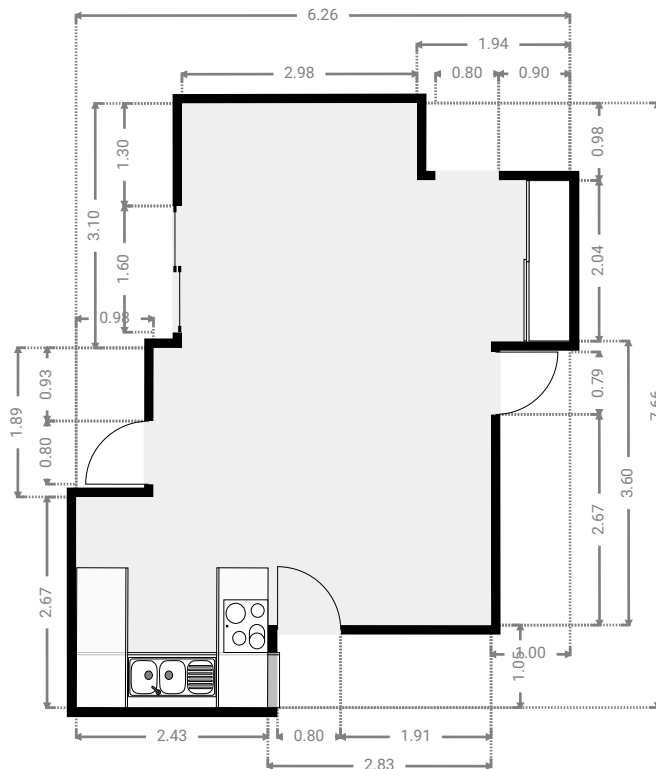
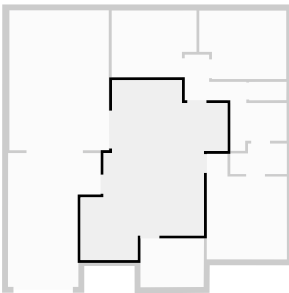

THIS FLOORPLAN IS PROVIDED WITHOUT WARRANTY OF ANY KIND. SENSOPIA DISCLAIMS ANY WARRANTY INCLUDING, WITHOUT LIMITATION, SATISFACTORY QUALITY OR ACCURACY OF DIMENSIONS.

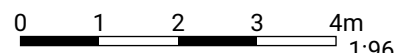

▼ Other
Ground Floor

WIDTH: 4.23 m • LENGTH: 5.96 m
AREA: 25.21 m² • PERIMETER: 20.38 m

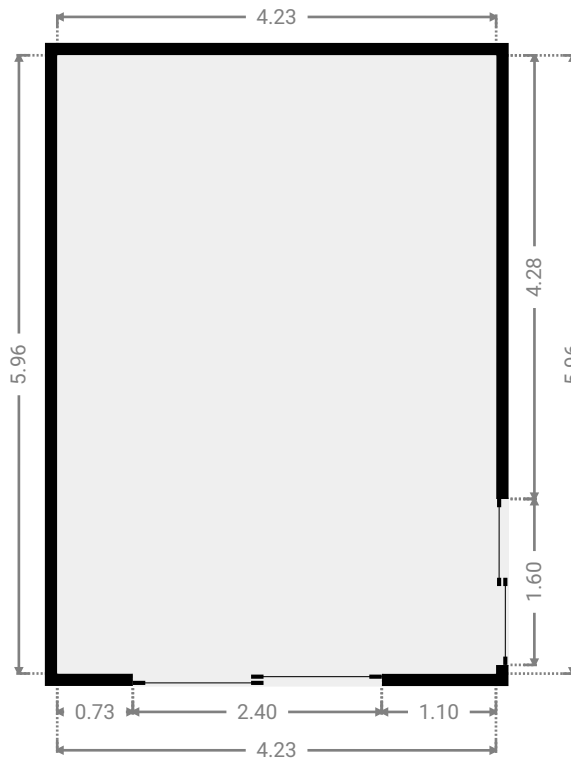
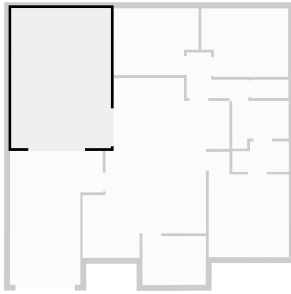

▼ Other
Ground Floor

WIDTH: 2.71 m • LENGTH: 2.11 m
AREA: 5.62 m² • PERIMETER: 9.57 m

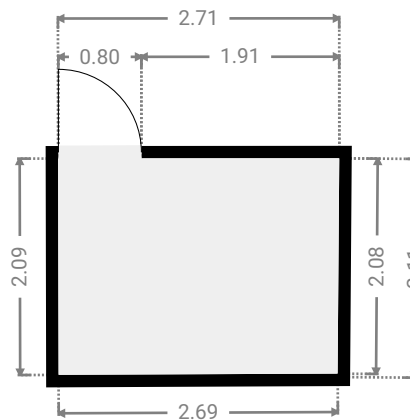
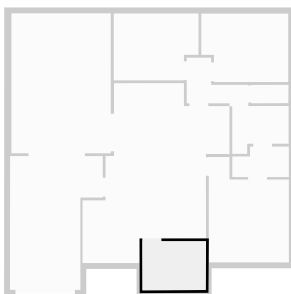

FLOORS: 2

▼ Toilet
Ground Floor

WIDTH: 1.59 m • LENGTH: 0.78 m
AREA: 1.24 m² • PERIMETER: 4.74 m

