

397 Farm Street

Created on
2021-03-31

Floors
1

▼ Ground Floor

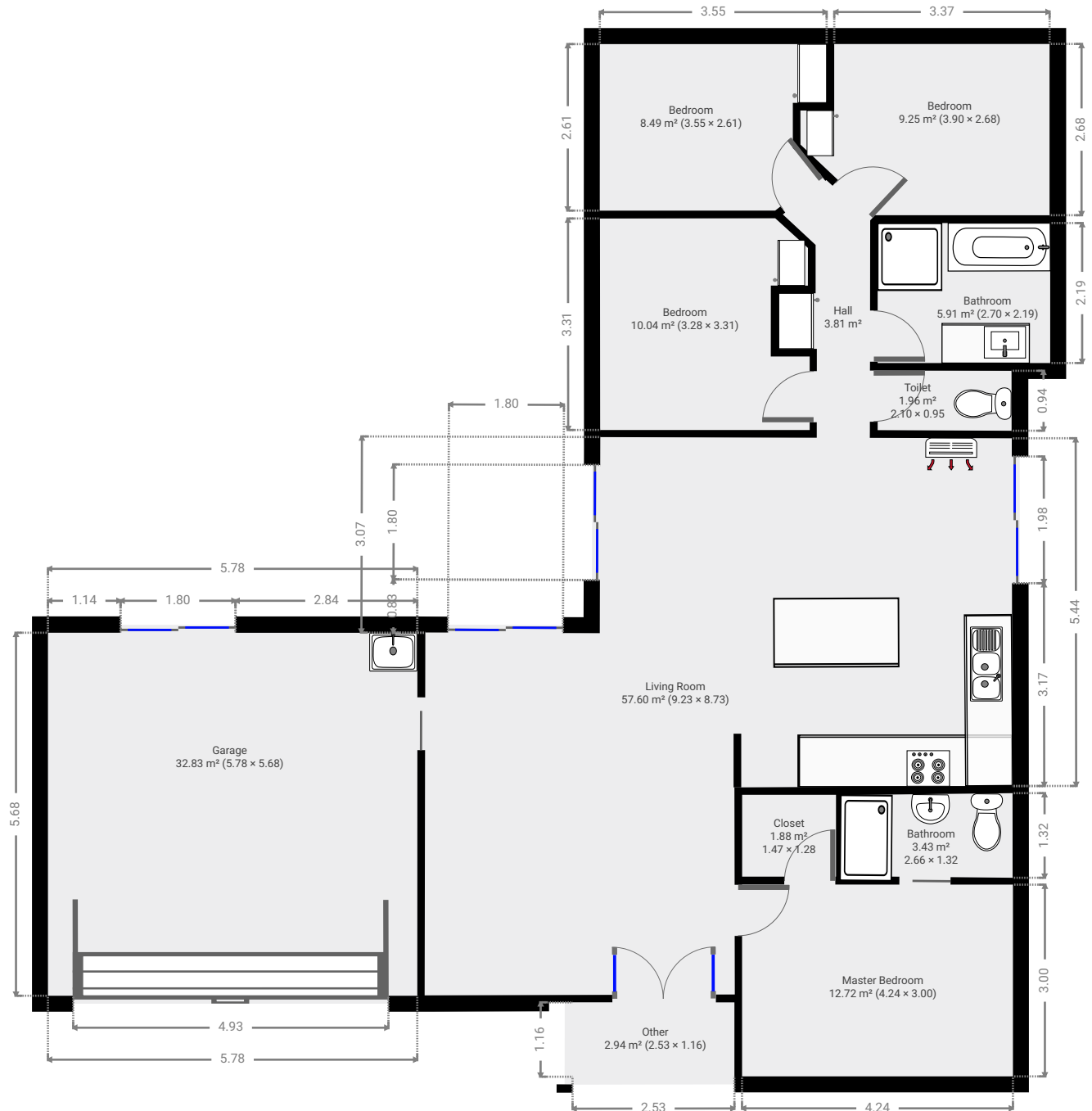

▼ Living Room
Ground Floor

WIDTH: 9.23 m • LENGTH: 8.73 m
AREA: 57.60 m² • PERIMETER: 35.80 m

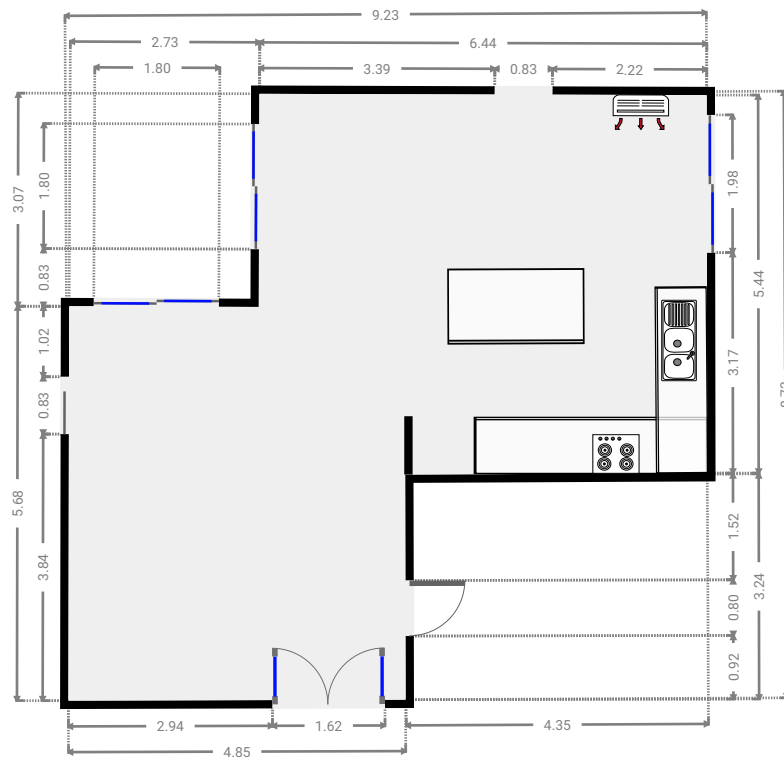
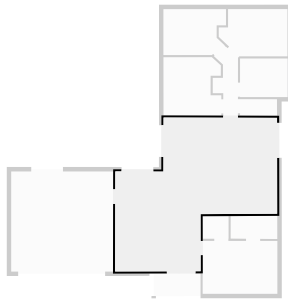

▼ Garage
Ground Floor

WIDTH: 5.78 m • LENGTH: 5.68 m
AREA: 32.83 m² • PERIMETER: 22.92 m

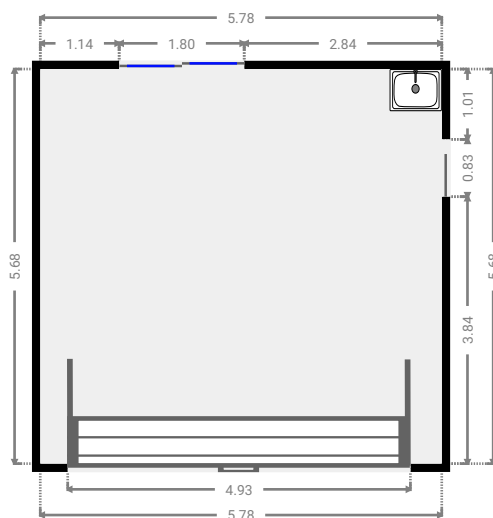
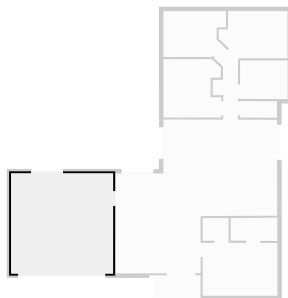

▼ **Hall**
Ground Floor

WIDTH: 1.43 m • LENGTH: 3.92 m
AREA: 3.81 m² • PERIMETER: 10.70 m

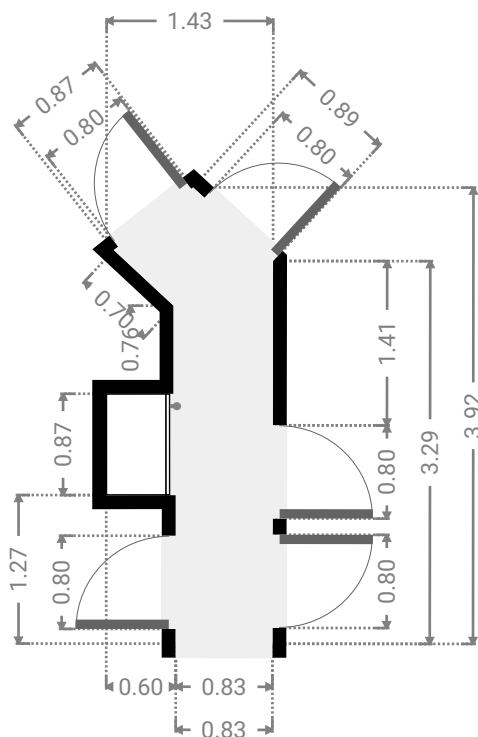
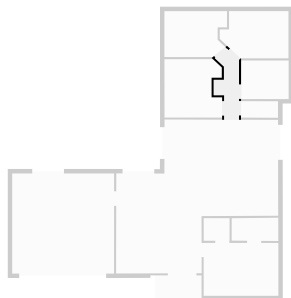

▼ **Bedroom**
Ground Floor

WIDTH: 3.28 m • LENGTH: 3.31 m
AREA: 10.04 m² • PERIMETER: 14.06 m

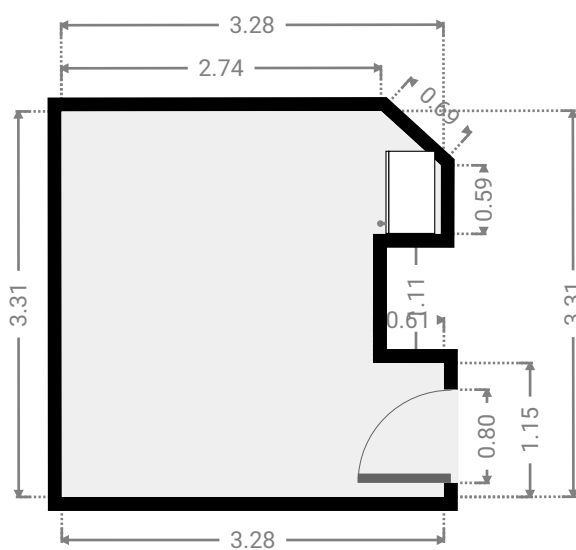
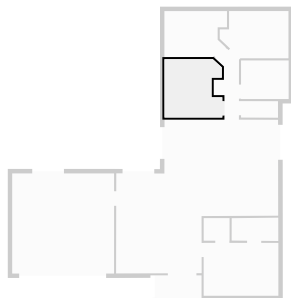

▼ **Toilet**
Ground Floor

WIDTH: 2.10 m • LENGTH: 0.95 m
AREA: 1.96 m² • PERIMETER: 6.06 m

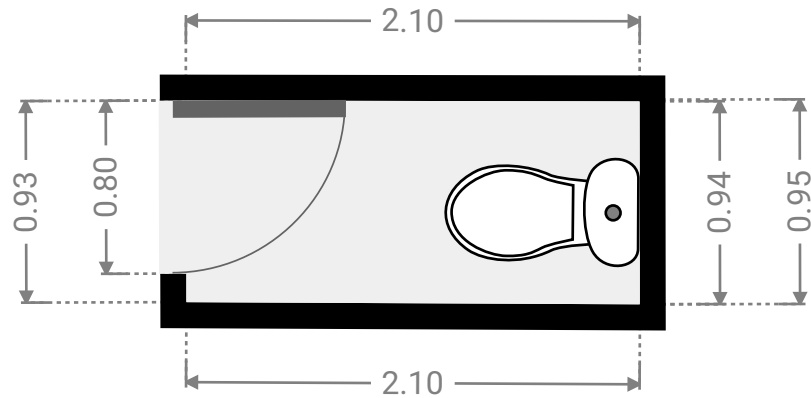
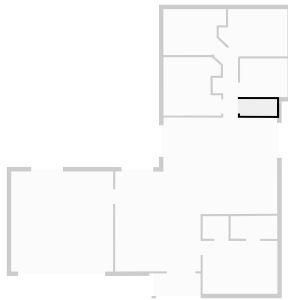

▼ **Bathroom**
Ground Floor

WIDTH: 2.70 m • LENGTH: 2.19 m
AREA: 5.91 m² • PERIMETER: 9.78 m

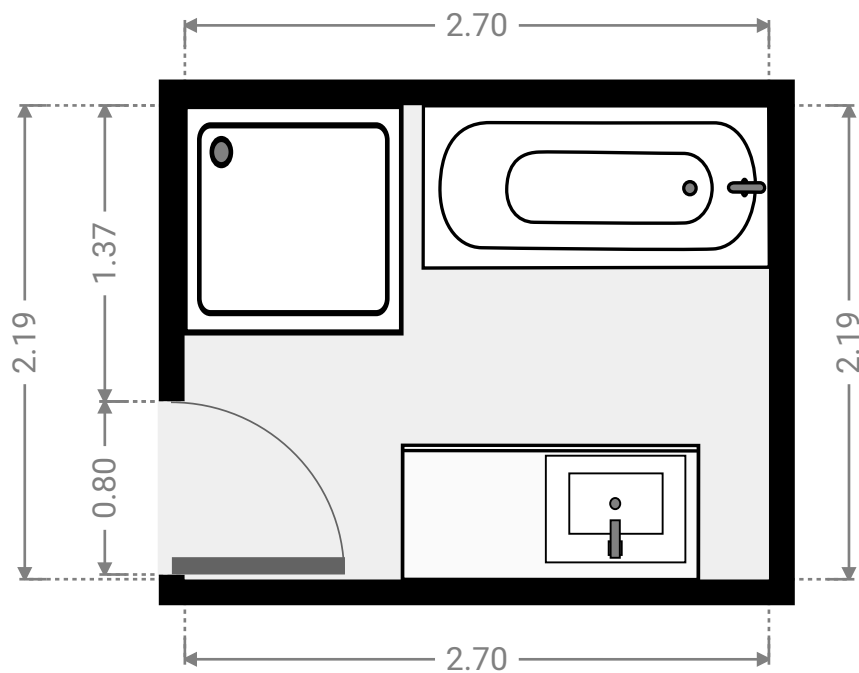
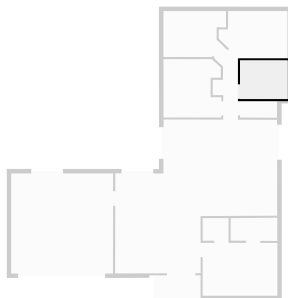

▼ **Bedroom**
Ground Floor

WIDTH: 3.90 m • LENGTH: 2.68 m
AREA: 9.25 m² • PERIMETER: 12.49 m

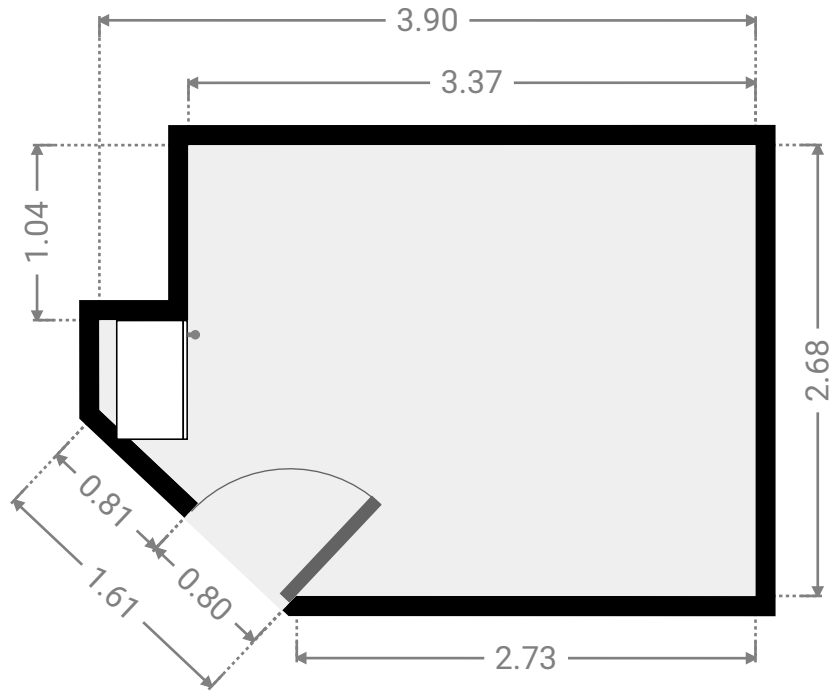
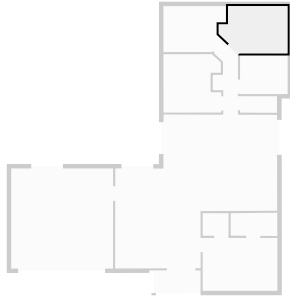

▼ **Bedroom**
Ground Floor

WIDTH: 3.55 m • LENGTH: 2.61 m
AREA: 8.49 m² • PERIMETER: 12.57 m

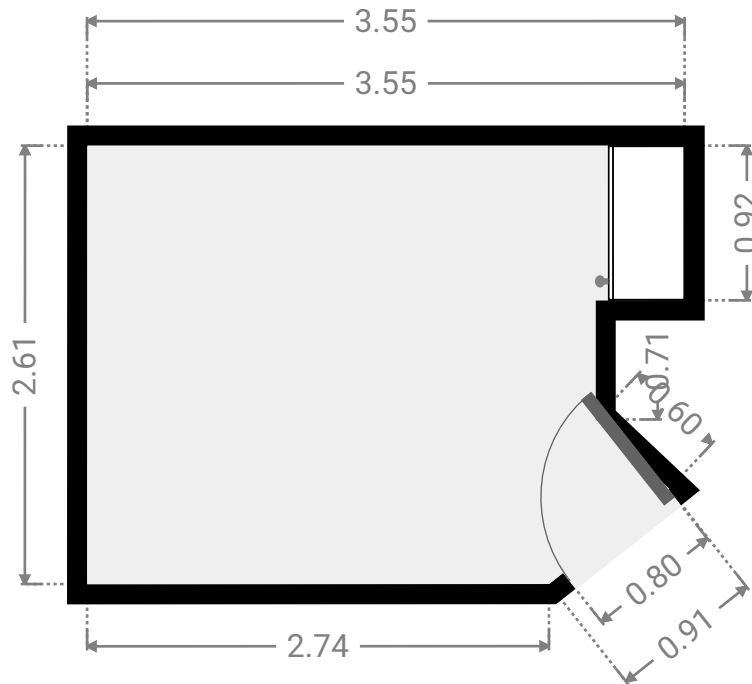
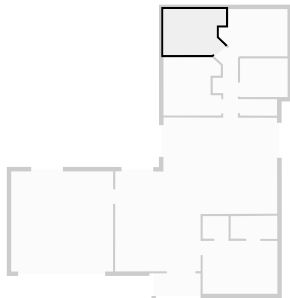

▼ **Master Bedroom**
Ground Floor

WIDTH: 4.24 m • LENGTH: 3.00 m
AREA: 12.72 m² • PERIMETER: 14.48 m

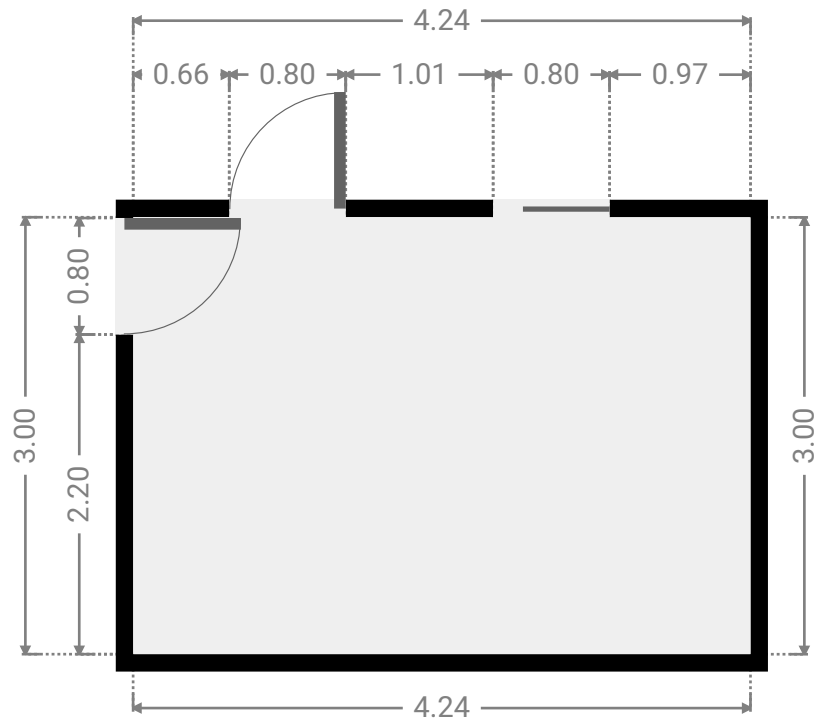
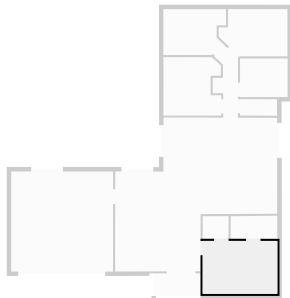

▼ **Closet**
Ground Floor

WIDTH: 1.47 m • LENGTH: 1.28 m
AREA: 1.88 m² • PERIMETER: 5.50 m

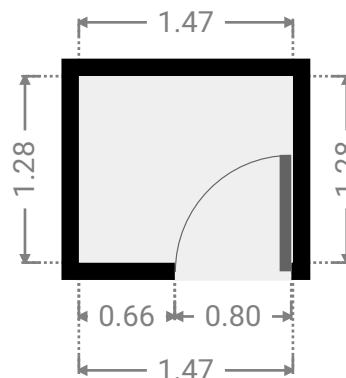
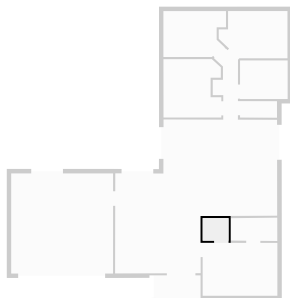

▼ Bathroom
Ground Floor

WIDTH: 2.66 m • LENGTH: 1.32 m
AREA: 3.43 m² • PERIMETER: 7.88 m

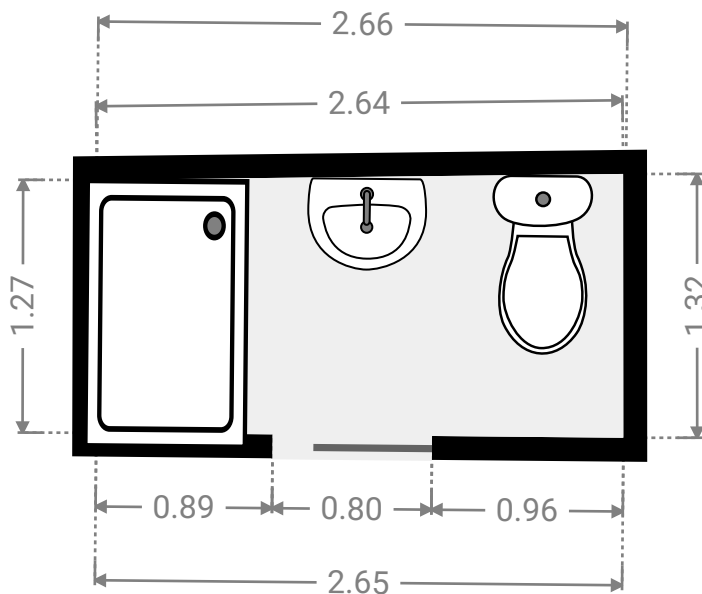
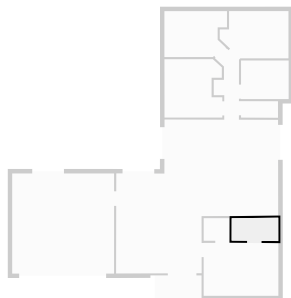

▼ Other
Ground Floor

WIDTH: 2.53 m • LENGTH: 1.16 m
AREA: 2.94 m² • PERIMETER: 7.39 m

