

394 Feez Street

Created on
2021-03-09

Floors
3

▼ Ground Floor

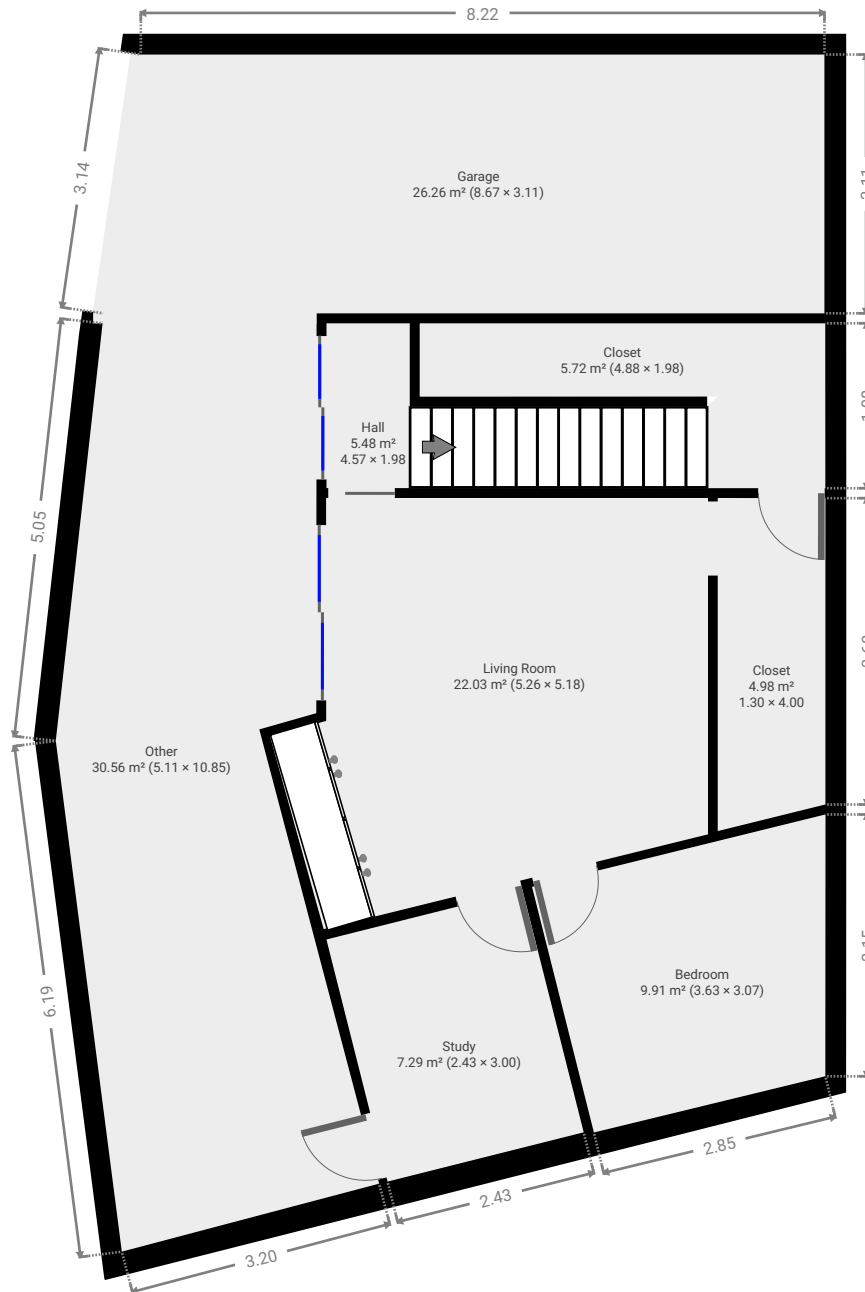

▼ **Hall**
Ground Floor

WIDTH: 1.98 m • LENGTH: 4.57 m
AREA: 5.48 m² • PERIMETER: 13.11 m

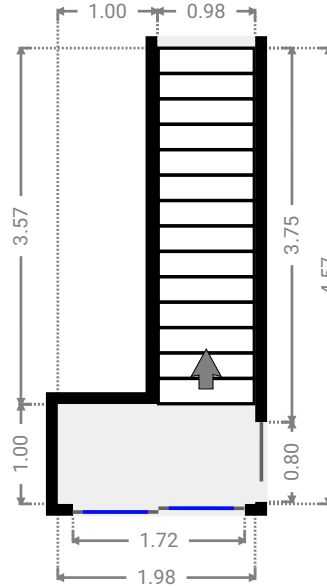
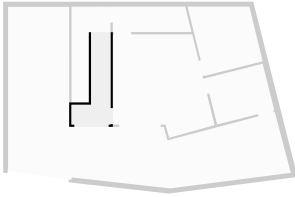

▼ **Living Room**
Ground Floor

WIDTH: 5.18 m • LENGTH: 5.26 m
AREA: 22.03 m² • PERIMETER: 19.17 m

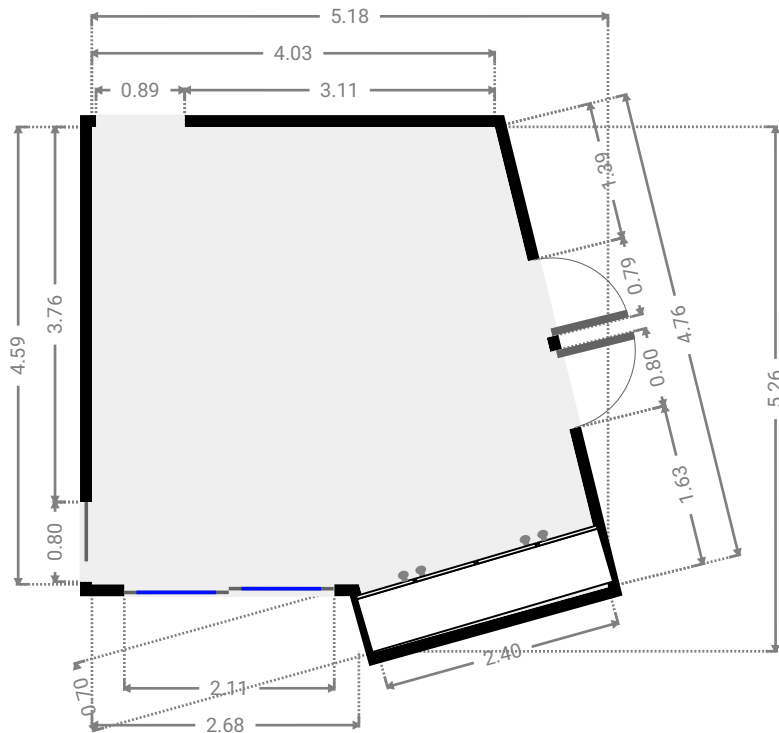
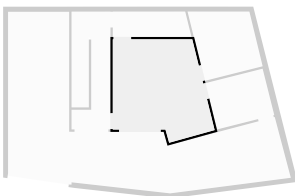

▼ **Study**
Ground Floor

WIDTH: 3.00 m • LENGTH: 2.43 m
AREA: 7.29 m² • PERIMETER: 10.86 m

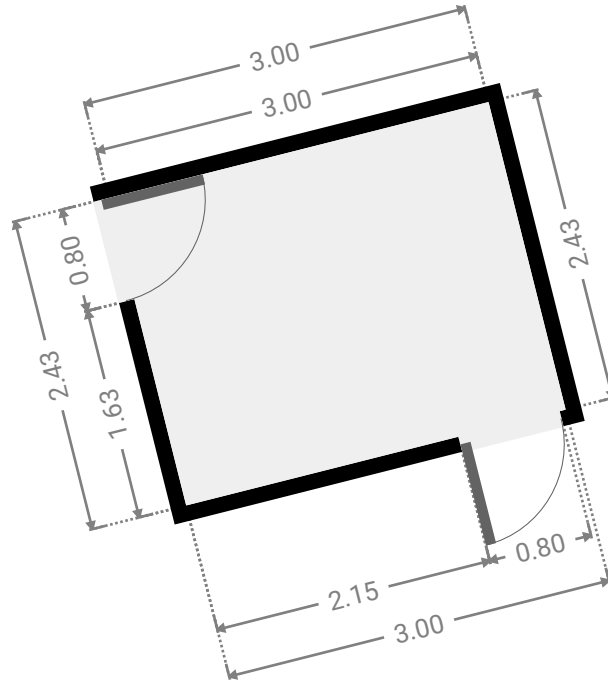
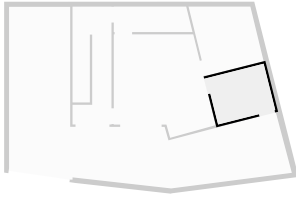

▼ **Bedroom**
Ground Floor

WIDTH: 3.07 m • LENGTH: 3.63 m
AREA: 9.91 m² • PERIMETER: 12.69 m

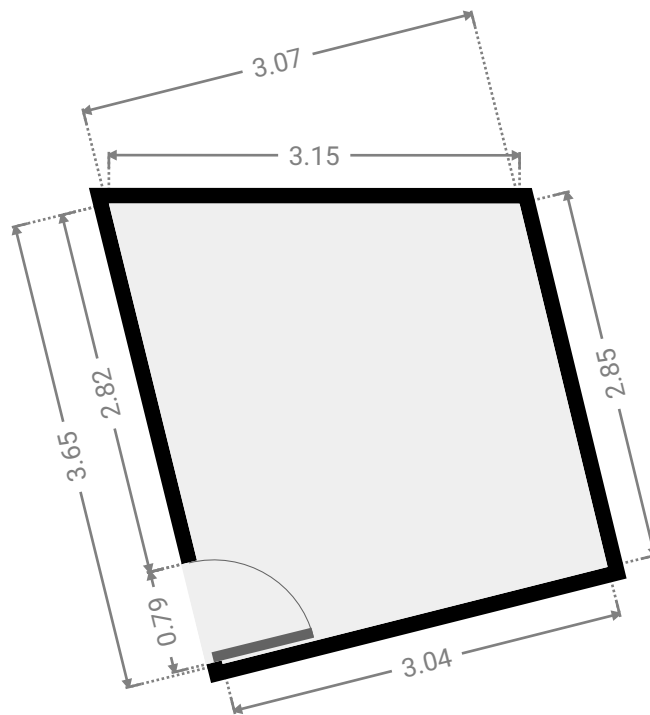
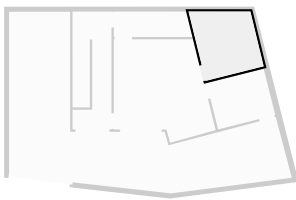

▼ **Closet**
Ground Floor

WIDTH: 4.00 m • LENGTH: 1.30 m
AREA: 4.98 m² • PERIMETER: 10.31 m

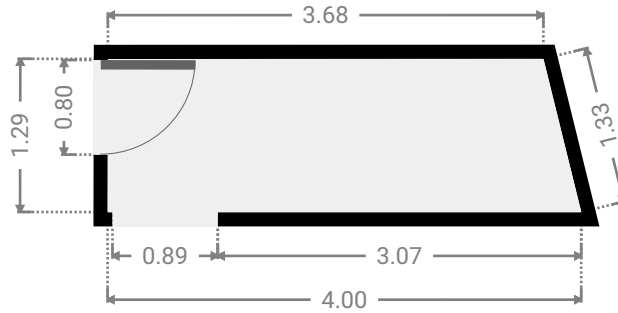
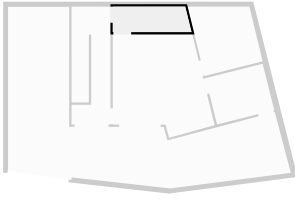

▼ **Closet**
Ground Floor

WIDTH: 1.98 m • LENGTH: 4.88 m
AREA: 5.72 m² • PERIMETER: 13.71 m

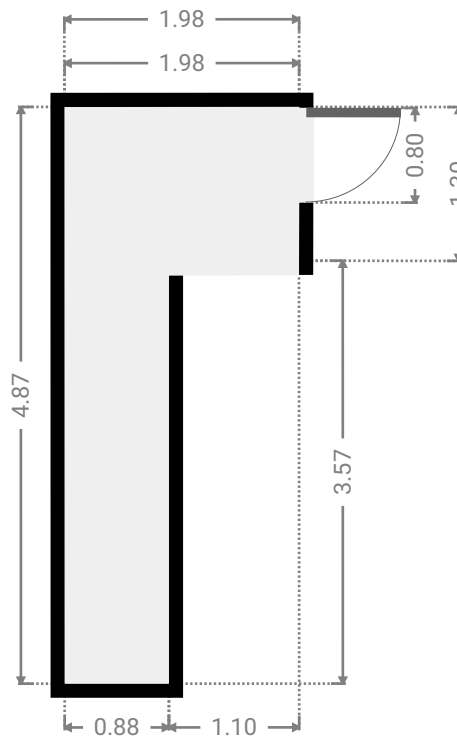
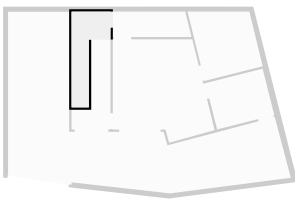

▼ **Garage**
Ground Floor

WIDTH: 3.11 m • LENGTH: 8.67 m
AREA: 26.26 m² • PERIMETER: 23.14 m

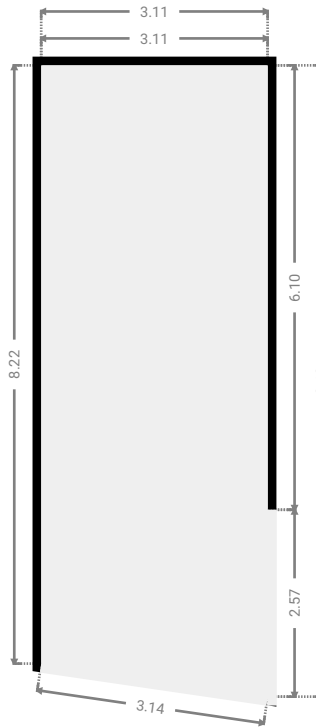
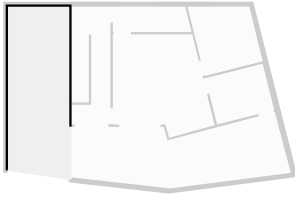

▼ **Other**
Ground Floor

WIDTH: 10.85 m • LENGTH: 5.11 m
AREA: 30.56 m² • PERIMETER: 28.05 m

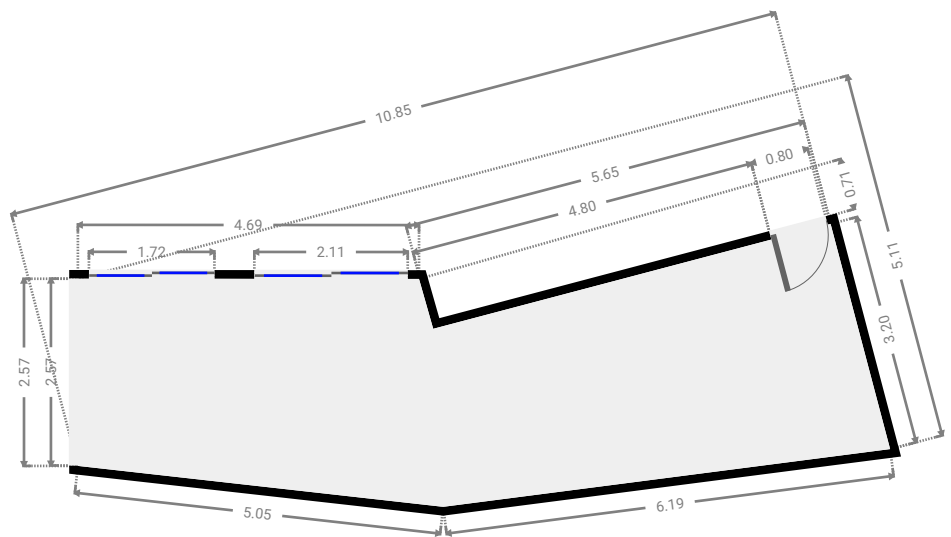
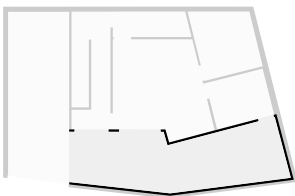

▼ 1st Floor

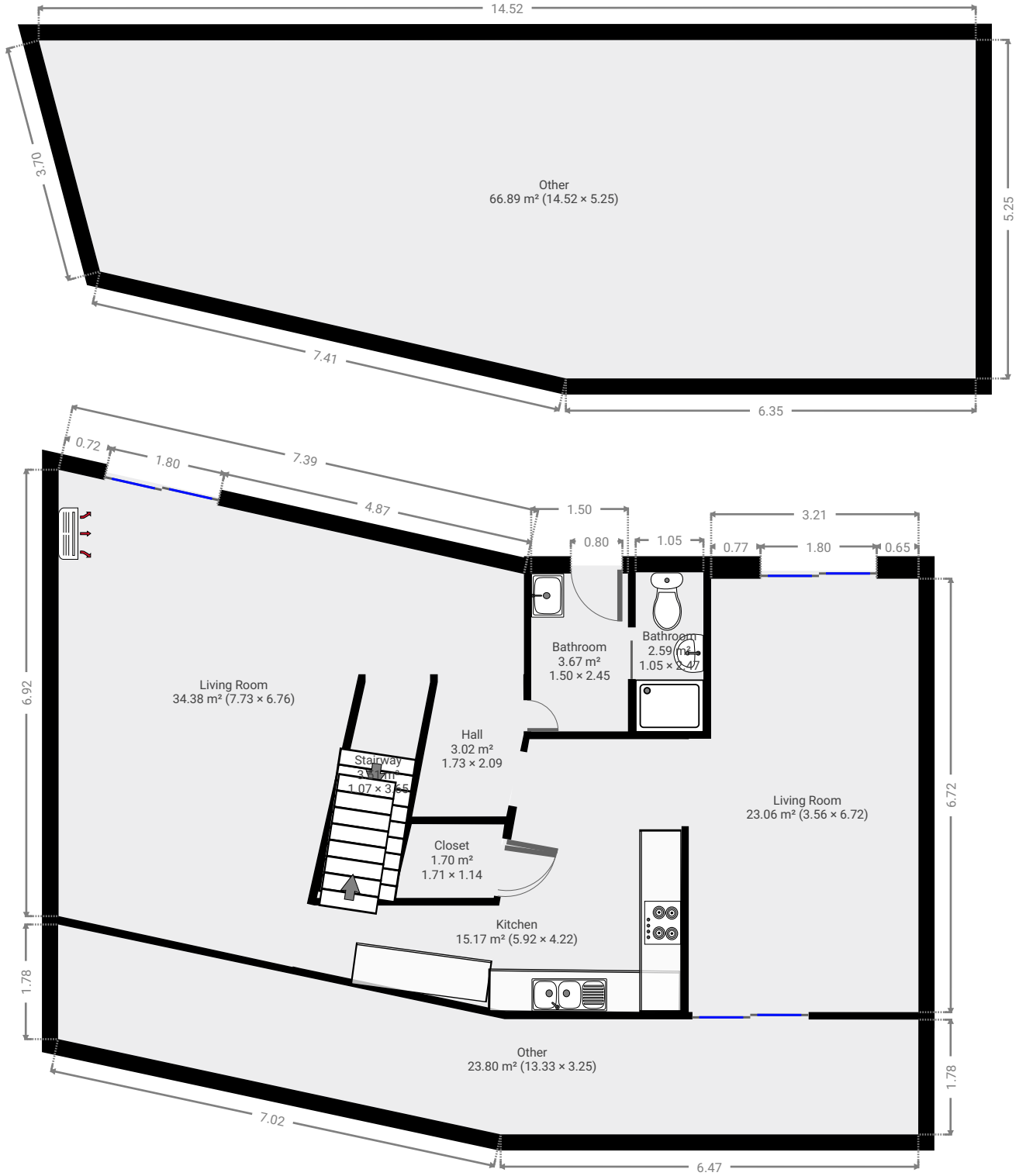

▼ Living Room
1st Floor

WIDTH: 7.73 m • LENGTH: 6.76 m
AREA: 34.38 m² • PERIMETER: 26.79 m

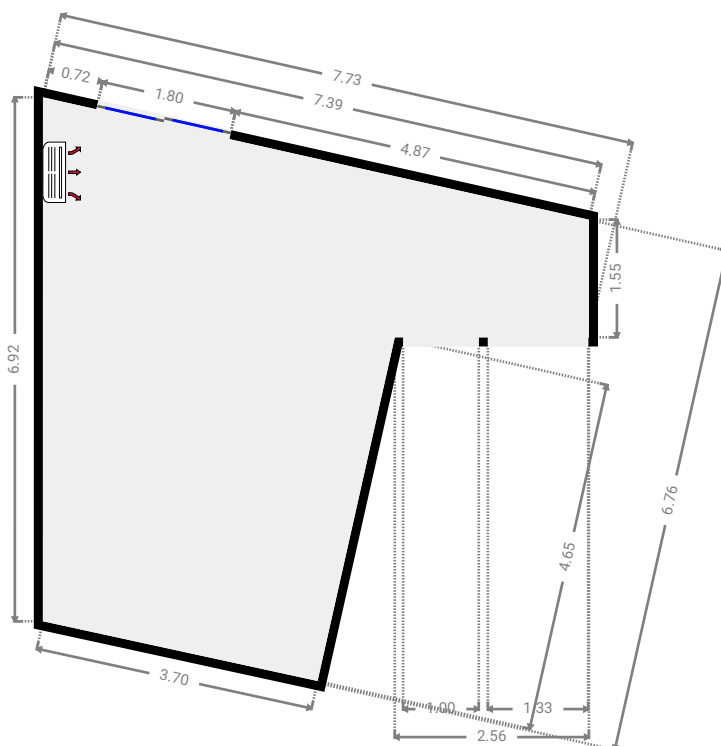
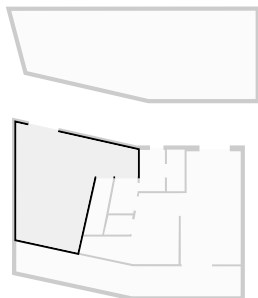

▼ Kitchen
1st Floor

WIDTH: 5.92 m • LENGTH: 4.22 m
AREA: 15.17 m² • PERIMETER: 19.03 m

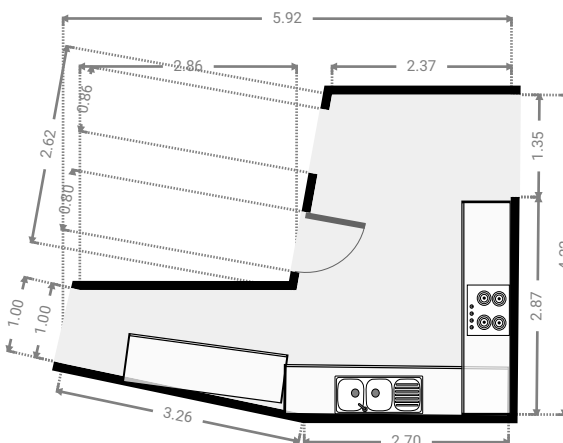
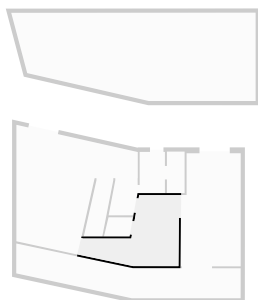

▼ **Closet**
1st Floor

WIDTH: 1.71 m • LENGTH: 1.14 m
AREA: 1.70 m² • PERIMETER: 5.30 m

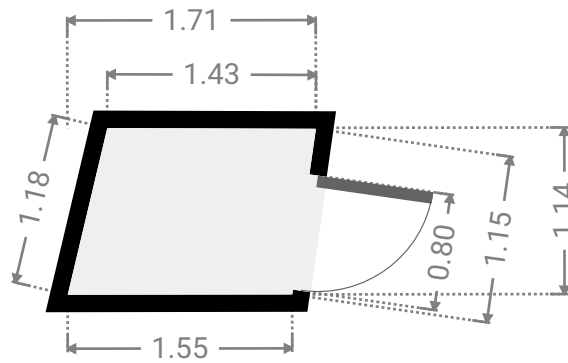
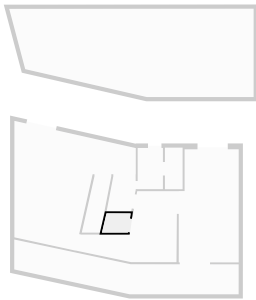

▼ **Stairway**
1st Floor

WIDTH: 1.07 m • LENGTH: 3.65 m
AREA: 3.51 m² • PERIMETER: 8.94 m

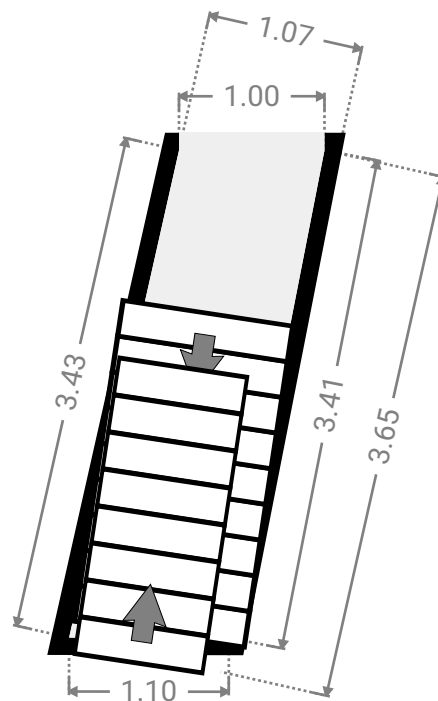
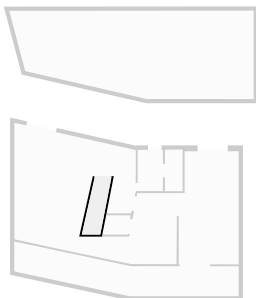

▼ **Hall**
1st Floor

WIDTH: 1.73 m • LENGTH: 2.09 m
AREA: 3.02 m² • PERIMETER: 7.02 m

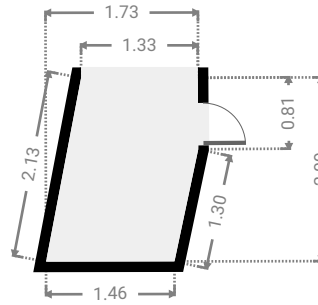
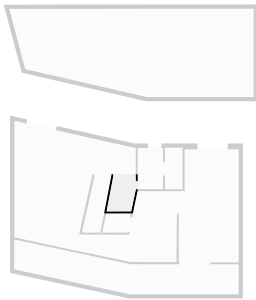

▼ **Living Room**
1st Floor

WIDTH: 3.56 m • LENGTH: 6.72 m
AREA: 23.06 m² • PERIMETER: 20.56 m

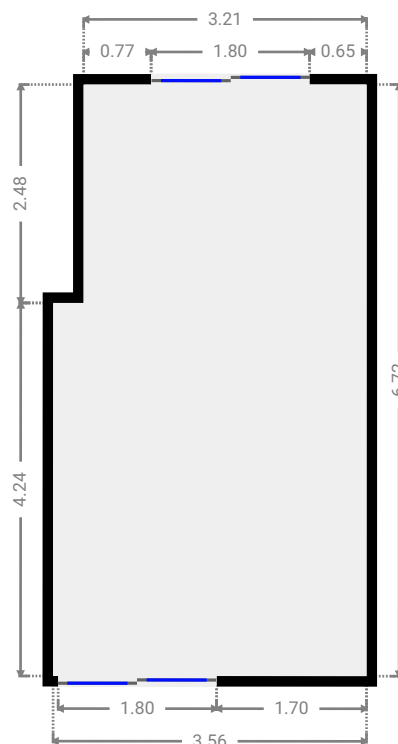
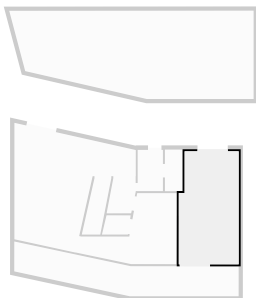

▼ Other
1st Floor

WIDTH: 13.33 m • LENGTH: 3.25 m
AREA: 23.80 m² • PERIMETER: 30.53 m

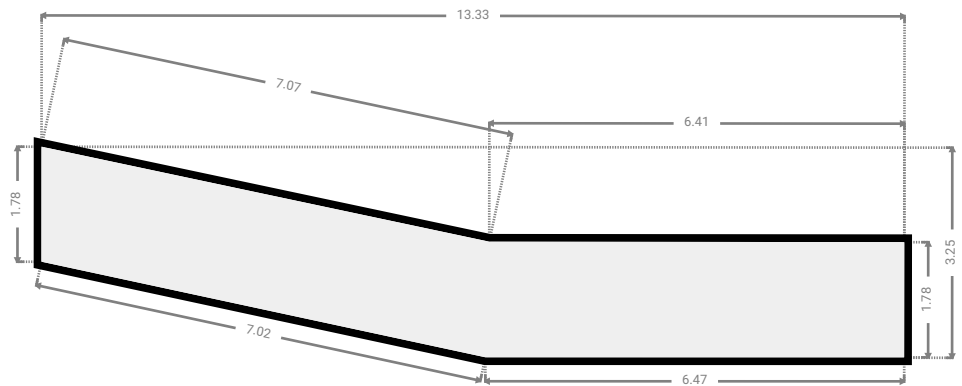
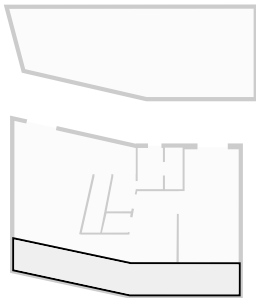

▼ Bathroom
1st Floor

WIDTH: 1.05 m • LENGTH: 2.47 m
AREA: 2.59 m² • PERIMETER: 7.04 m

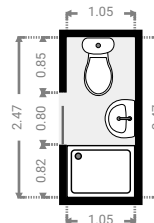
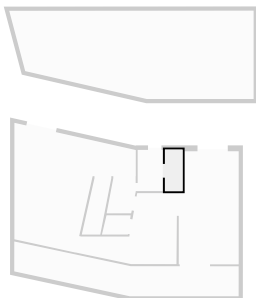

▼ **Bathroom**
1st Floor

WIDTH: 1.50 m • LENGTH: 2.45 m
AREA: 3.67 m² • PERIMETER: 7.89 m

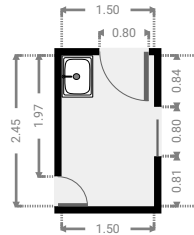
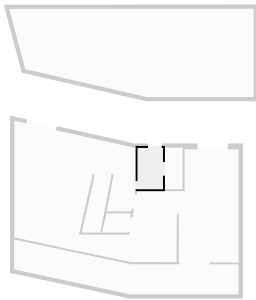

▼ **Other**
1st Floor

WIDTH: 14.52 m • LENGTH: 5.25 m
AREA: 66.89 m² • PERIMETER: 37.24 m

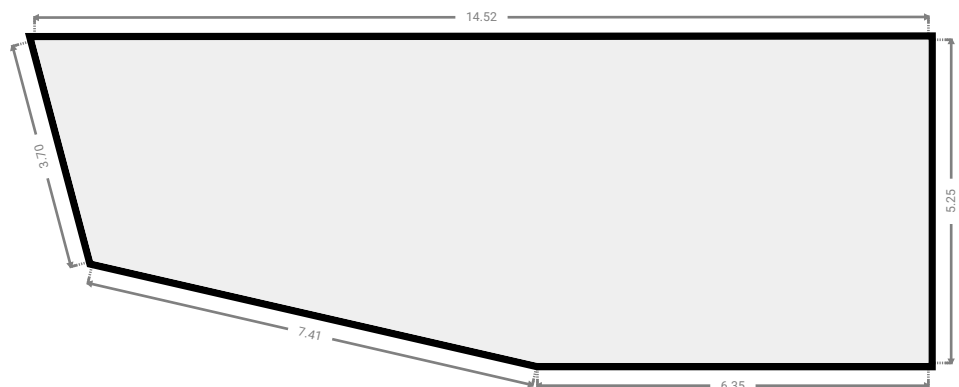
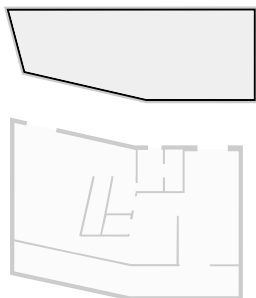

▼ 2nd Floor

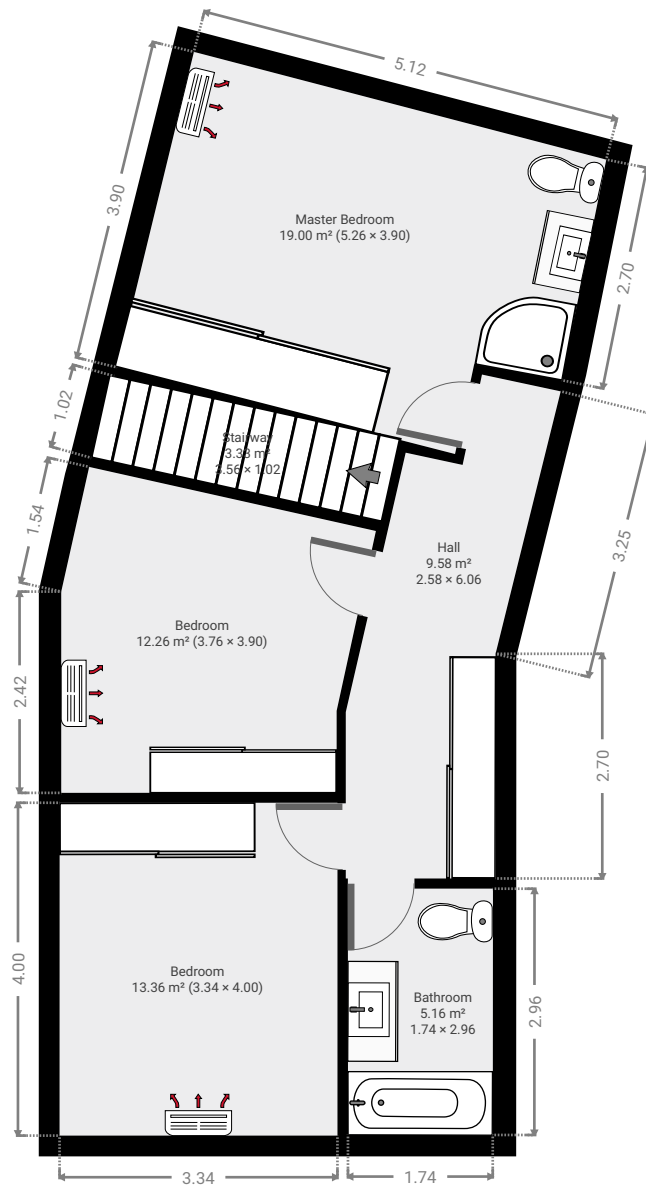

▼ **Hall**
2nd Floor

WIDTH: 6.06 m • LENGTH: 2.58 m
AREA: 9.58 m² • PERIMETER: 15.73 m

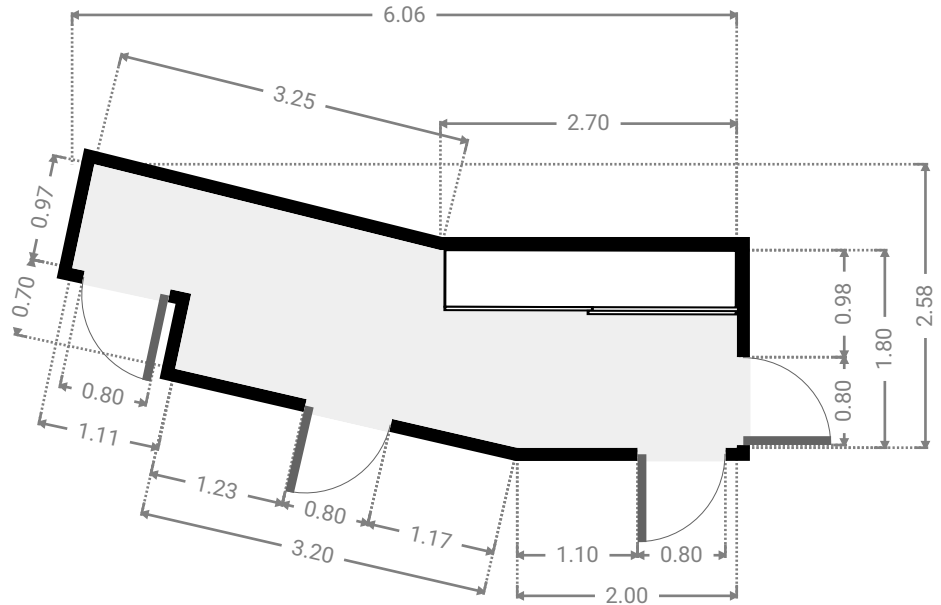
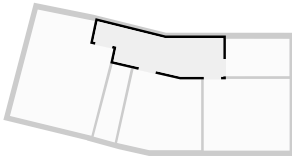

▼ **Bathroom**
2nd Floor

WIDTH: 2.96 m • LENGTH: 1.74 m
AREA: 5.16 m² • PERIMETER: 9.40 m

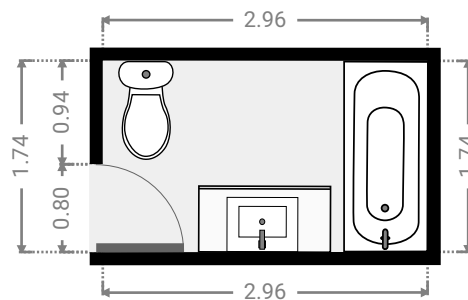
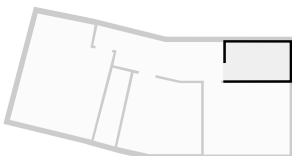

▼ **Bedroom**
2nd Floor

WIDTH: 4.00 m • LENGTH: 3.34 m
AREA: 13.36 m² • PERIMETER: 14.68 m

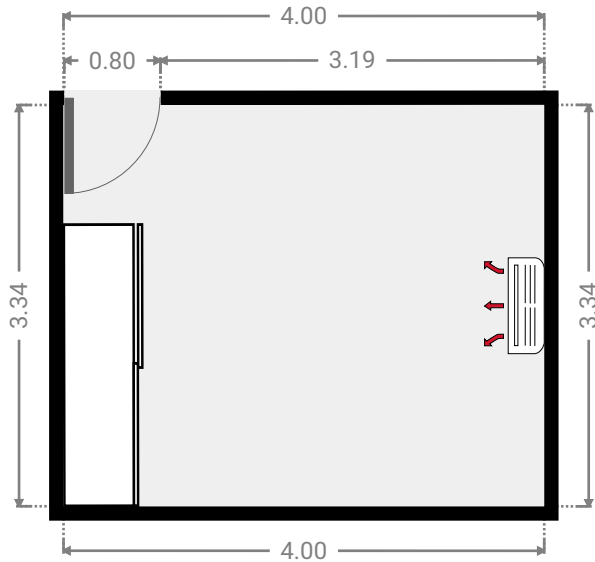
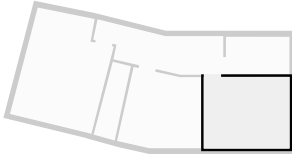

▼ **Bedroom**
2nd Floor

WIDTH: 3.90 m • LENGTH: 3.76 m
AREA: 12.26 m² • PERIMETER: 13.99 m

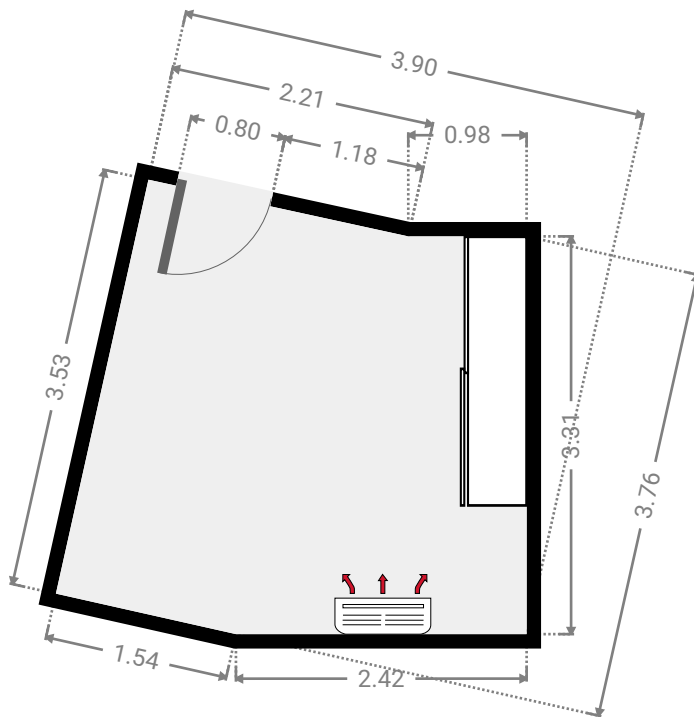
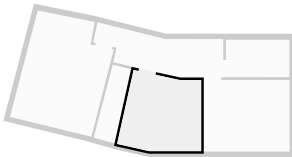

▼ **Stairway**
2nd Floor

WIDTH: 1.02 m • LENGTH: 3.56 m
AREA: 3.33 m² • PERIMETER: 8.94 m

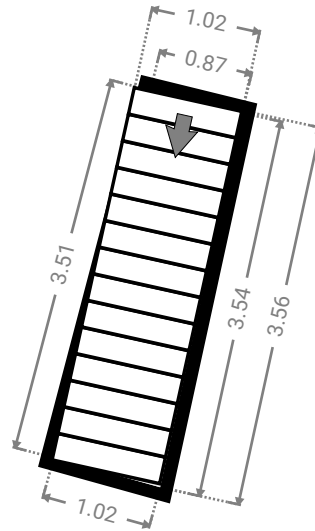
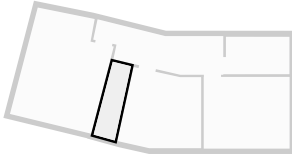

▼ **Master Bedroom**
2nd Floor

WIDTH: 3.90 m • LENGTH: 5.26 m
AREA: 19.00 m² • PERIMETER: 18.10 m

