

293 Berserker Street

Created on
2021-09-28

Floors
2

▼ Ground Floor

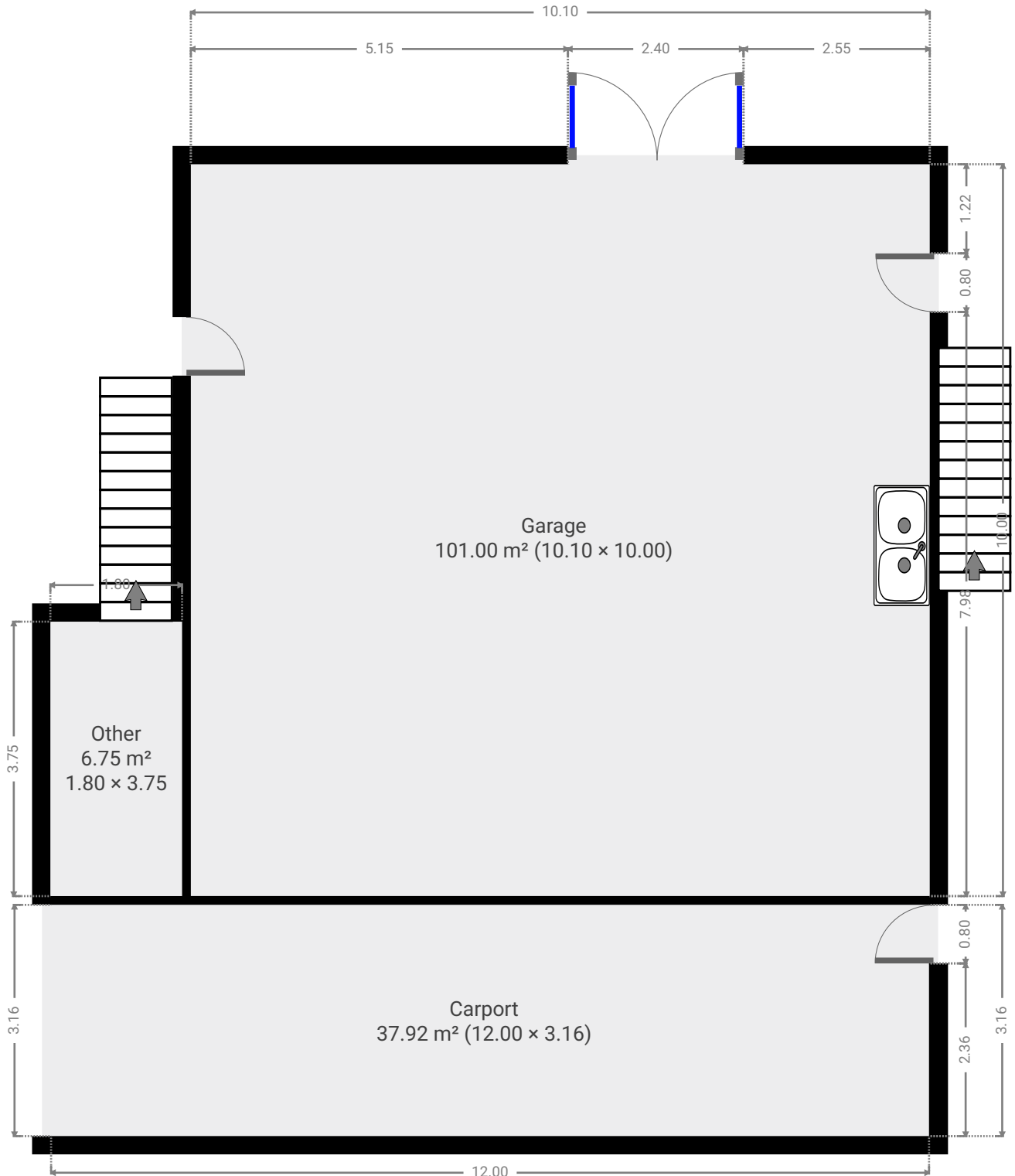

▼ **Garage**
Ground Floor

WIDTH: 10.00 m • LENGTH: 10.10 m
AREA: 101.00 m² • PERIMETER: 40.20 m

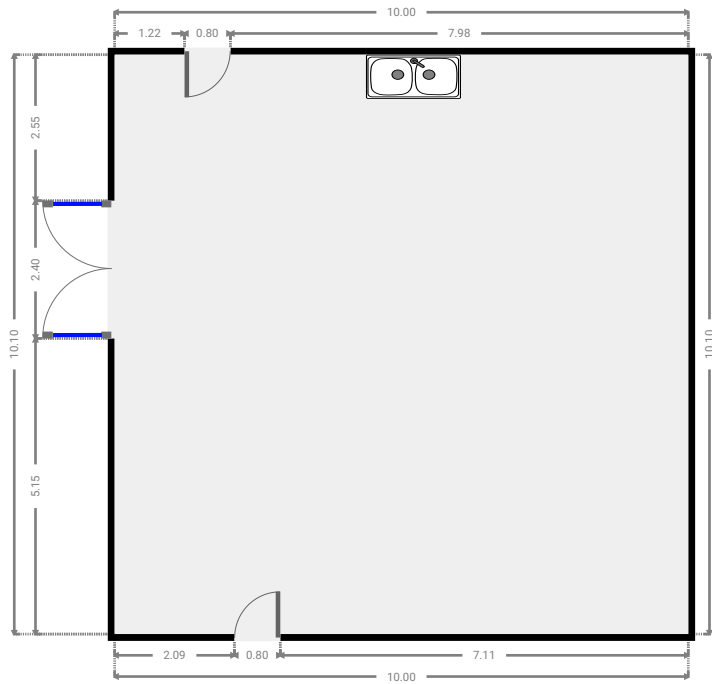
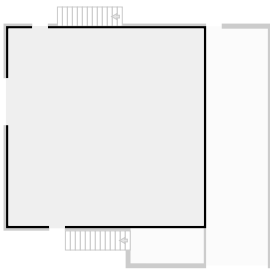

▼ **Carport**
Ground Floor

WIDTH: 3.16 m • LENGTH: 12.00 m
AREA: 37.92 m² • PERIMETER: 30.32 m

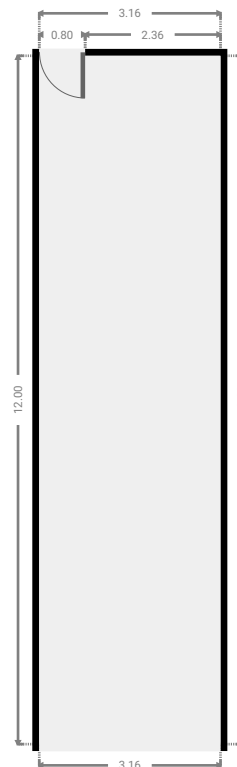
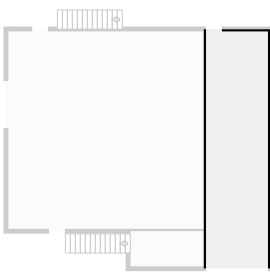

▼ Other
Ground Floor

WIDTH: 3.75 m • LENGTH: 1.80 m
AREA: 6.75 m² • PERIMETER: 11.10 m

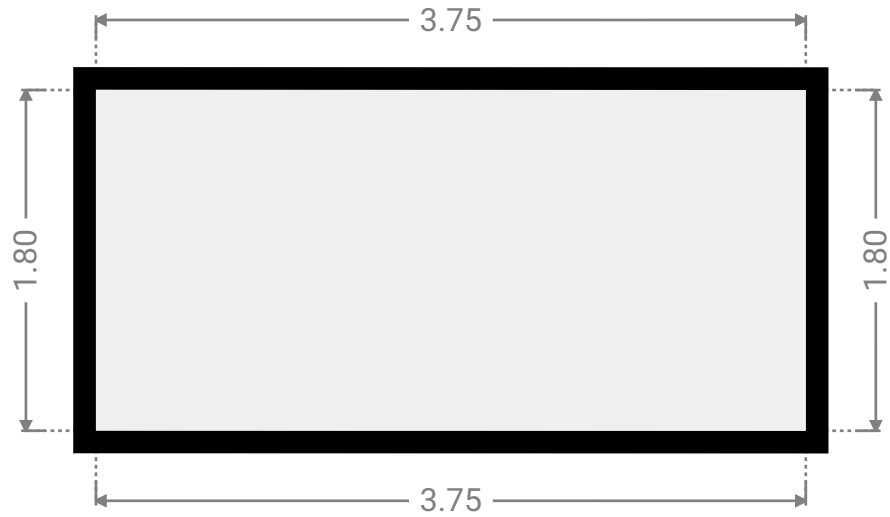
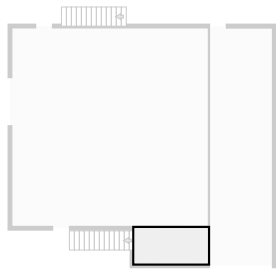

▼ 1st Floor

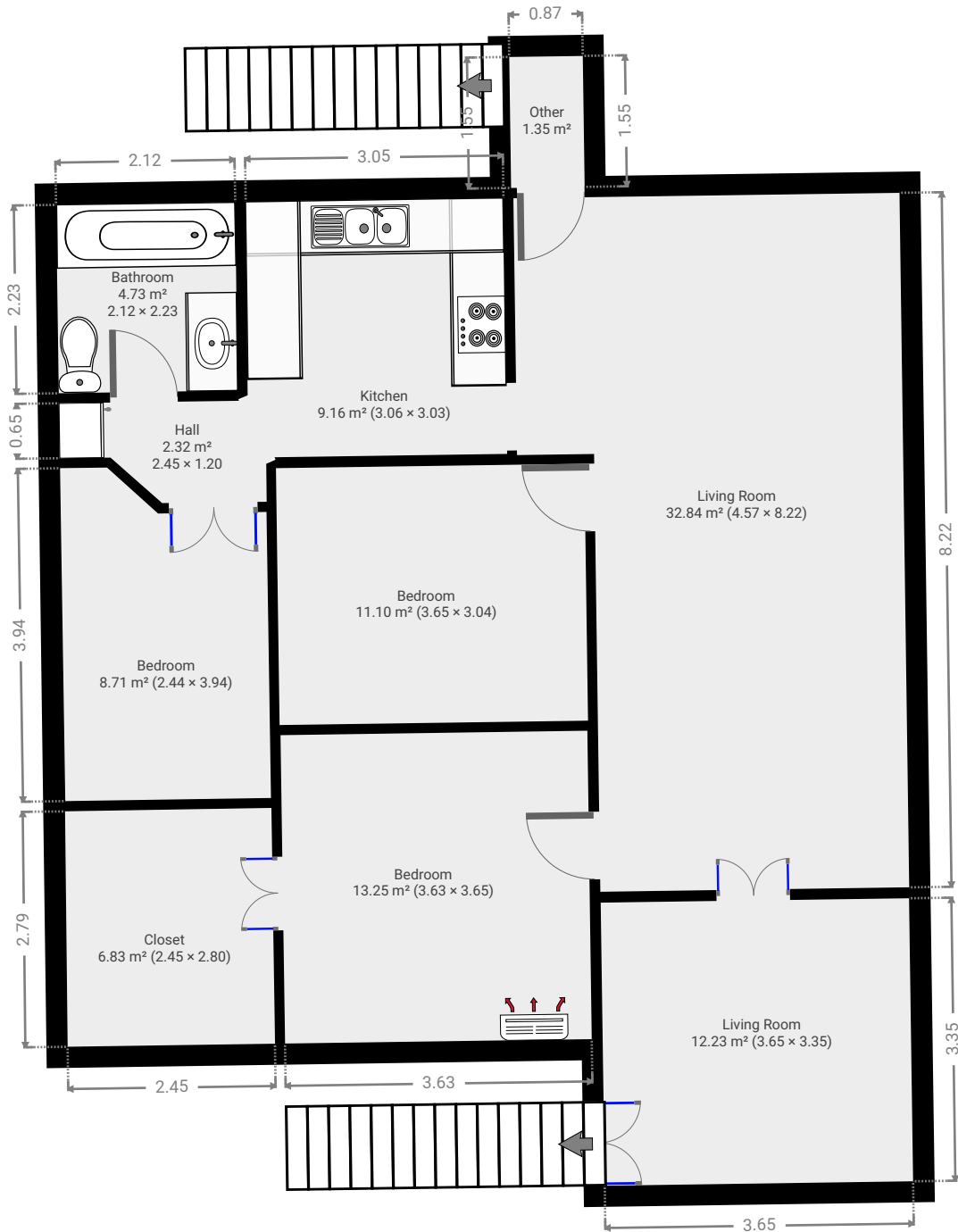

▼ Living Room
1st Floor

WIDTH: 3.65 m • LENGTH: 3.35 m
AREA: 12.23 m² • PERIMETER: 14.00 m

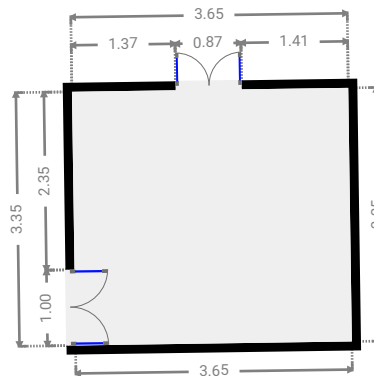
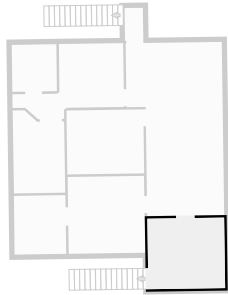

▼ Living Room
1st Floor

WIDTH: 4.57 m • LENGTH: 8.22 m
AREA: 32.84 m² • PERIMETER: 25.58 m

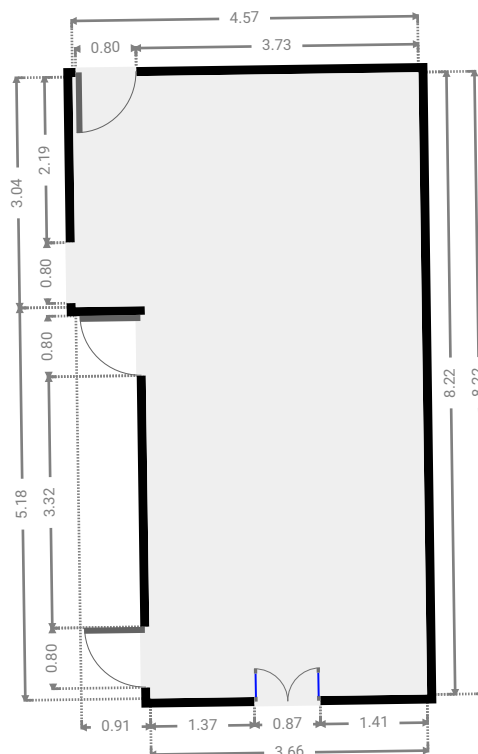
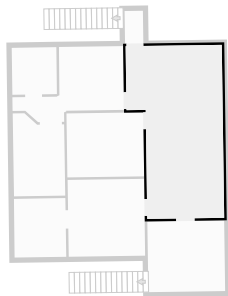

▼ **Bedroom**
1st Floor

WIDTH: 3.63 m • LENGTH: 3.65 m
AREA: 13.25 m² • PERIMETER: 14.56 m

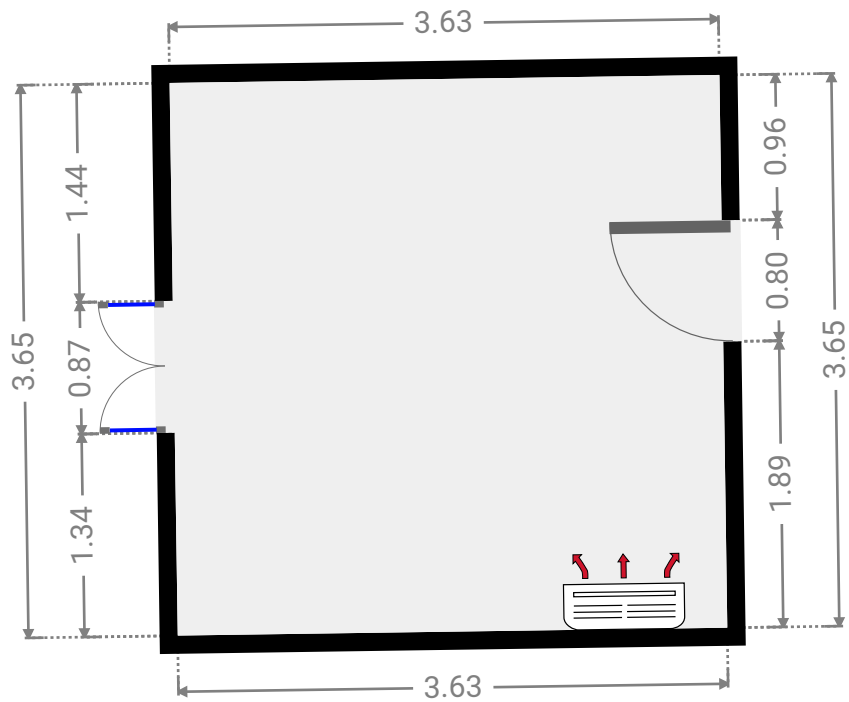
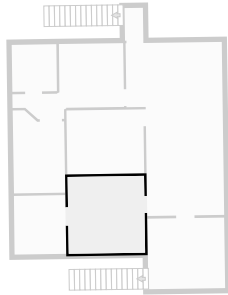

▼ **Bedroom**
1st Floor

WIDTH: 3.65 m • LENGTH: 3.04 m
AREA: 11.10 m² • PERIMETER: 13.38 m

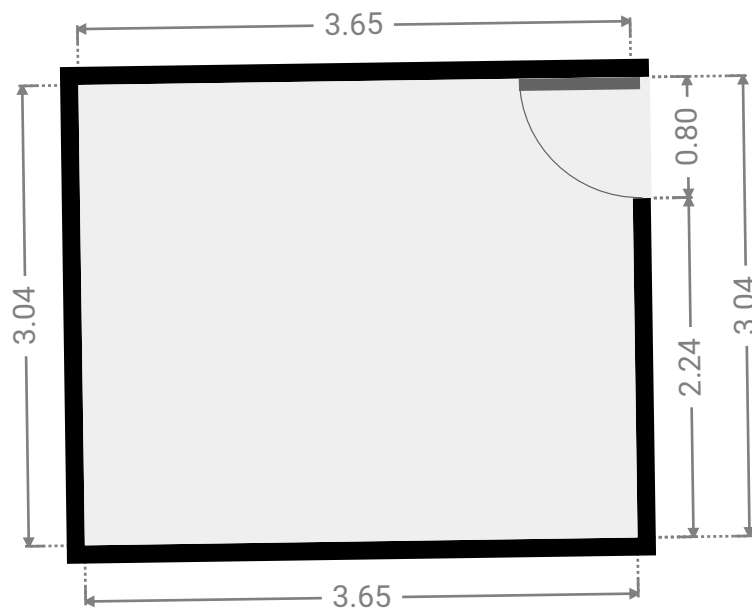
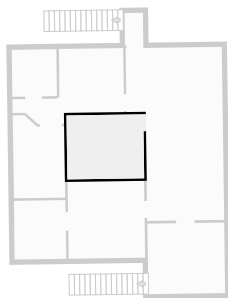

▼ **Kitchen**
1st Floor

WIDTH: 3.06 m • LENGTH: 3.03 m
AREA: 9.16 m² • PERIMETER: 11.93 m

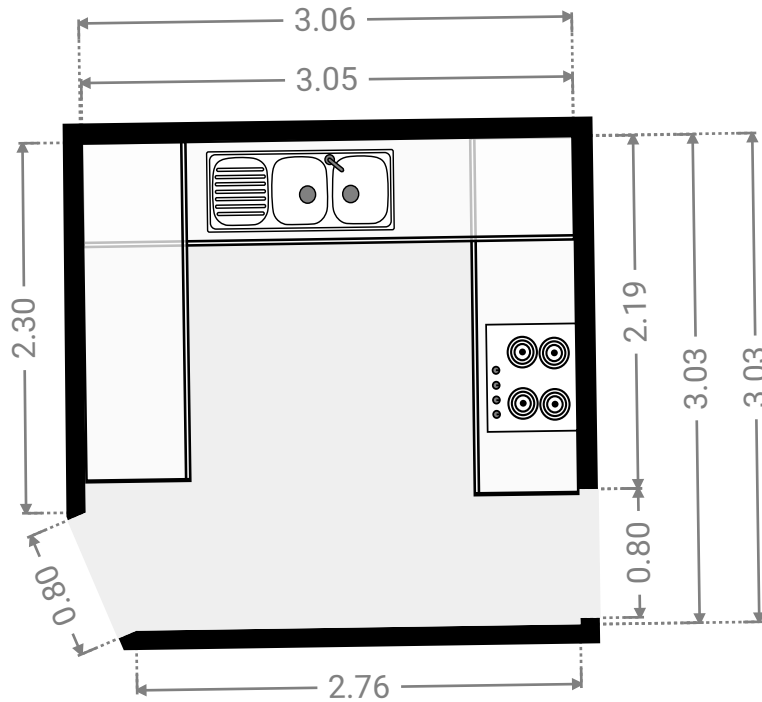
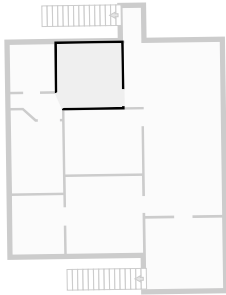

▼ **Hall**
1st Floor

WIDTH: 2.45 m • LENGTH: 1.20 m
AREA: 2.32 m² • PERIMETER: 6.70 m

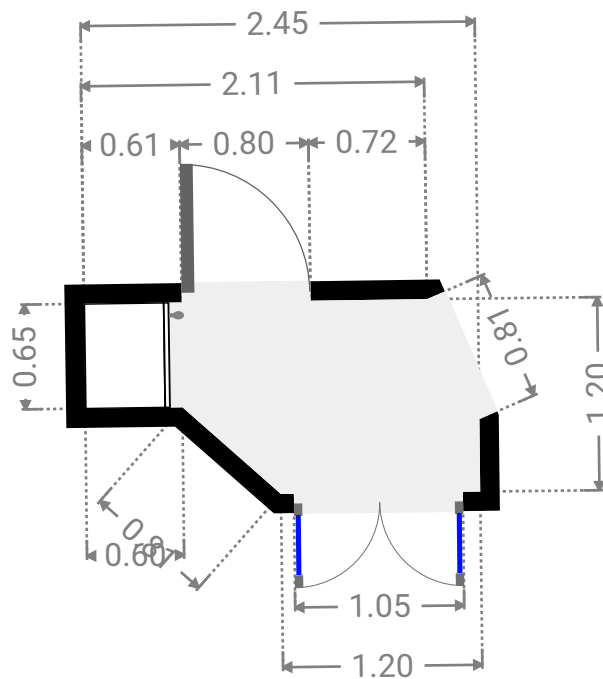
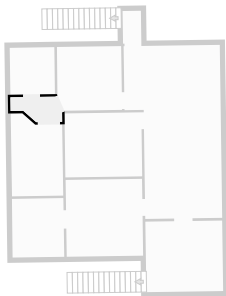

▼ **Bedroom**
1st Floor

WIDTH: 2.44 m • LENGTH: 3.94 m
AREA: 8.71 m² • PERIMETER: 12.41 m

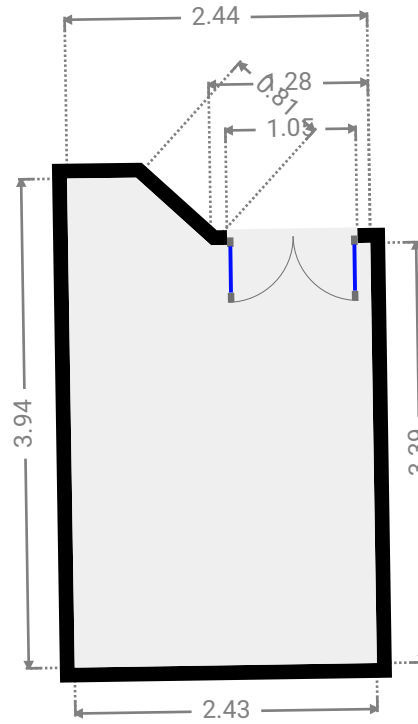
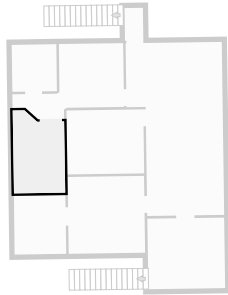

▼ **Bathroom**
1st Floor

WIDTH: 2.12 m • LENGTH: 2.23 m
AREA: 4.73 m² • PERIMETER: 8.70 m

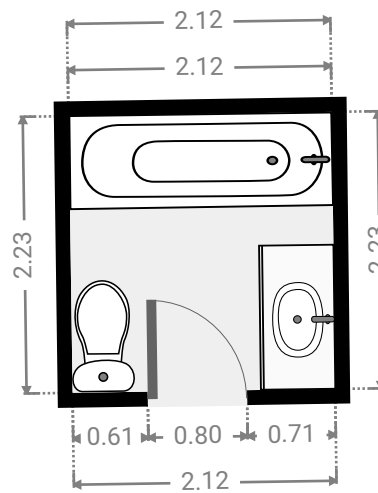
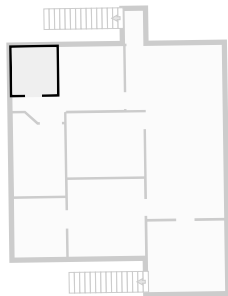

▼ Other
1st Floor

WIDTH: 0.87 m • LENGTH: 1.55 m
AREA: 1.35 m² • PERIMETER: 4.84 m

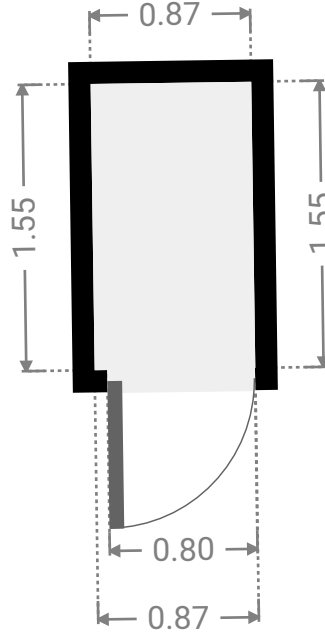
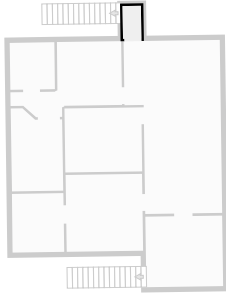

▼ Closet
1st Floor

WIDTH: 2.45 m • LENGTH: 2.80 m
AREA: 6.83 m² • PERIMETER: 10.47 m

