

388 Waterloo Street

SUBMITTED BY
Ray White Rockhampton Casey
stockers@cqoz.com

CREATED ON
2022-03-09

Floors
2

▼ Ground Floor

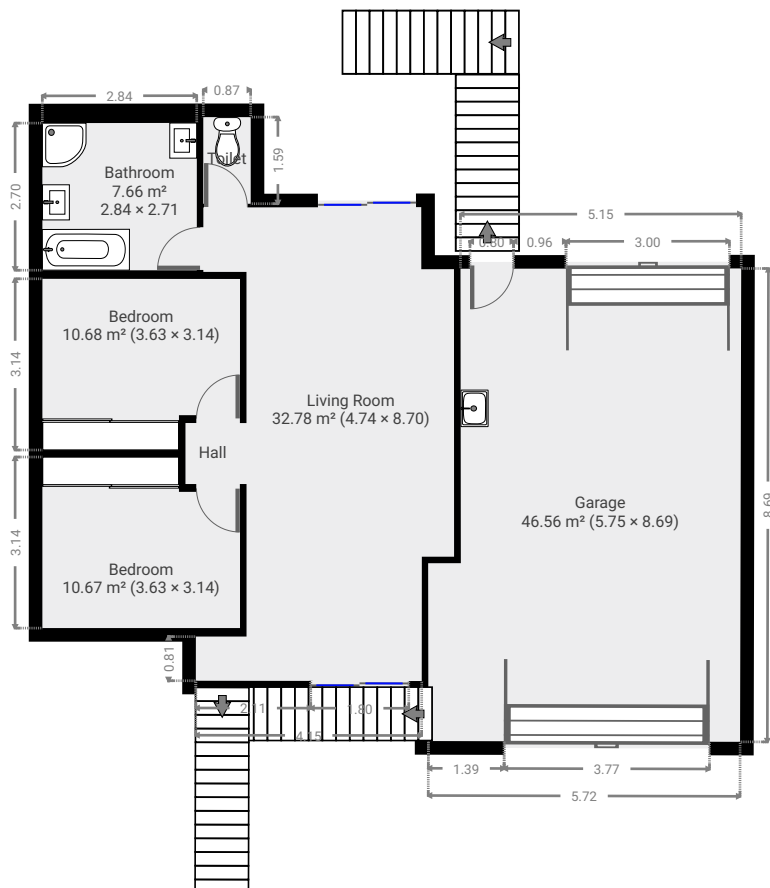
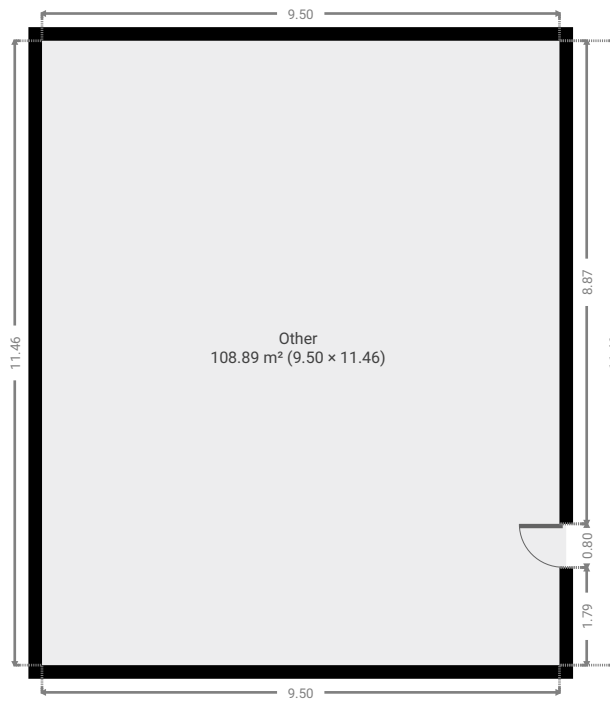

FLOORS: 2

▼ Garage
Ground Floor

WIDTH: 5.75 m • LENGTH: 8.69 m
AREA: 46.56 m² • PERIMETER: 28.84 m

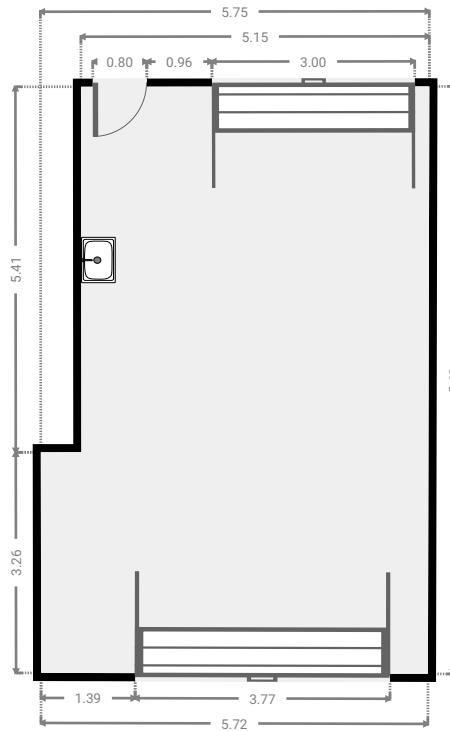
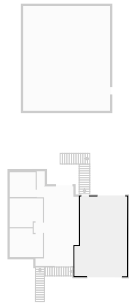

▼ Living Room
Ground Floor

WIDTH: 4.60 m • LENGTH: 8.45 m
AREA: 32.78 m² • PERIMETER: 28.45 m

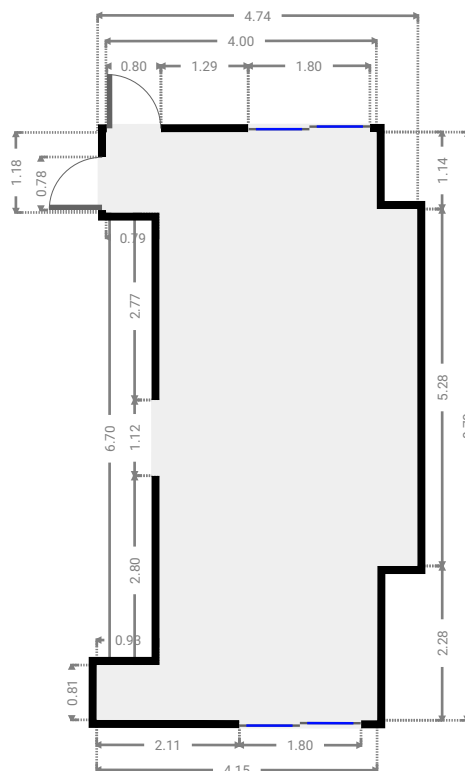
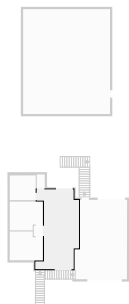

▼ **Hall**
Ground Floor

WIDTH: 1.00 m • LENGTH: 1.12 m
AREA: 1.12 m² • PERIMETER: 4.24 m

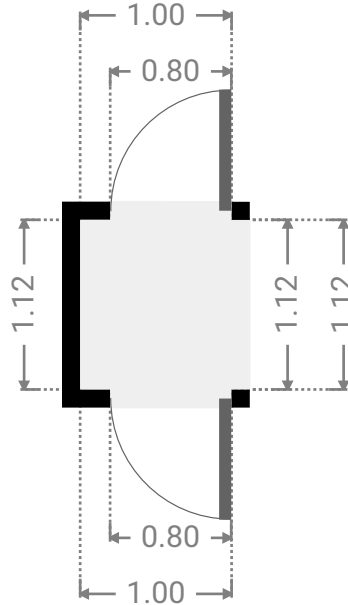
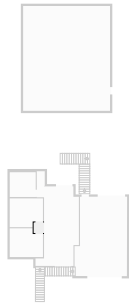

▼ **Bedroom**
Ground Floor

WIDTH: 3.60 m • LENGTH: 3.14 m
AREA: 10.68 m² • PERIMETER: 13.54 m

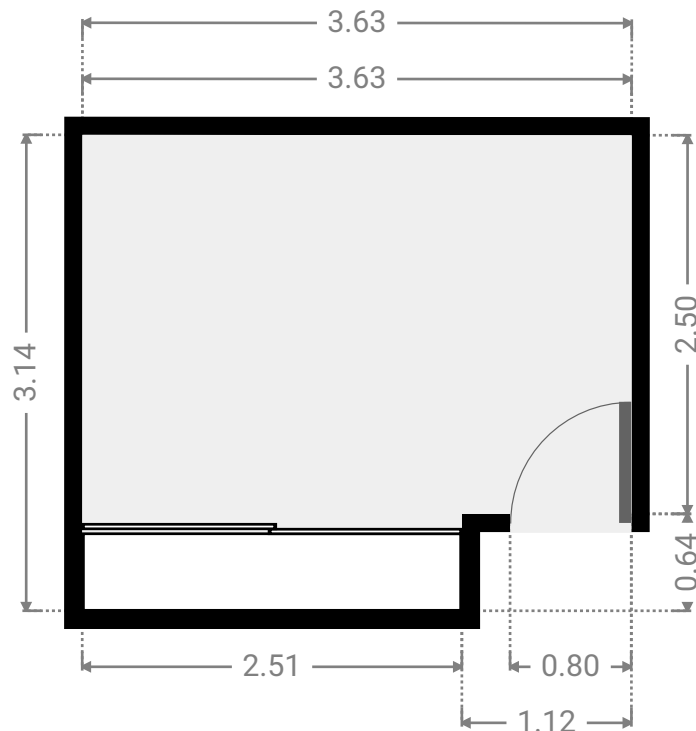
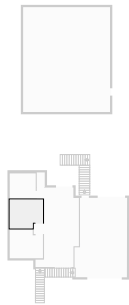

▼ **Bedroom**
Ground Floor

WIDTH: 3.60 m • LENGTH: 3.14 m
AREA: 10.67 m² • PERIMETER: 13.54 m

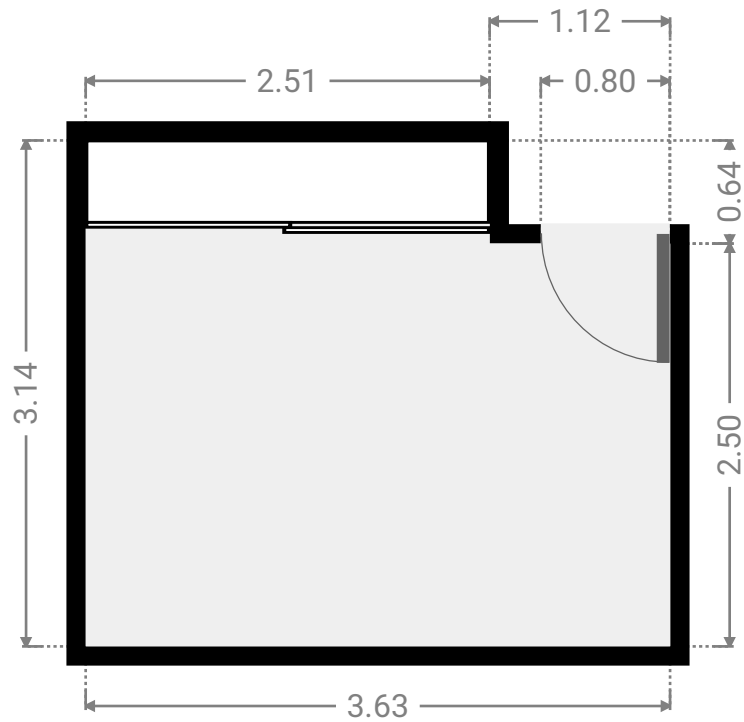
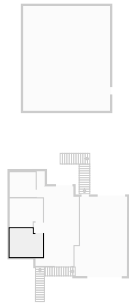

▼ **Toilet**
Ground Floor

WIDTH: 0.87 m • LENGTH: 1.59 m
AREA: 1.38 m² • PERIMETER: 4.92 m

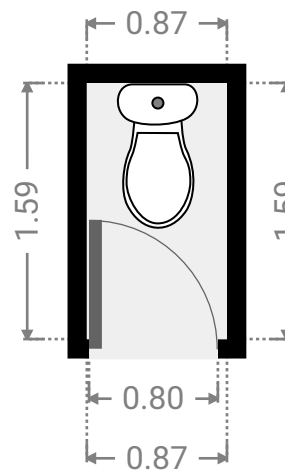
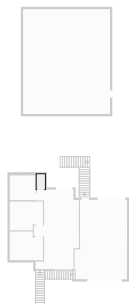

▼ Bathroom
Ground Floor

WIDTH: 2.45 m • LENGTH: 2.70 m
AREA: 7.66 m² • PERIMETER: 11.08 m

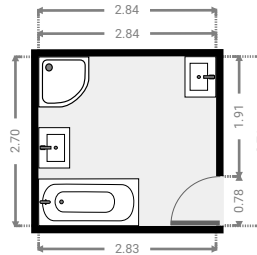
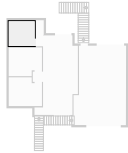

▼ Other
Ground Floor

WIDTH: 9.50 m • LENGTH: 11.46 m
AREA: 108.89 m² • PERIMETER: 41.92 m

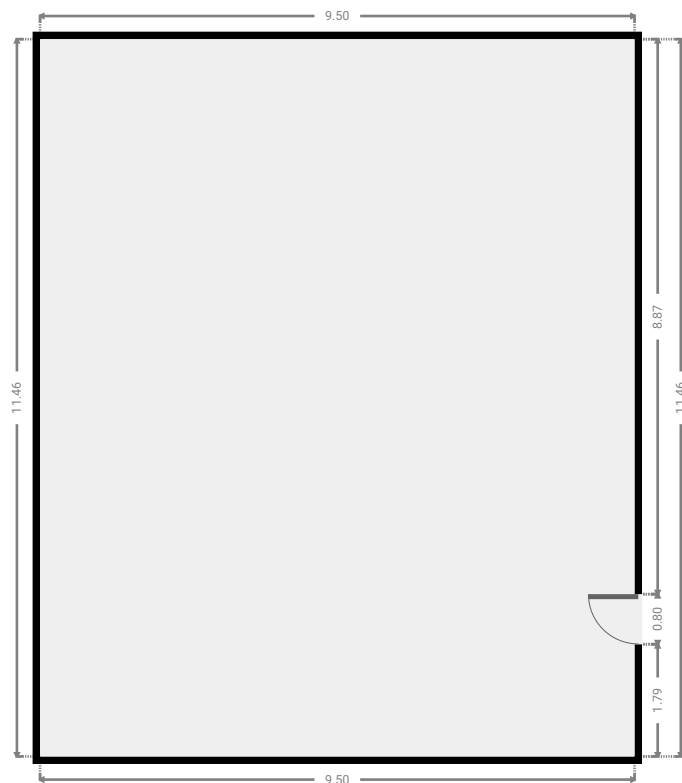
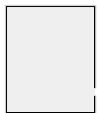

▼ 1st Floor

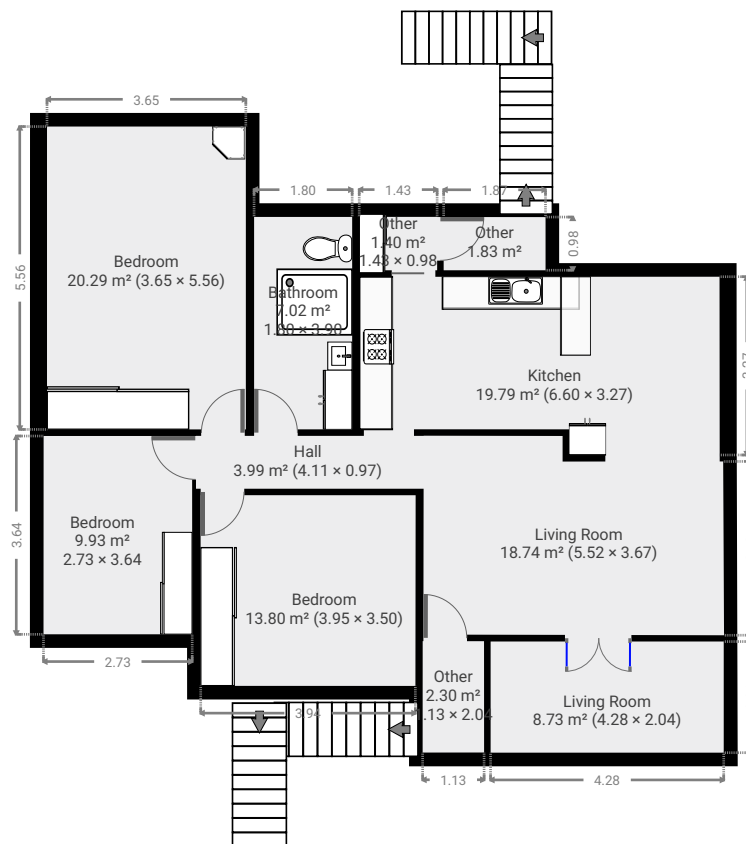

▼ **Living Room**
1st Floor

WIDTH: 5.52 m • LENGTH: 3.67 m
AREA: 18.74 m² • PERIMETER: 18.33 m

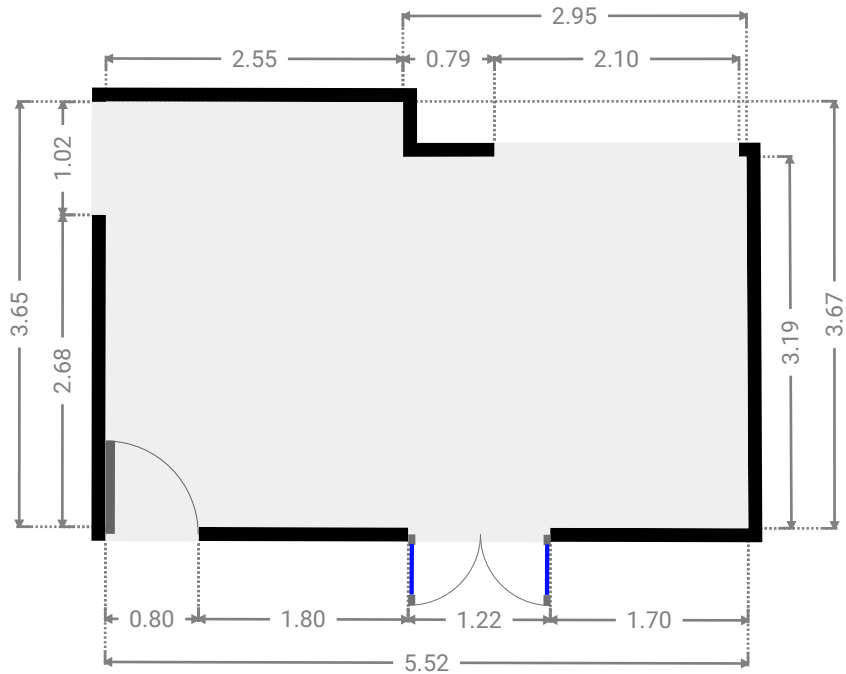
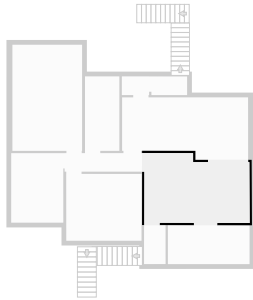

▼ **Kitchen**
1st Floor

WIDTH: 6.60 m • LENGTH: 3.27 m
AREA: 19.79 m² • PERIMETER: 19.75 m

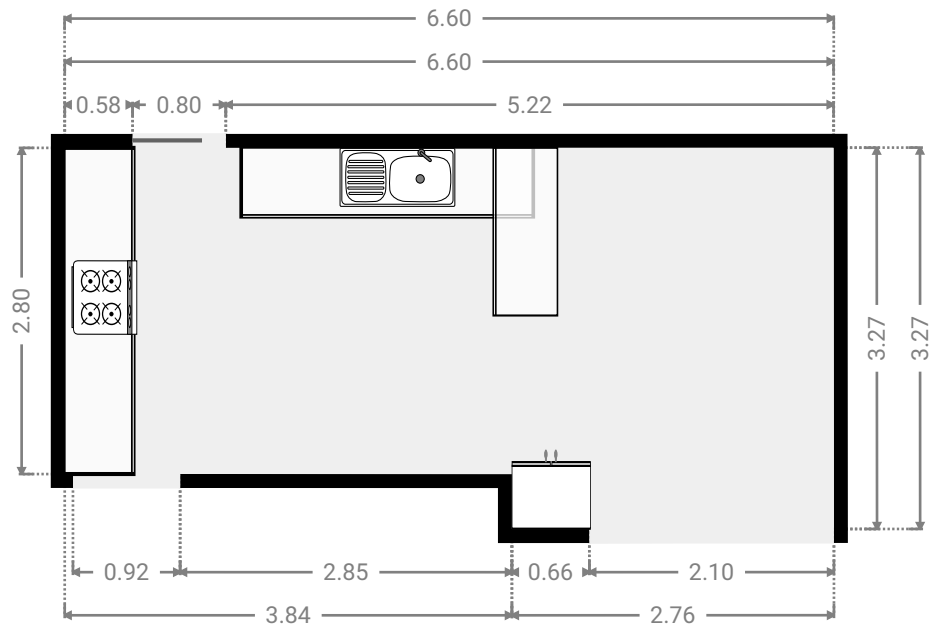
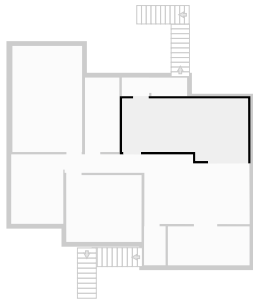

▼ **Living Room**
1st Floor

WIDTH: 4.28 m • LENGTH: 2.04 m
AREA: 8.73 m² • PERIMETER: 12.64 m

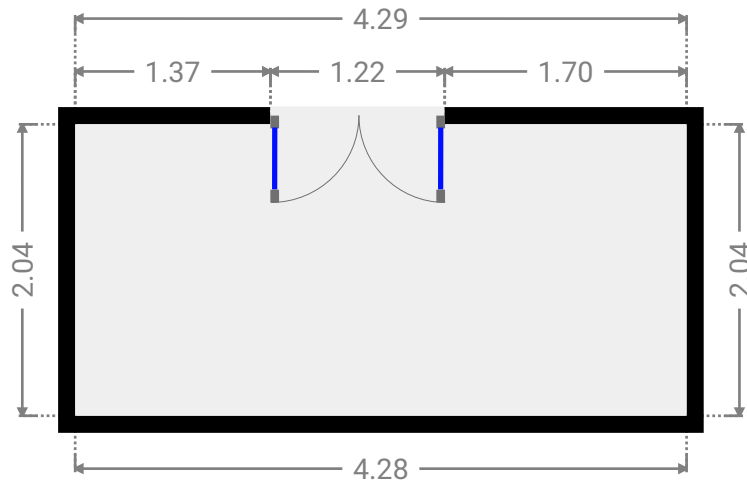
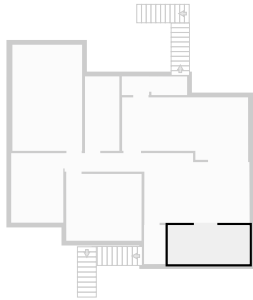

▼ **Hall**
1st Floor

WIDTH: 4.11 m • LENGTH: 0.97 m
AREA: 3.99 m² • PERIMETER: 10.16 m

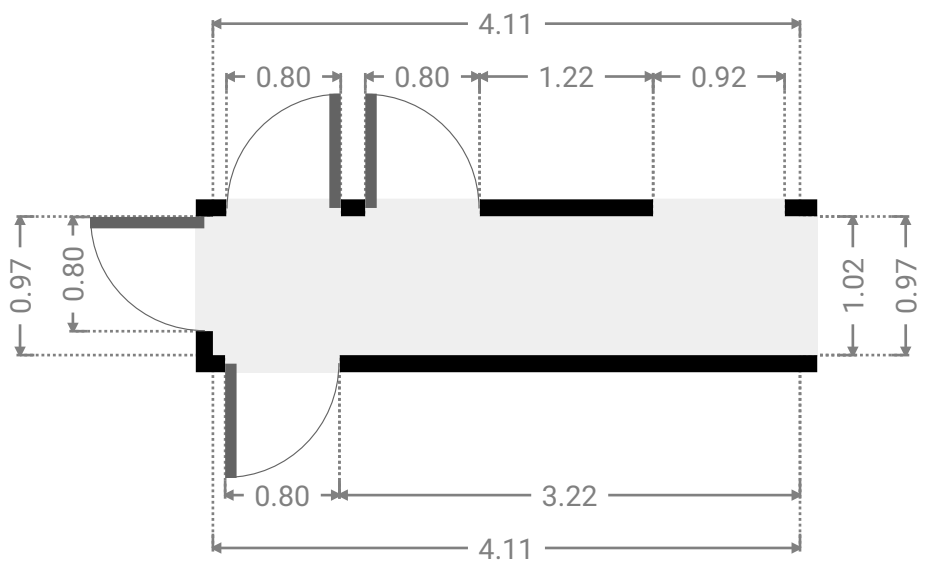
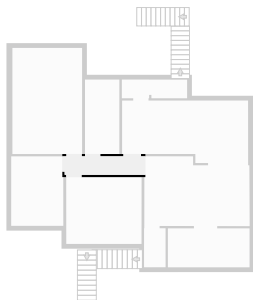

▼ **Bathroom**
1st Floor

WIDTH: 1.80 m • LENGTH: 3.90 m
AREA: 7.02 m² • PERIMETER: 11.40 m

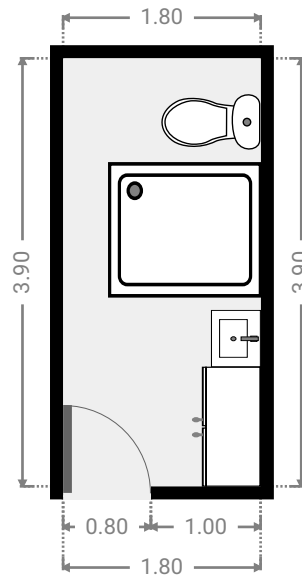
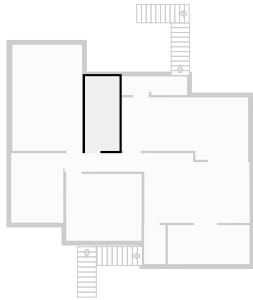

▼ **Bedroom**
1st Floor

WIDTH: 3.65 m • LENGTH: 5.56 m
AREA: 20.29 m² • PERIMETER: 18.42 m

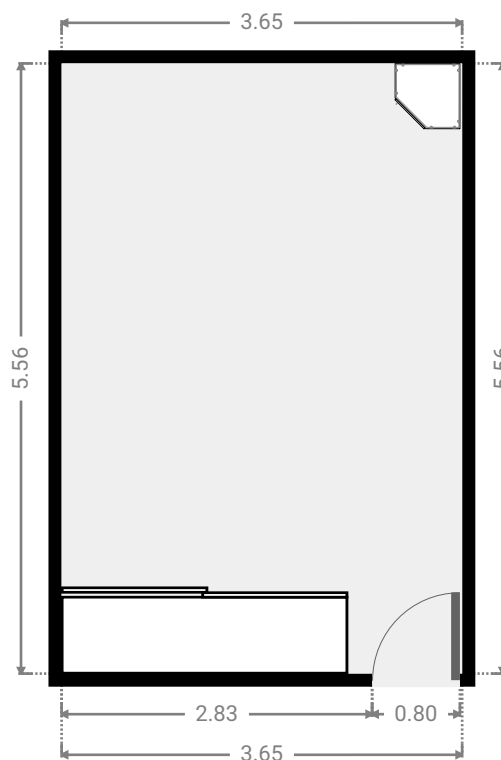
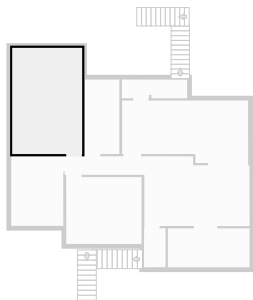

▼ **Bedroom**
1st Floor

WIDTH: 2.73 m • LENGTH: 3.64 m
AREA: 9.93 m² • PERIMETER: 12.73 m

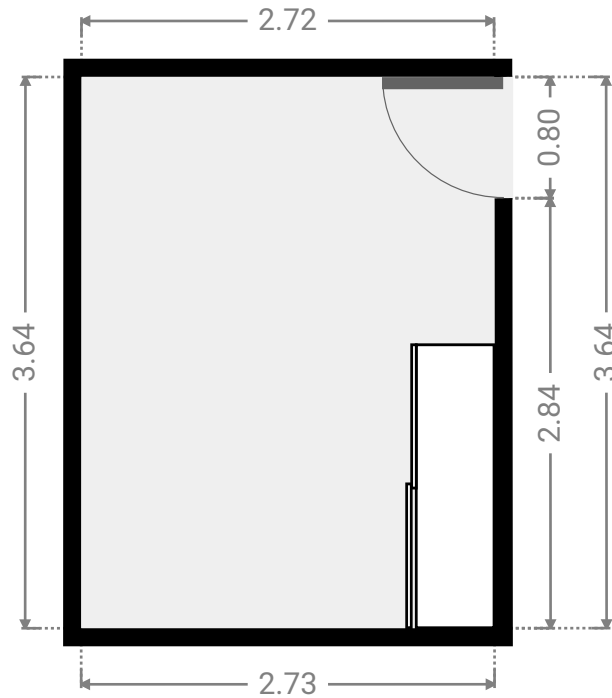
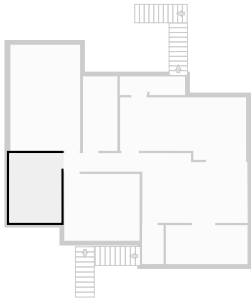

▼ **Bedroom**
1st Floor

WIDTH: 3.95 m • LENGTH: 3.50 m
AREA: 13.80 m² • PERIMETER: 14.89 m

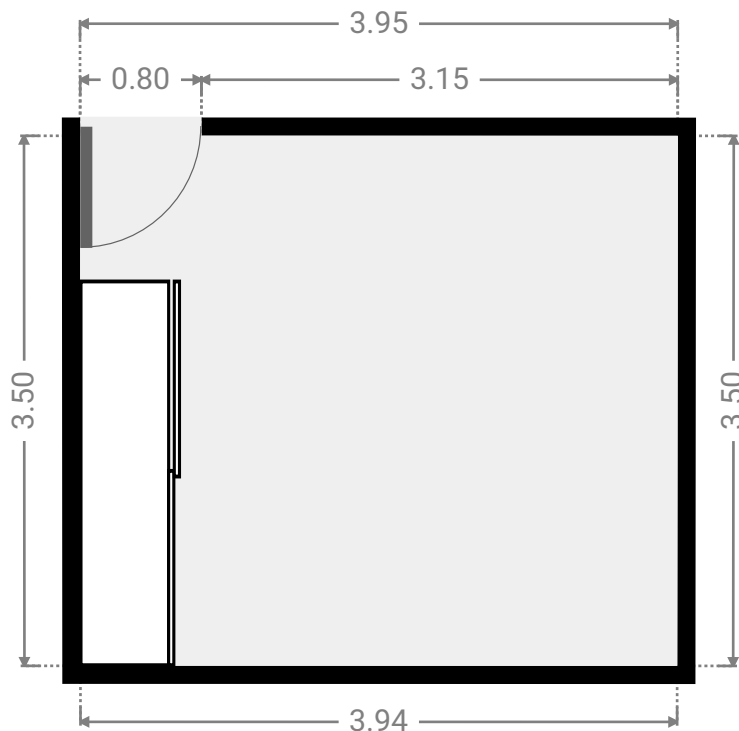
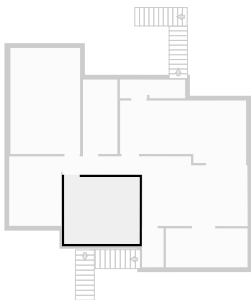

▼ Other
1st Floor

WIDTH: 1.13 m • LENGTH: 2.04 m
AREA: 2.30 m² • PERIMETER: 6.34 m

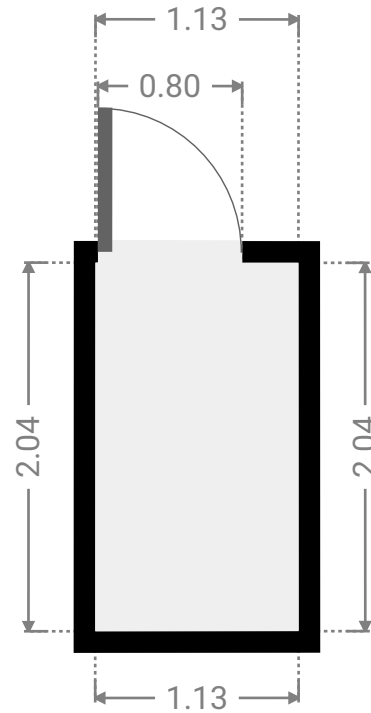
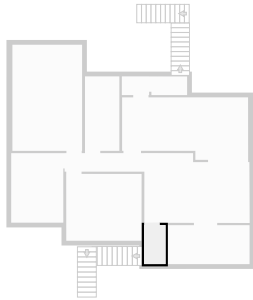

▼ Other
1st Floor

WIDTH: 1.43 m • LENGTH: 0.98 m
AREA: 1.40 m² • PERIMETER: 4.82 m

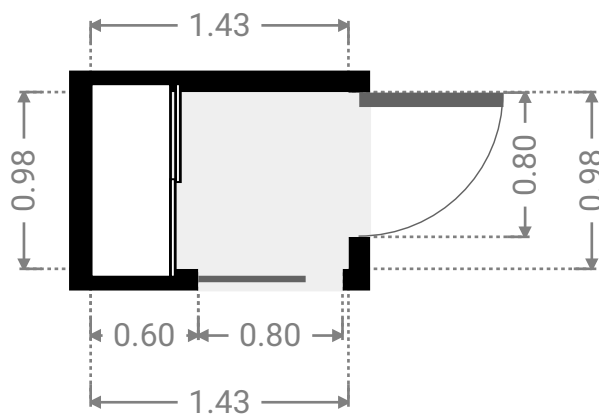
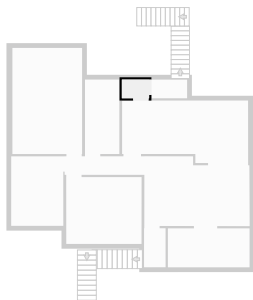

▼ Other
1st Floor

WIDTH: 1.87 m • LENGTH: 0.98 m
AREA: 1.83 m² • PERIMETER: 5.69 m

