

# 384 East Street

**SUBMITTED BY**  
Ray White Rockhampton Casey  
stockers@cqoz.com

---

**CREATED ON**  
2022-12-01

---

**Floors**  
2

---

▼ Ground Floor

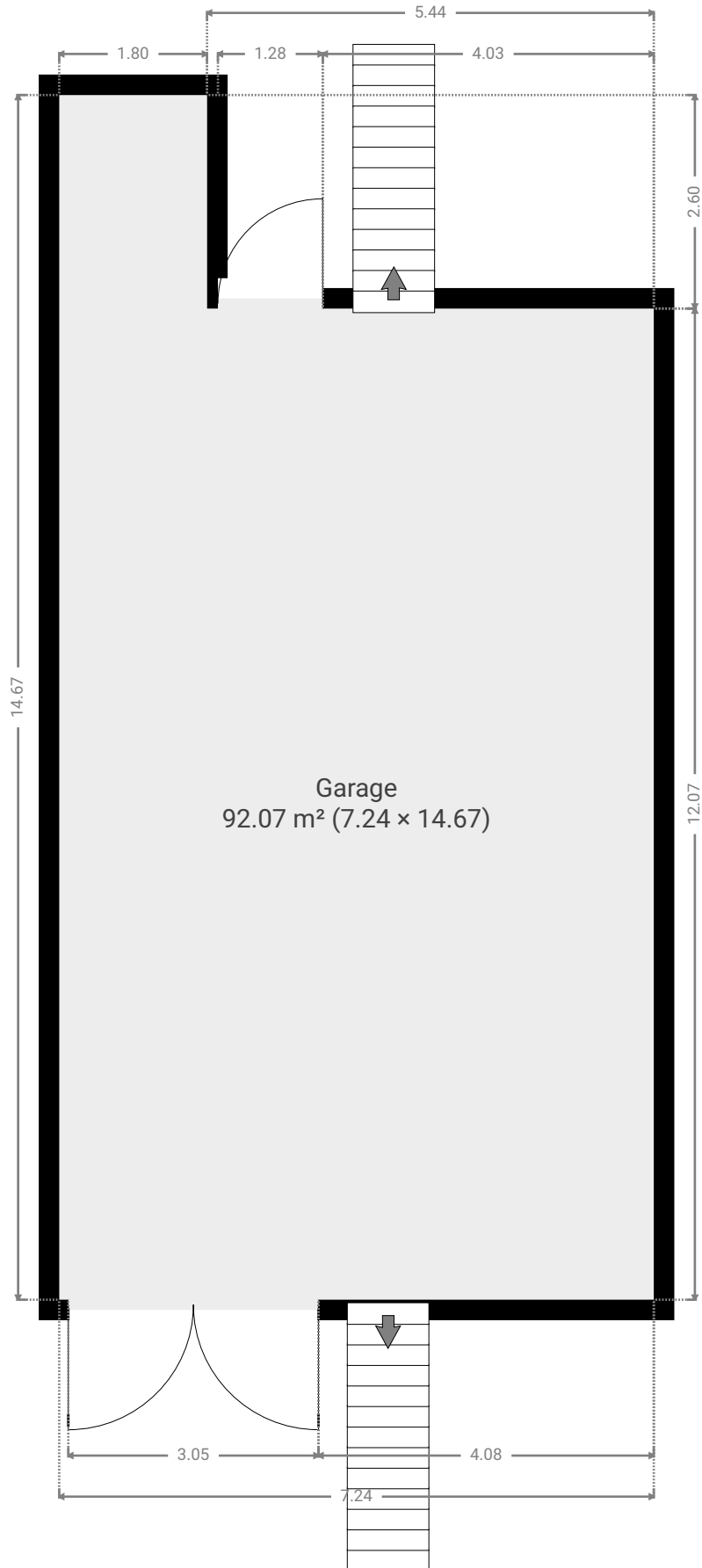

▼ **Garage**  
Ground Floor

WIDTH: 7.24 m • LENGTH: 14.67 m  
AREA: 92.07 m<sup>2</sup> • PERIMETER: 43.82 m

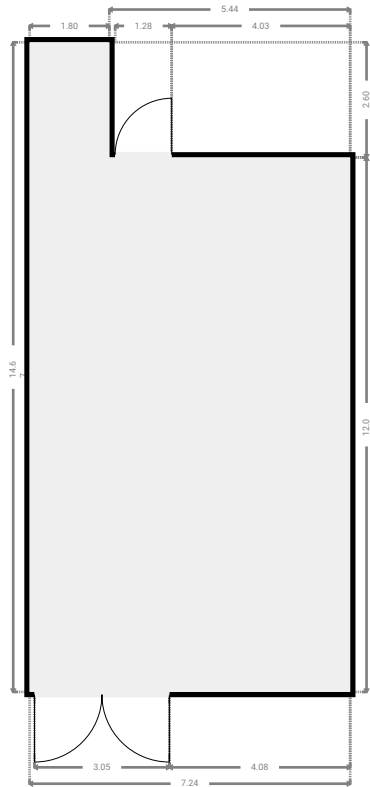

▼ 1st Floor

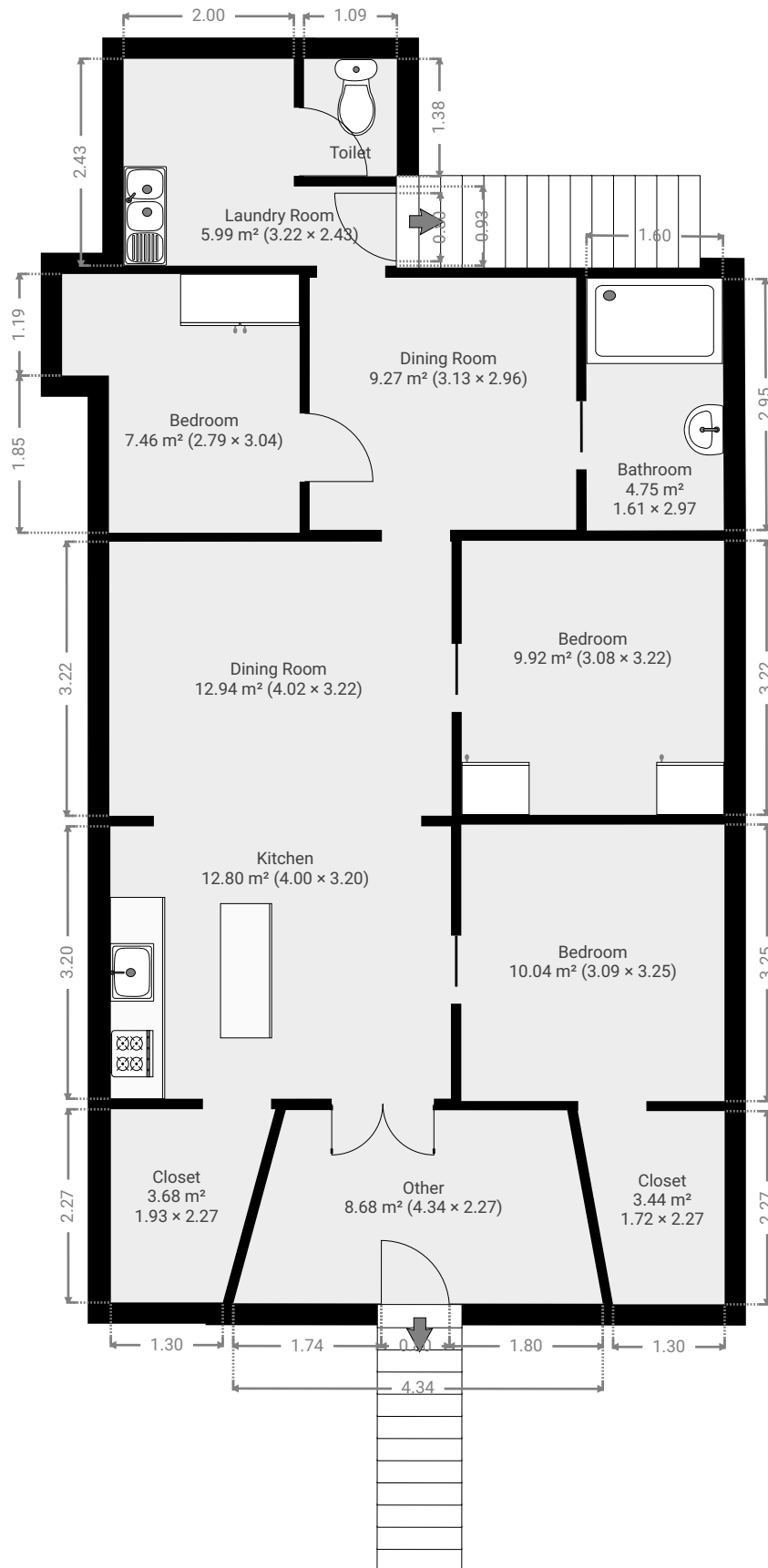

▼ Bathroom  
1st Floor

WIDTH: 1.61 m • LENGTH: 2.97 m  
AREA: 4.75 m<sup>2</sup> • PERIMETER: 9.13 m

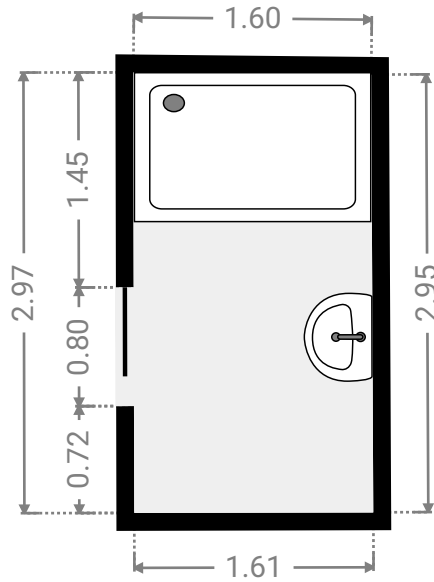
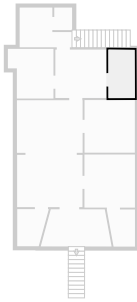

▼ Bedroom  
1st Floor

WIDTH: 3.09 m • LENGTH: 3.25 m  
AREA: 10.04 m<sup>2</sup> • PERIMETER: 12.68 m

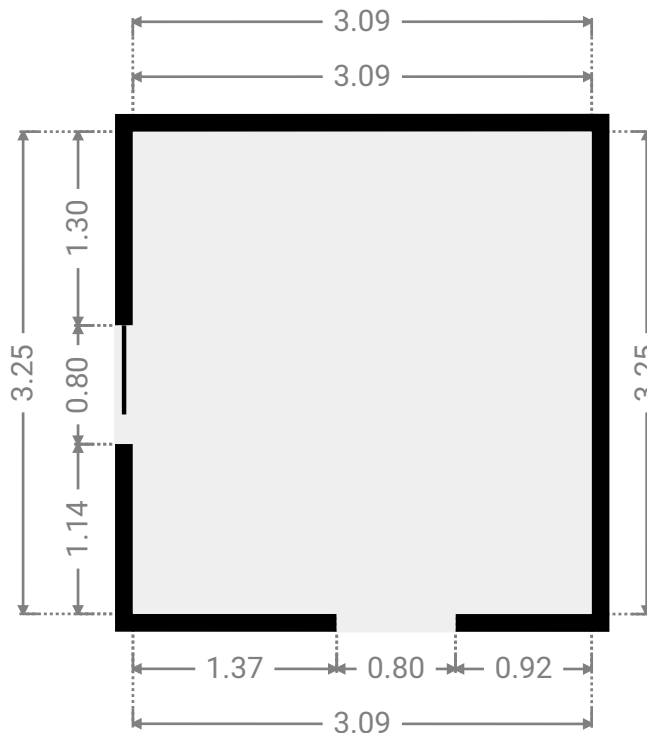
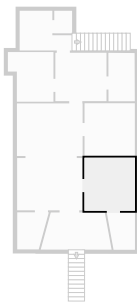

▼ **Closet**  
1st Floor

WIDTH: 1.72 m • LENGTH: 2.27 m  
AREA: 3.44 m<sup>2</sup> • PERIMETER: 7.61 m

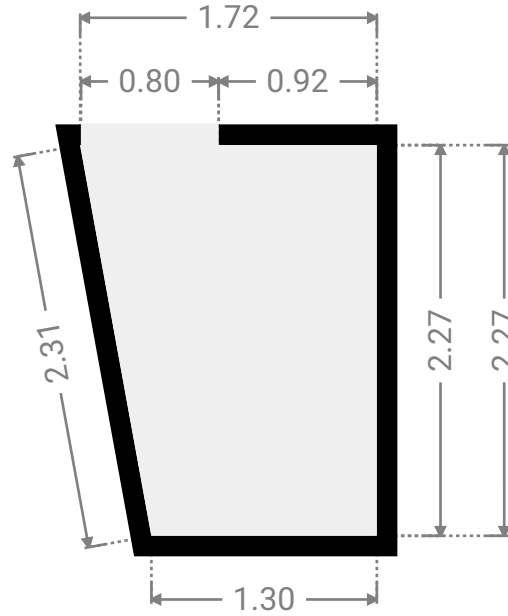
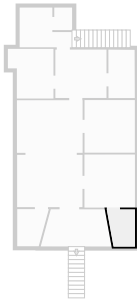

▼ **Bedroom**  
1st Floor

WIDTH: 3.08 m • LENGTH: 3.22 m  
AREA: 9.92 m<sup>2</sup> • PERIMETER: 12.60 m

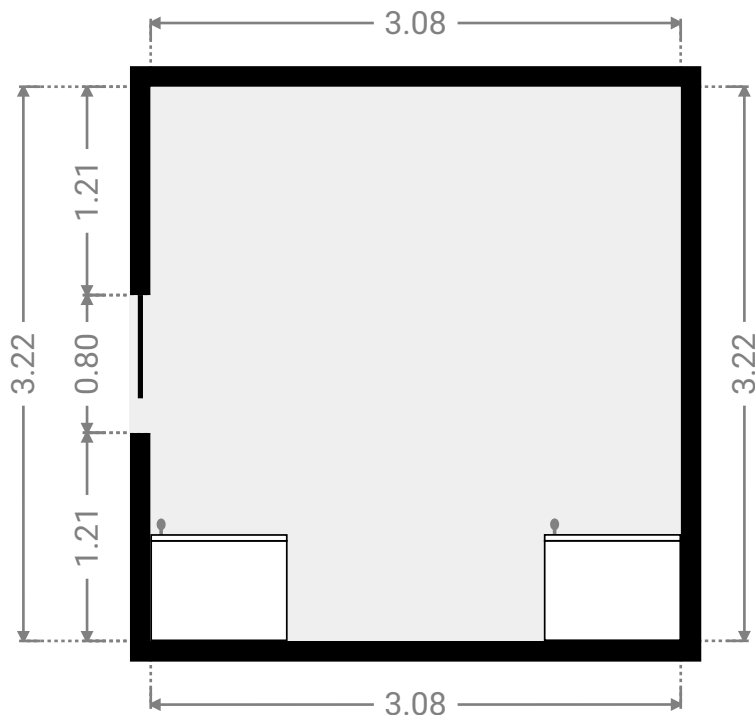
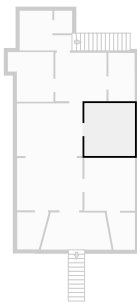

▼ **Bedroom**  
1st Floor

WIDTH: 2.79 m • LENGTH: 3.04 m  
AREA: 7.46 m<sup>2</sup> • PERIMETER: 11.66 m

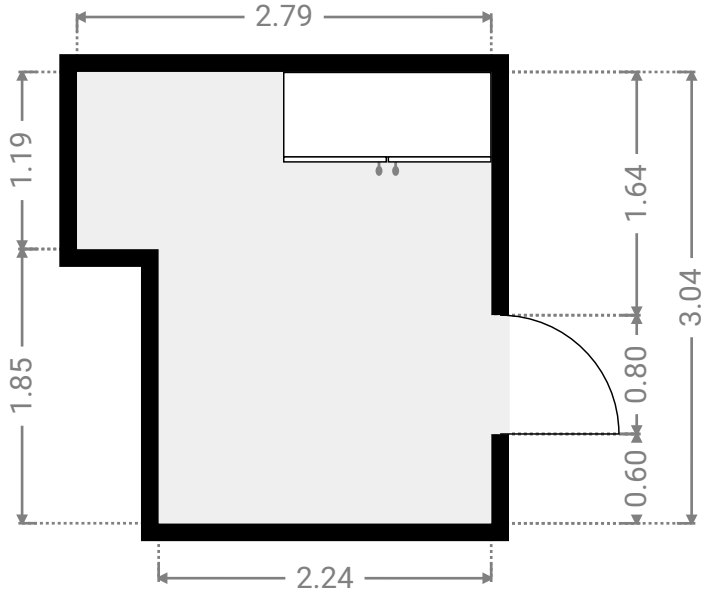
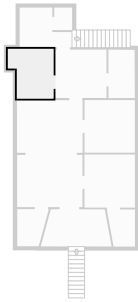

▼ **Dining Room**  
1st Floor

WIDTH: 4.02 m • LENGTH: 3.22 m  
AREA: 12.94 m<sup>2</sup> • PERIMETER: 14.48 m

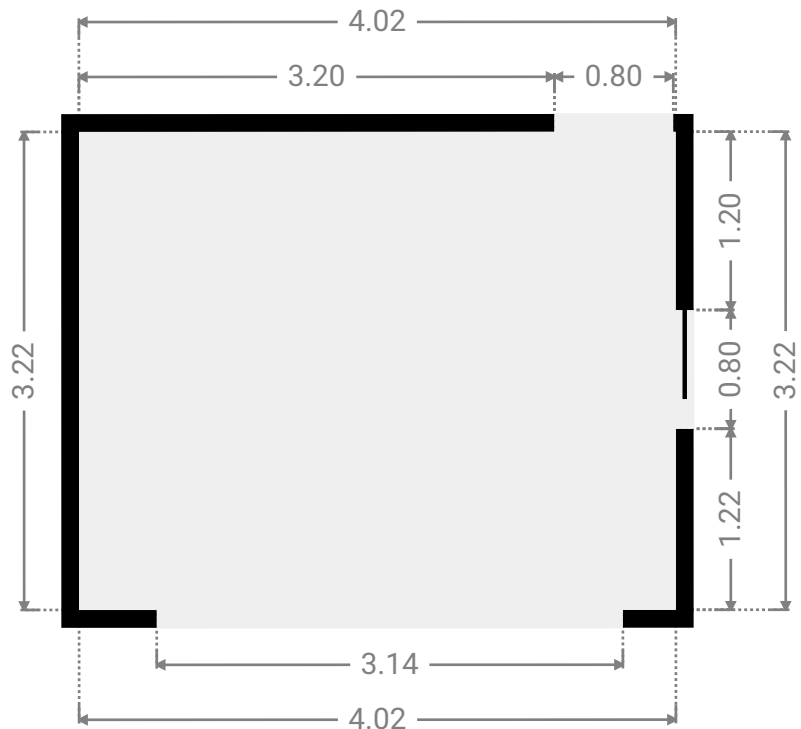
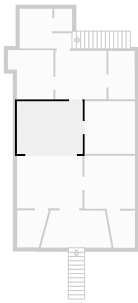

▼ Dining Room  
1st Floor

WIDTH: 3.13 m • LENGTH: 2.96 m  
AREA: 9.27 m<sup>2</sup> • PERIMETER: 12.18 m

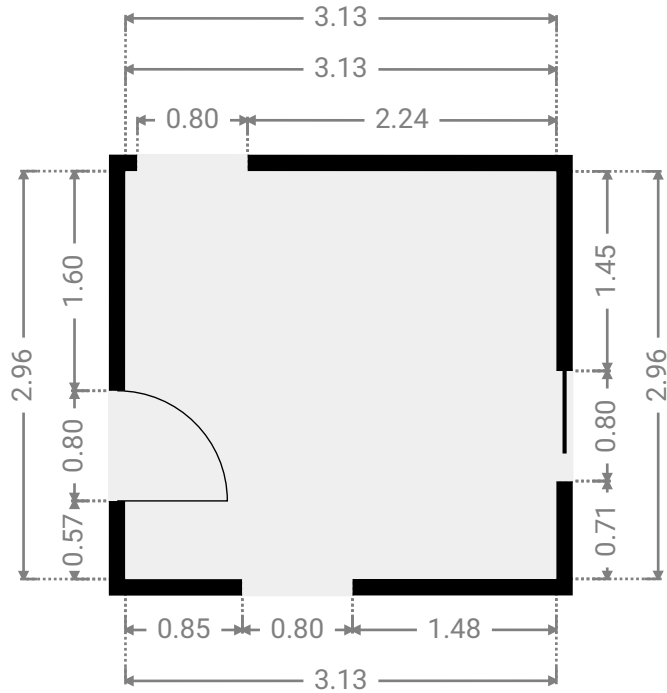
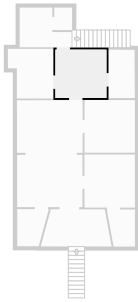

▼ Kitchen  
1st Floor

WIDTH: 4.00 m • LENGTH: 3.20 m  
AREA: 12.80 m<sup>2</sup> • PERIMETER: 14.40 m

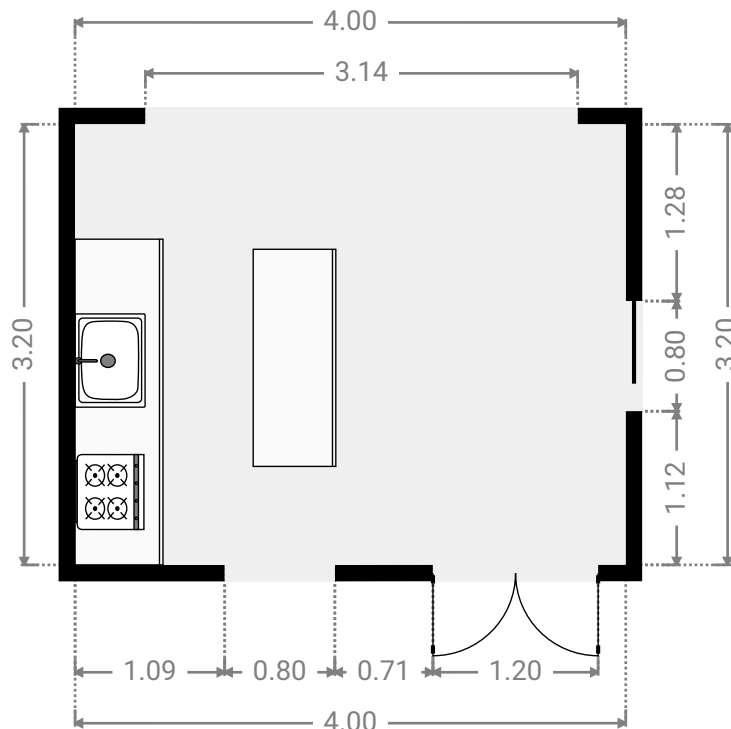
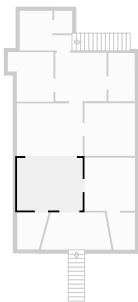



▼ **Closet**  
1st Floor

WIDTH: 1.93 m • LENGTH: 2.27 m  
AREA: 3.68 m<sup>2</sup> • PERIMETER: 7.87 m

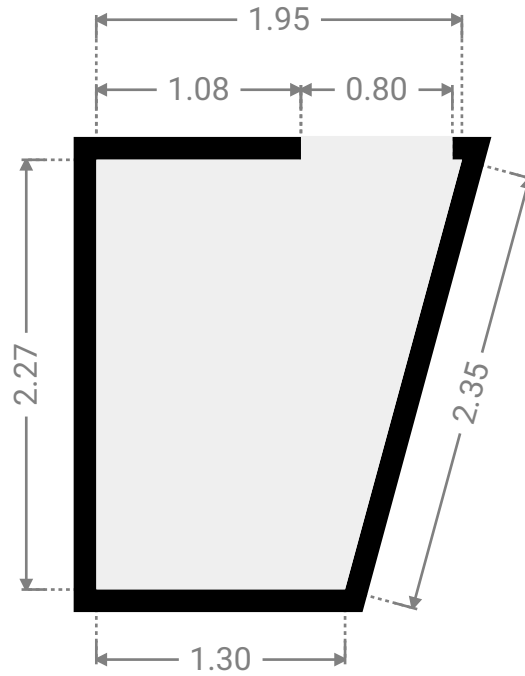
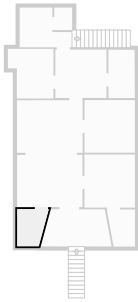

▼ **Laundry Room**  
1st Floor

WIDTH: 3.22 m • LENGTH: 2.43 m  
AREA: 5.99 m<sup>2</sup> • PERIMETER: 11.30 m

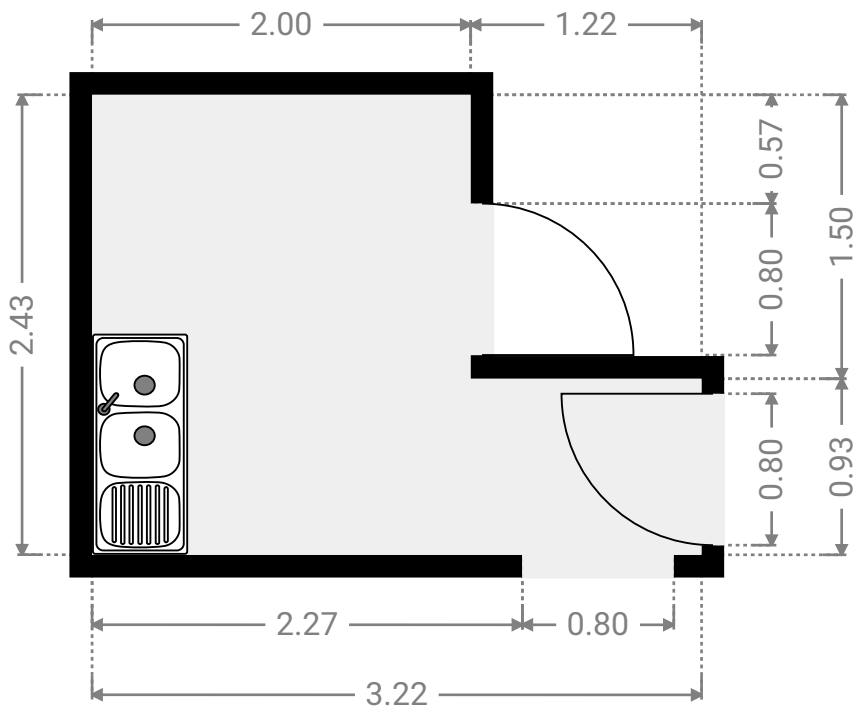
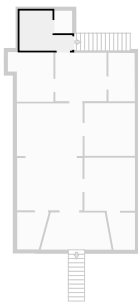

▼ Other  
1st Floor

WIDTH: 4.34 m • LENGTH: 2.27 m  
AREA: 8.68 m<sup>2</sup> • PERIMETER: 12.31 m

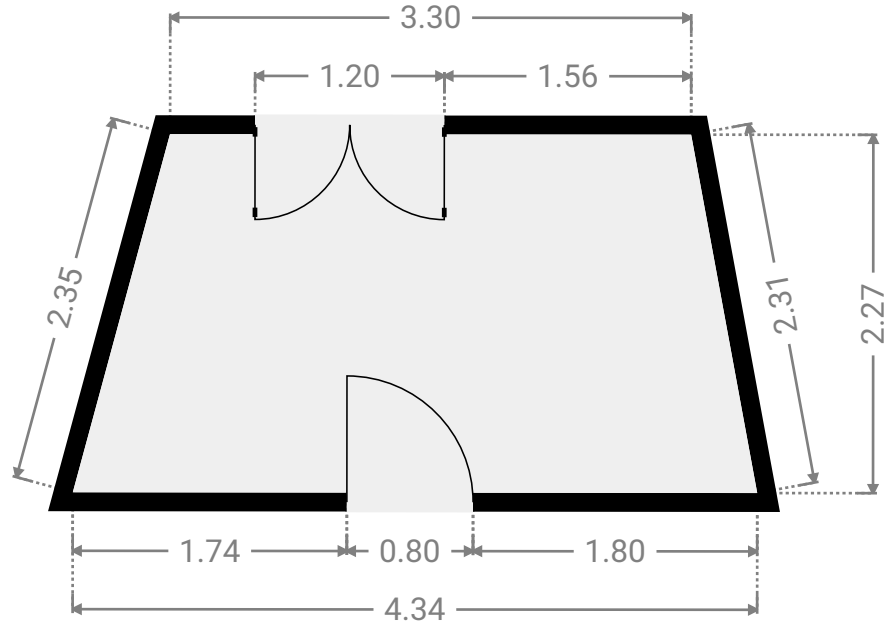
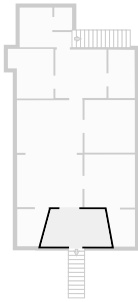

▼ Toilet  
1st Floor

WIDTH: 1.09 m • LENGTH: 1.38 m  
AREA: 1.50 m<sup>2</sup> • PERIMETER: 4.94 m

