

374 Fenlon Avenue

Created on
2020-07-27

Floors

1

▼ Ground Floor

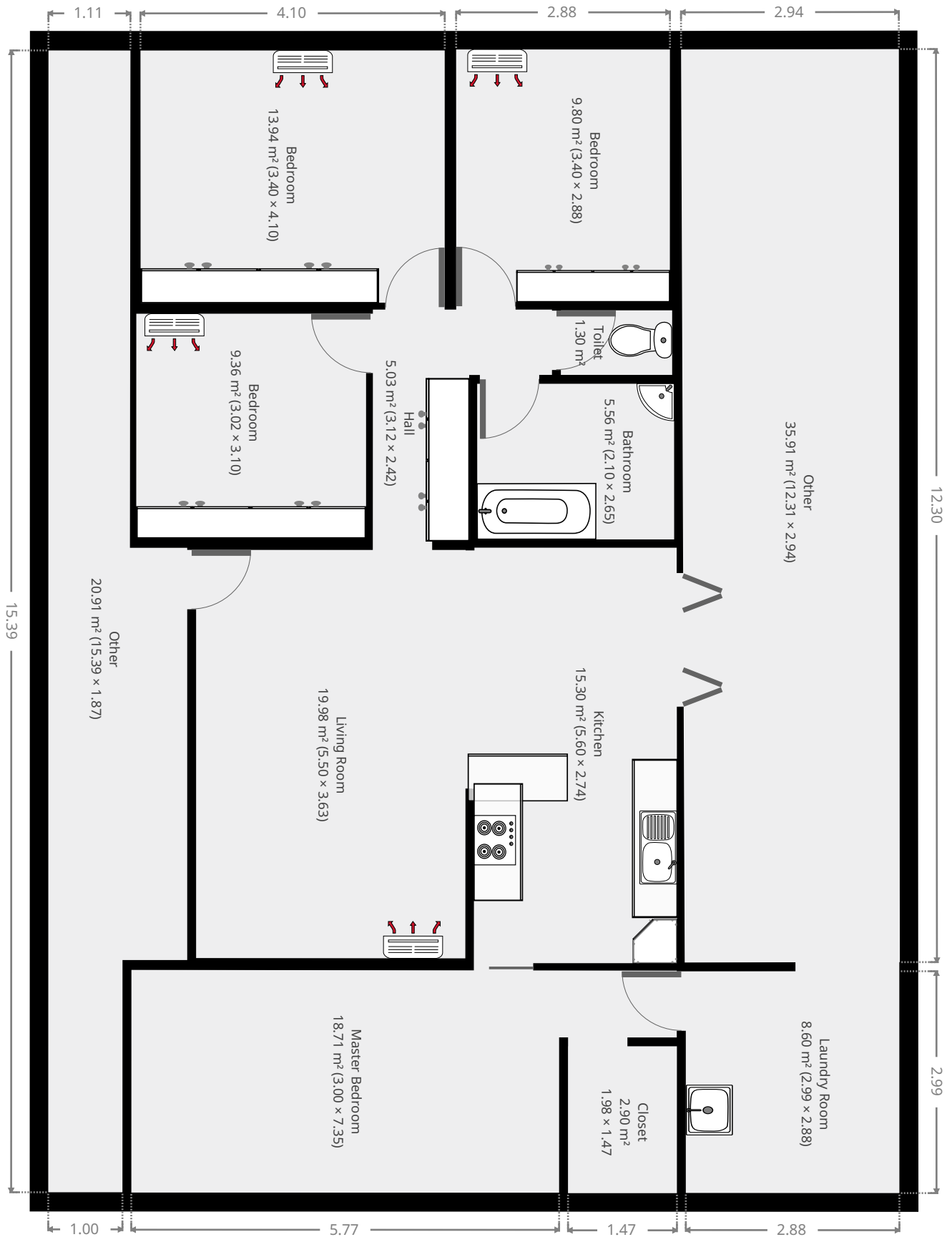

THIS FLOORPLAN IS PROVIDED WITHOUT WARRANTY OF ANY KIND. SENSOPIA DISCLAIMS ANY WARRANTY INCLUDING, WITHOUT LIMITATION, SATISFACTORY QUALITY OR ACCURACY OF DIMENSIONS.

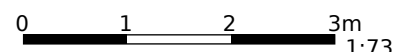

▼ **Living Room**
Ground Floor

WIDTH: 5.50 m • LENGTH: 3.63 m
AREA: 19.98 m² • PERIMETER: 18.27 m

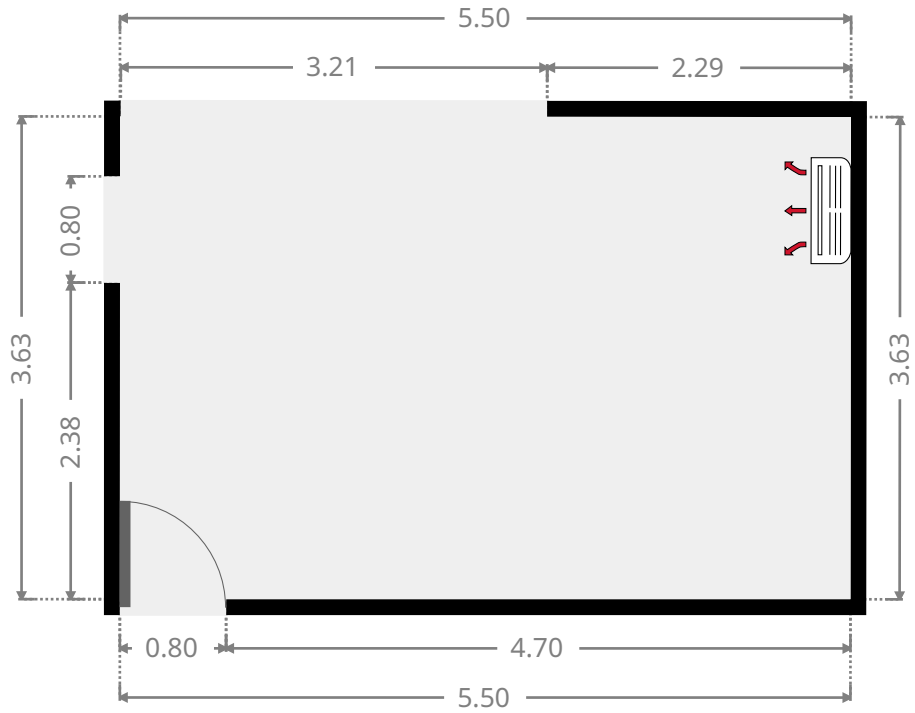
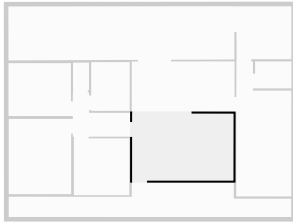

▼ **Kitchen**
Ground Floor

WIDTH: 5.60 m • LENGTH: 2.74 m
AREA: 15.30 m² • PERIMETER: 16.66 m

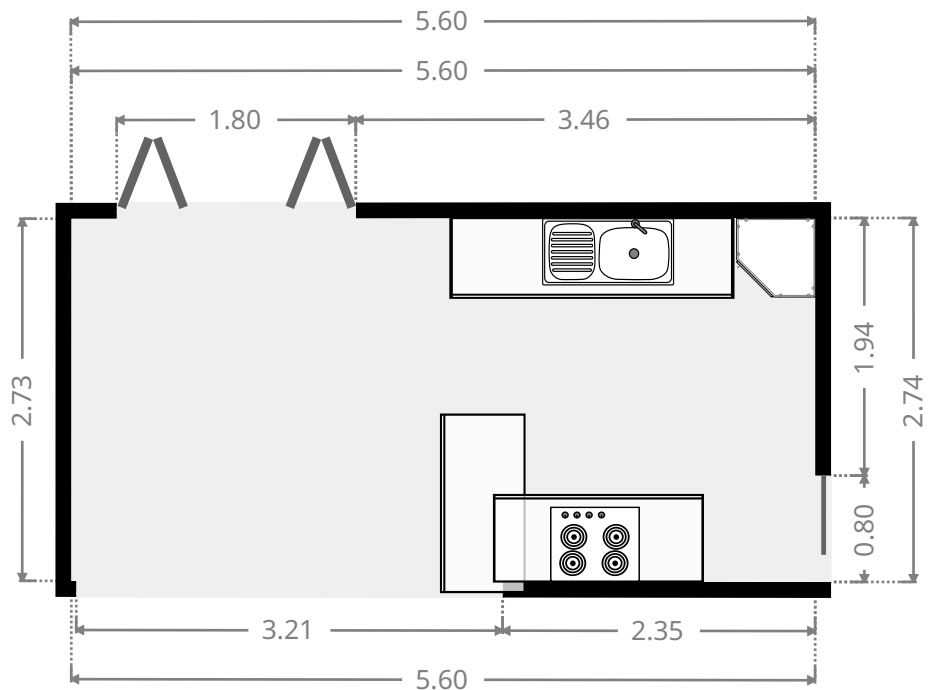
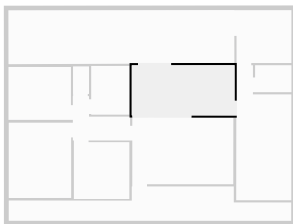

▼ **Master Bedroom**
Ground Floor

WIDTH: 3.00 m • **LENGTH:** 7.35 m
AREA: 18.71 m² • **PERIMETER:** 20.70 m

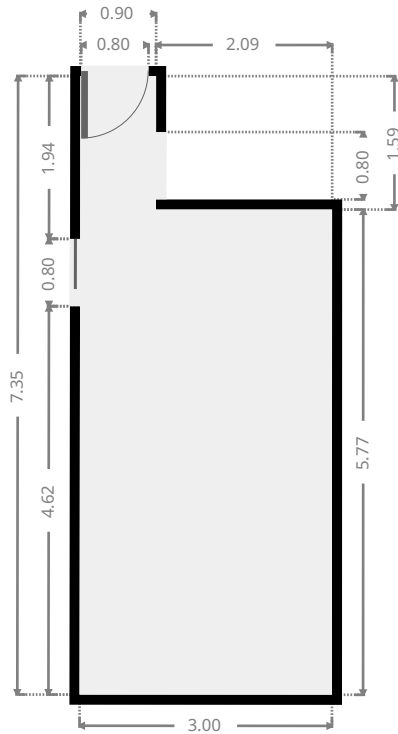
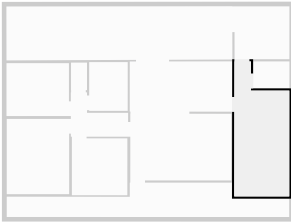

▼ **Closet**
Ground Floor

WIDTH: 1.98 m • **LENGTH:** 1.47 m
AREA: 2.90 m² • **PERIMETER:** 6.89 m

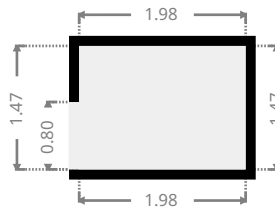
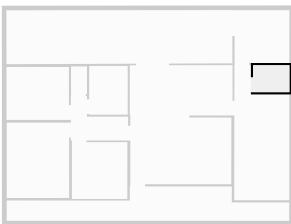

▼ **Hall**
Ground Floor

WIDTH: 3.12 m • LENGTH: 2.42 m
AREA: 5.03 m² • PERIMETER: 11.07 m

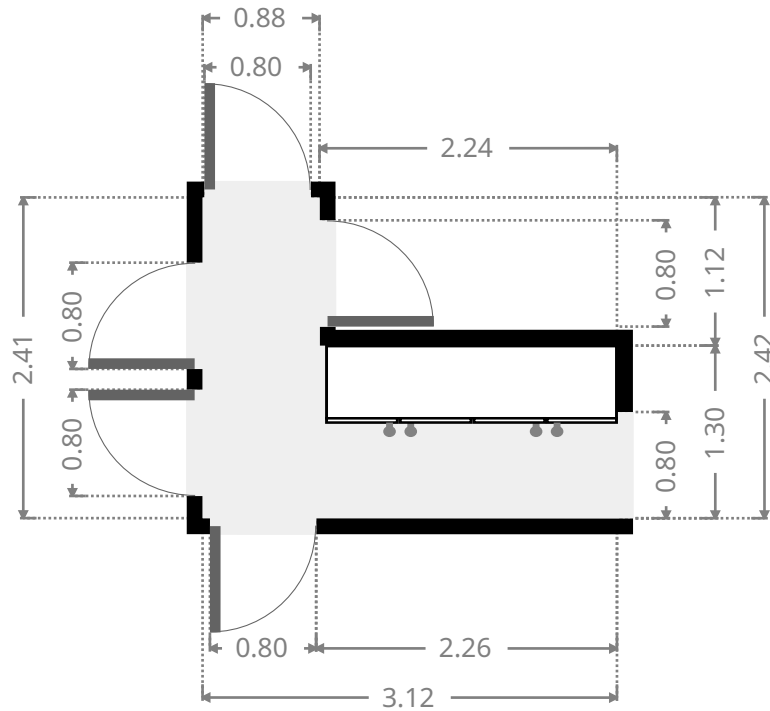
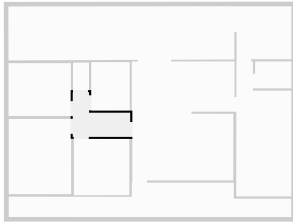

▼ **Bedroom**
Ground Floor

WIDTH: 3.02 m • LENGTH: 3.10 m
AREA: 9.36 m² • PERIMETER: 12.24 m

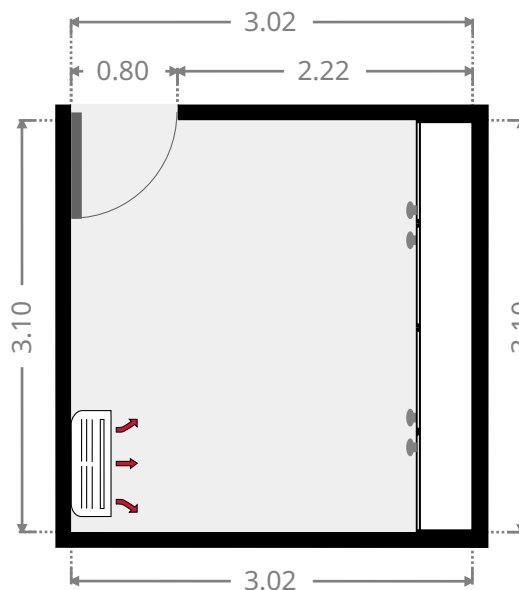
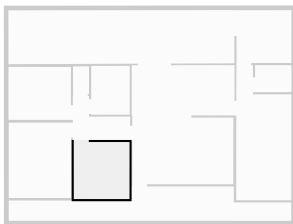

FLOORS: 1

▼ **Bedroom**
Ground Floor

WIDTH: 3.40 m • LENGTH: 4.10 m
AREA: 13.94 m² • PERIMETER: 15.00 m

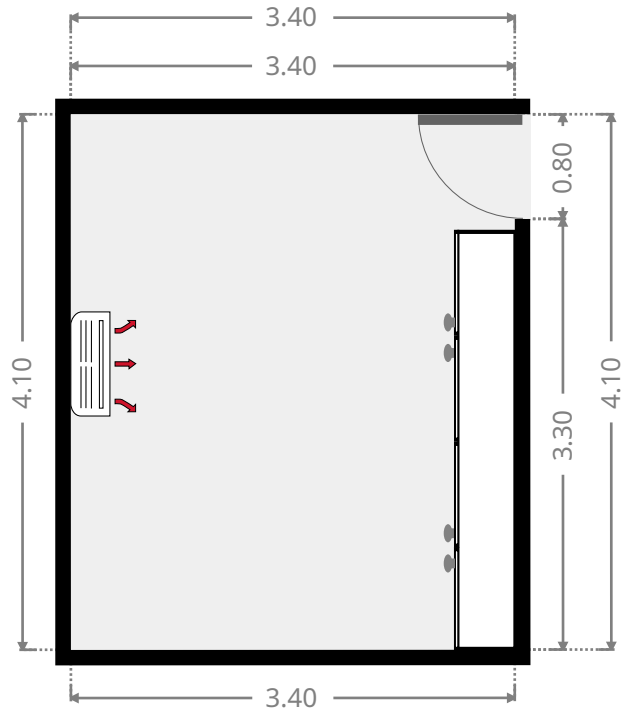
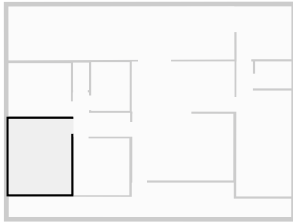

▼ **Bedroom**
Ground Floor

WIDTH: 3.40 m • LENGTH: 2.88 m
AREA: 9.80 m² • PERIMETER: 12.56 m

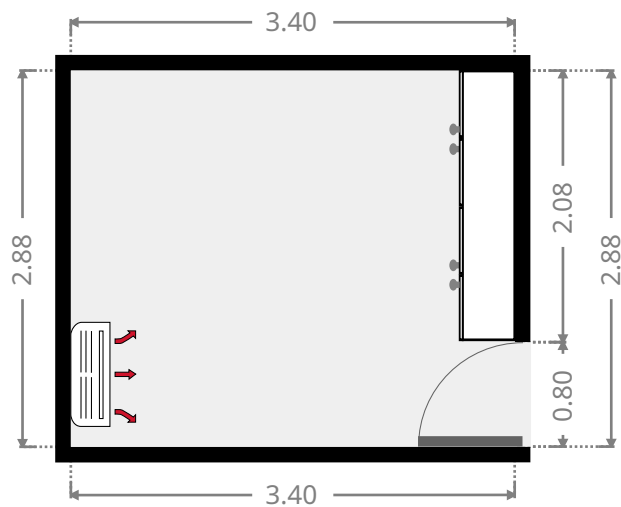
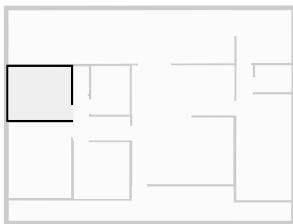

FLOORS: 1

▼ **Toilet**
Ground Floor

WIDTH: 0.87 m • **LENGTH:** 1.50 m
AREA: 1.30 m² • **PERIMETER:** 4.74 m

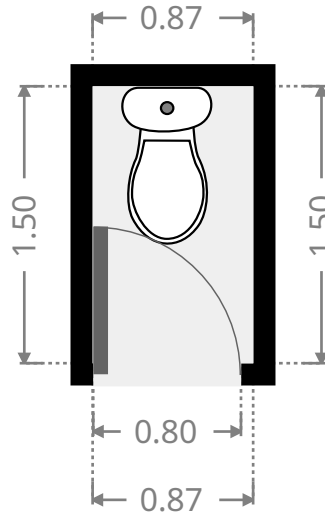
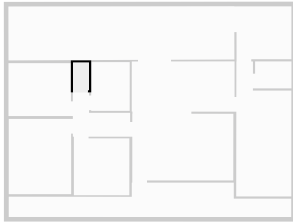

▼ **Bathroom**
Ground Floor

WIDTH: 2.10 m • **LENGTH:** 2.65 m
AREA: 5.56 m² • **PERIMETER:** 9.50 m

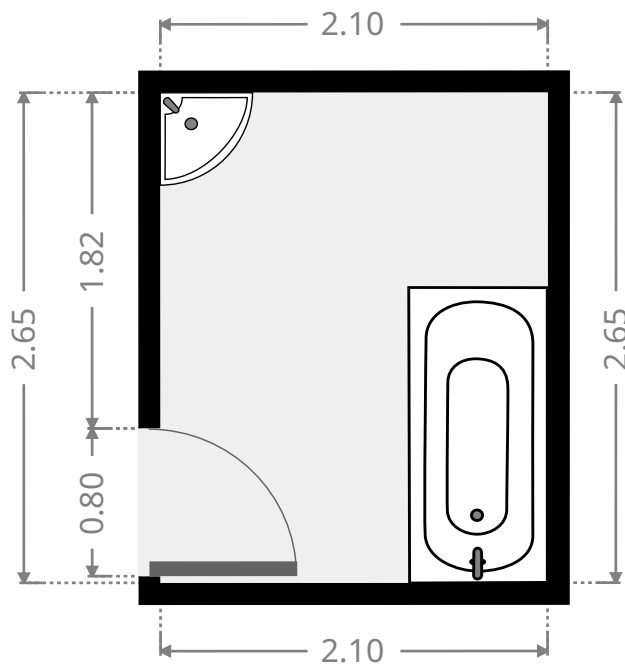
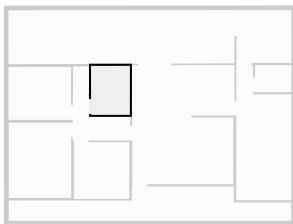

FLOORS: 1

▼ **Other**
Ground Floor

WIDTH: 15.39 m • **LENGTH:** 1.87 m
AREA: 20.91 m² • **PERIMETER:** 34.52 m

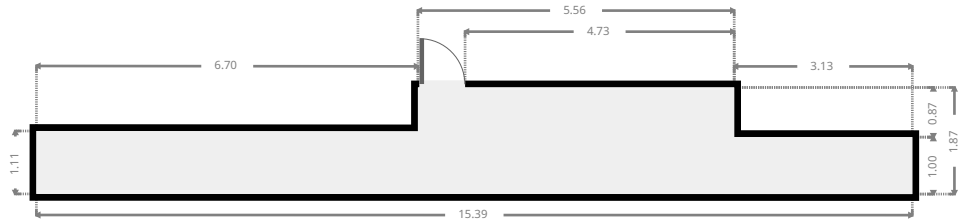

▼ **Other**
Ground Floor

WIDTH: 12.31 m • **LENGTH:** 2.94 m
AREA: 35.91 m² • **PERIMETER:** 30.44 m

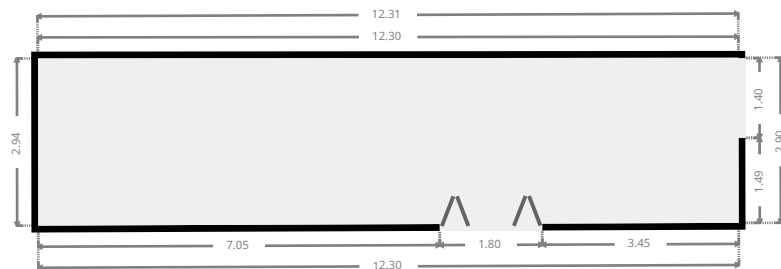
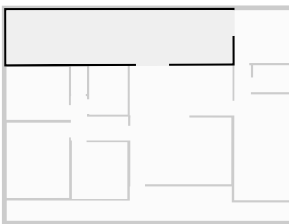

FLOORS: 1

▼ **Laundry Room**
Ground Floor

WIDTH: 2.99 m • LENGTH: 2.88 m
AREA: 8.60 m² • PERIMETER: 11.73 m

