

# 372 Lilly Avenue

Created on  
2018-09-13

Floors  
1

▼ Ground Floor

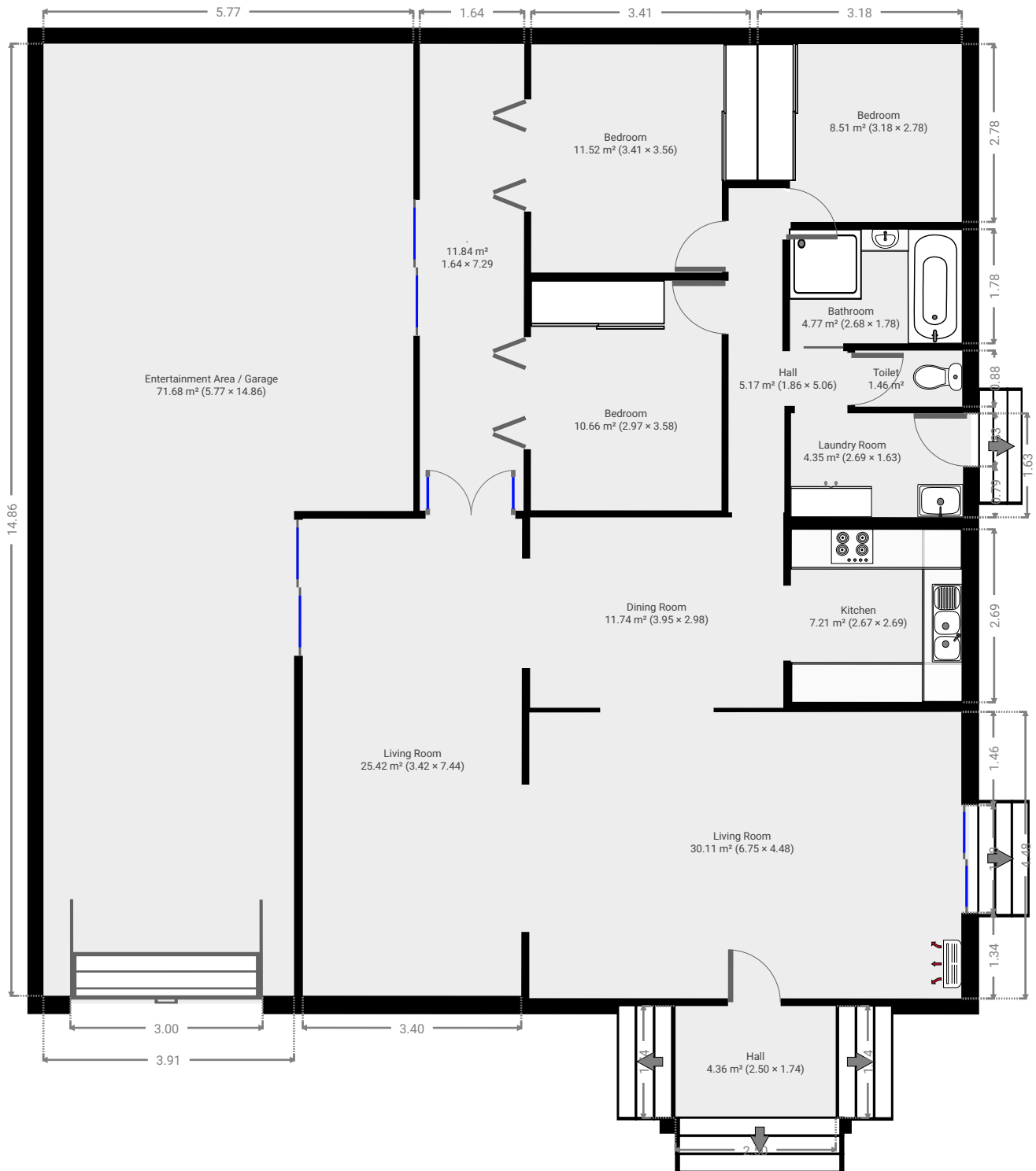

▼ Living Room  
Ground Floor

WIDTH: 6.75 m • LENGTH: 4.48 m  
AREA: 30.11 m<sup>2</sup> • PERIMETER: 22.42 m

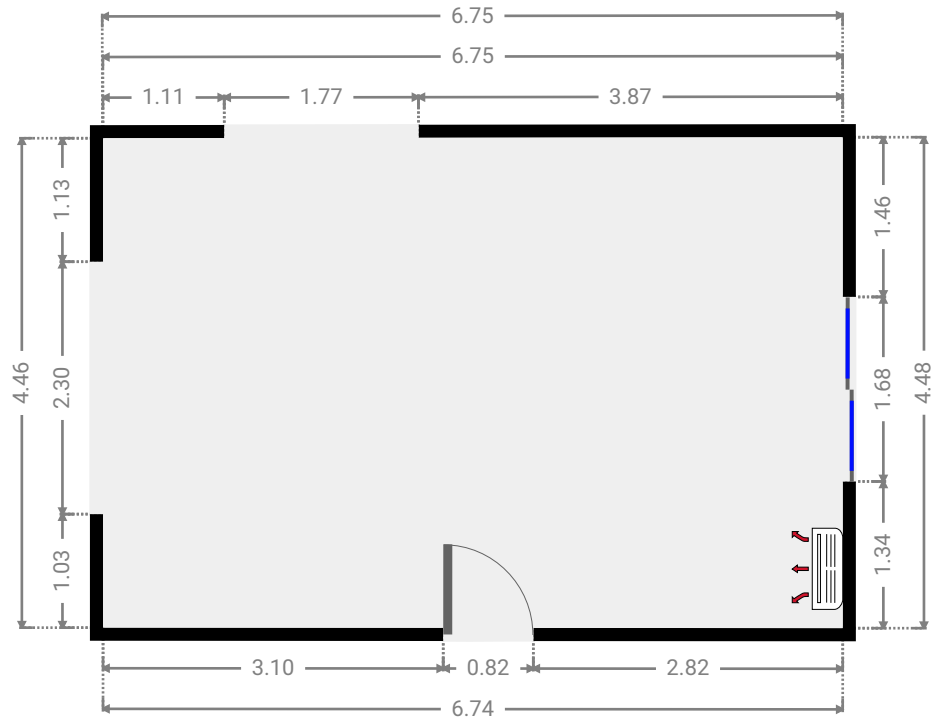
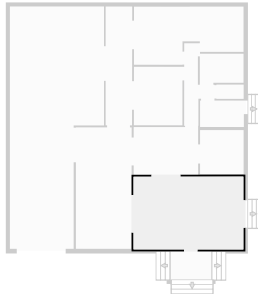

▼ Dining Room  
Ground Floor

WIDTH: 3.95 m • LENGTH: 2.98 m  
AREA: 11.74 m<sup>2</sup> • PERIMETER: 13.84 m

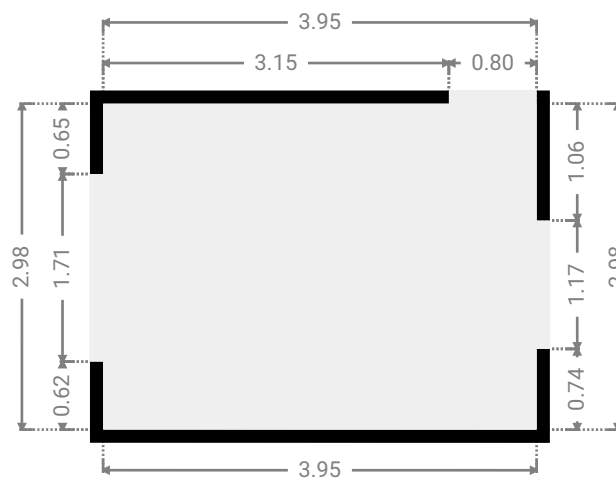
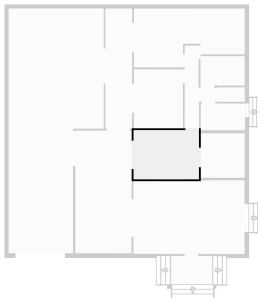

▼ Kitchen  
Ground Floor

WIDTH: 2.67 m • LENGTH: 2.69 m  
AREA: 7.21 m<sup>2</sup> • PERIMETER: 10.74 m

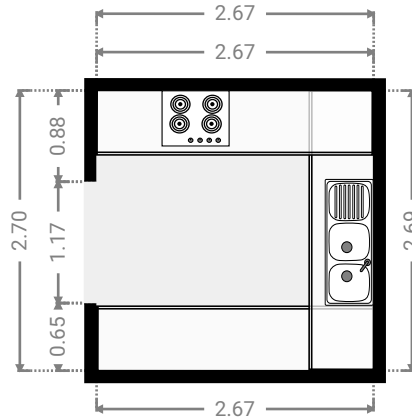
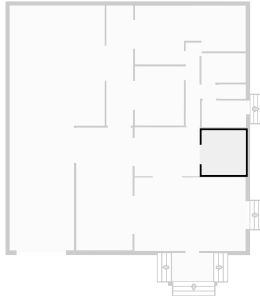

▼ Hall  
Ground Floor

WIDTH: 1.86 m • LENGTH: 5.06 m  
AREA: 5.17 m<sup>2</sup> • PERIMETER: 13.83 m

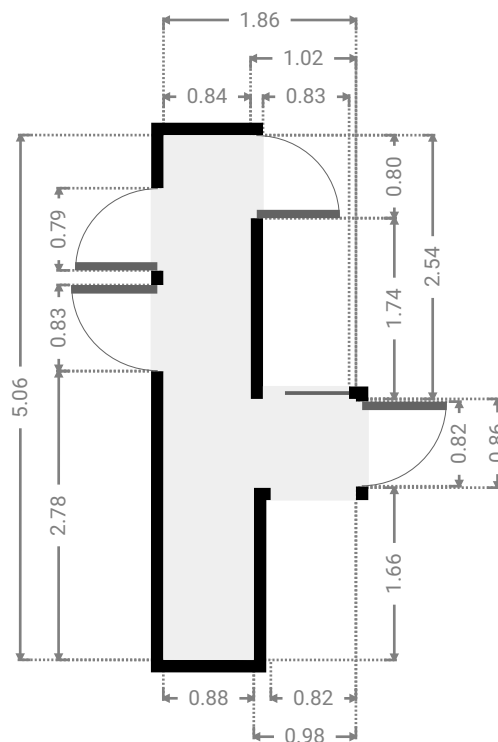

▼ **Laundry Room**  
Ground Floor

WIDTH: 2.69 m • LENGTH: 1.63 m  
AREA: 4.35 m<sup>2</sup> • PERIMETER: 8.61 m

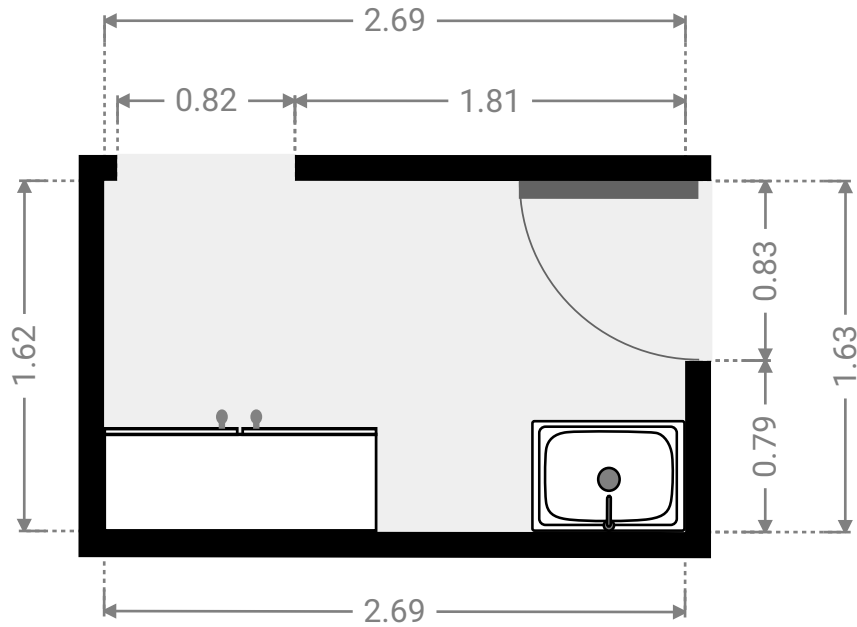
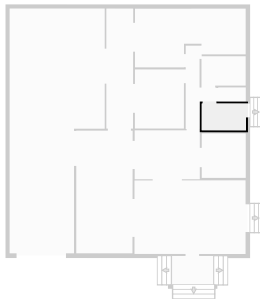

▼ **Toilet**  
Ground Floor

WIDTH: 1.67 m • LENGTH: 0.88 m  
AREA: 1.46 m<sup>2</sup> • PERIMETER: 5.09 m

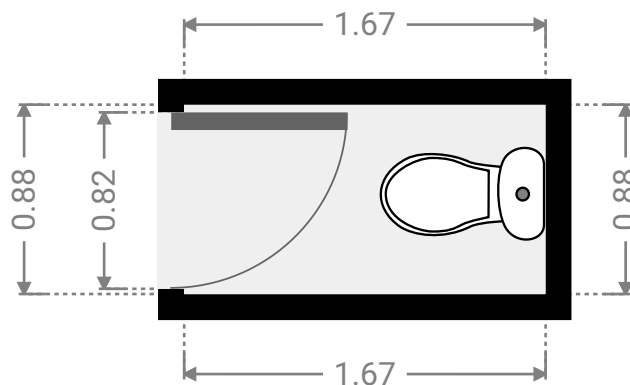
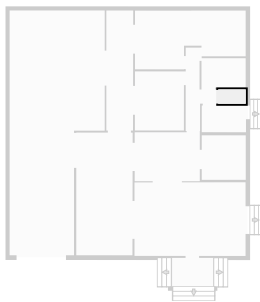

▼ **Bathroom**  
Ground Floor

WIDTH: 2.68 m • LENGTH: 1.78 m  
AREA: 4.77 m<sup>2</sup> • PERIMETER: 8.92 m

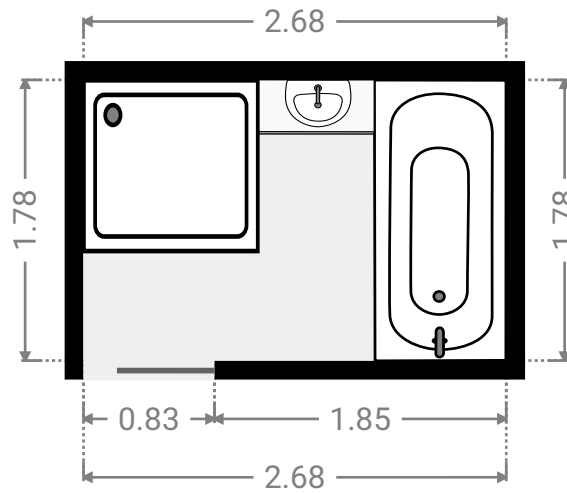
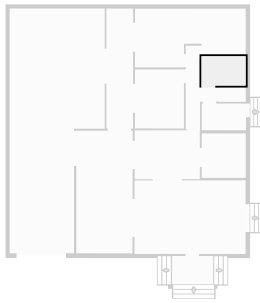

▼ **Bedroom**  
Ground Floor

WIDTH: 2.97 m • LENGTH: 3.58 m  
AREA: 10.66 m<sup>2</sup> • PERIMETER: 13.12 m

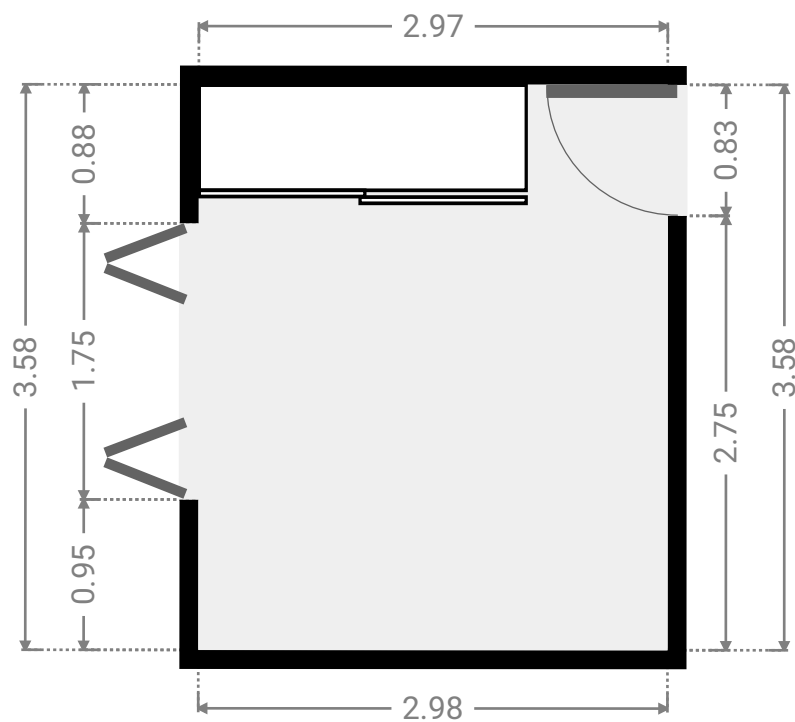
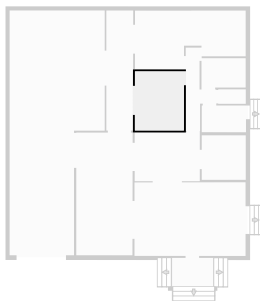

▼ **Bedroom**  
Ground Floor

WIDTH: 3.41 m • LENGTH: 3.56 m  
AREA: 11.52 m<sup>2</sup> • PERIMETER: 13.95 m

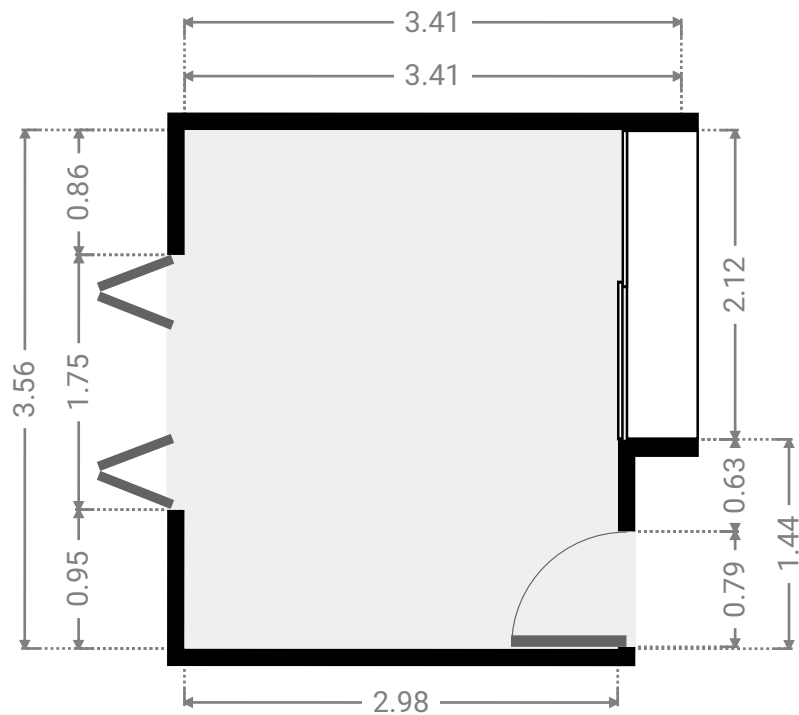
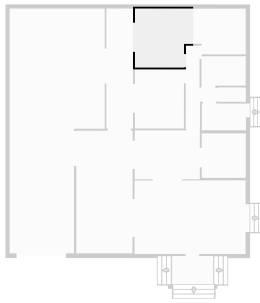

▼ **Bedroom**  
Ground Floor

WIDTH: 3.18 m • LENGTH: 2.78 m  
AREA: 8.51 m<sup>2</sup> • PERIMETER: 11.92 m

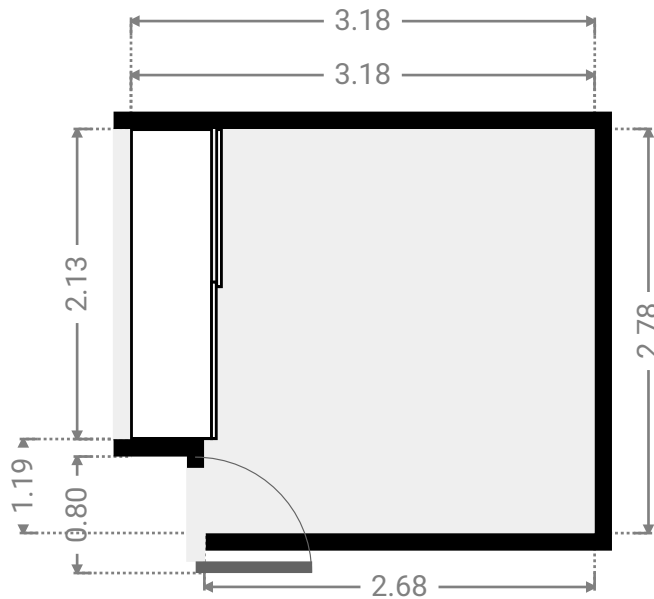
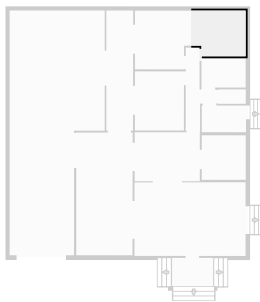

▼ Living Room  
Ground Floor

WIDTH: 3.42 m • LENGTH: 7.44 m  
AREA: 25.42 m<sup>2</sup> • PERIMETER: 21.72 m

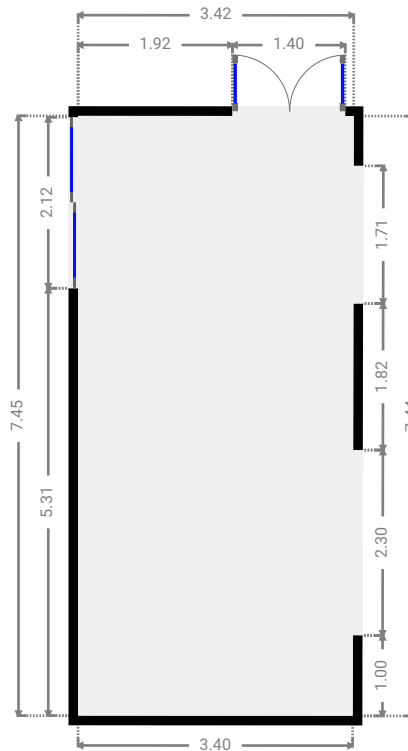
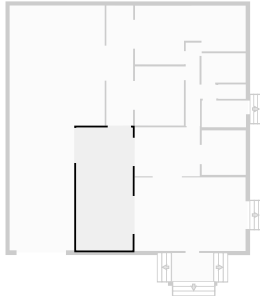

▼ .  
Ground Floor

WIDTH: 1.64 m • LENGTH: 7.29 m  
AREA: 11.84 m<sup>2</sup> • PERIMETER: 17.82 m

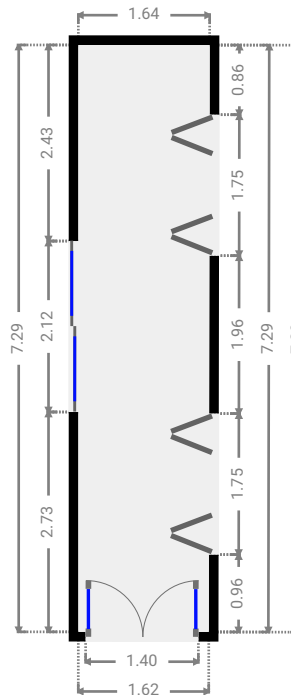
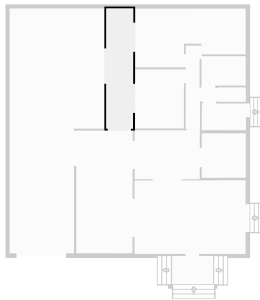



▼ Entertainment Area / Garage  
Ground Floor

WIDTH: 5.77 m • LENGTH: 14.86 m  
AREA: 71.68 m<sup>2</sup> • PERIMETER: 41.26 m

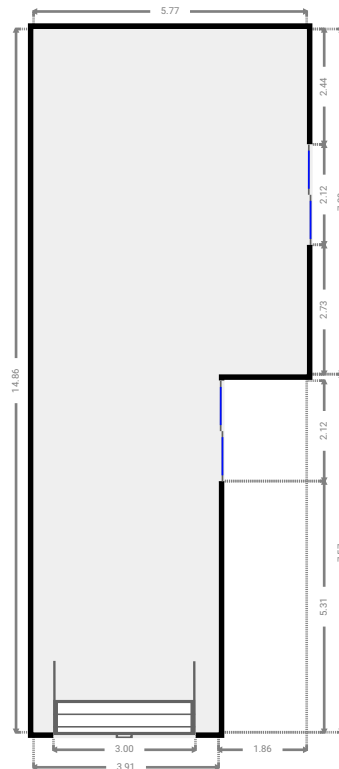
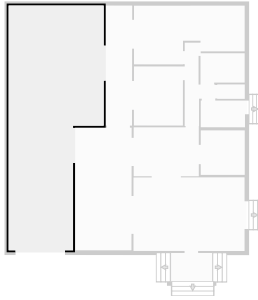

▼ Hall  
Ground Floor

WIDTH: 2.50 m • LENGTH: 1.74 m  
AREA: 4.36 m<sup>2</sup> • PERIMETER: 8.49 m

