

37 Tung Yeen Street

SUBMITTED BY

Ray White Rockhampton Casey
stockers@cqoz.com

CREATED ON

2022-12-12

Floors

4

▼ Ground Floor

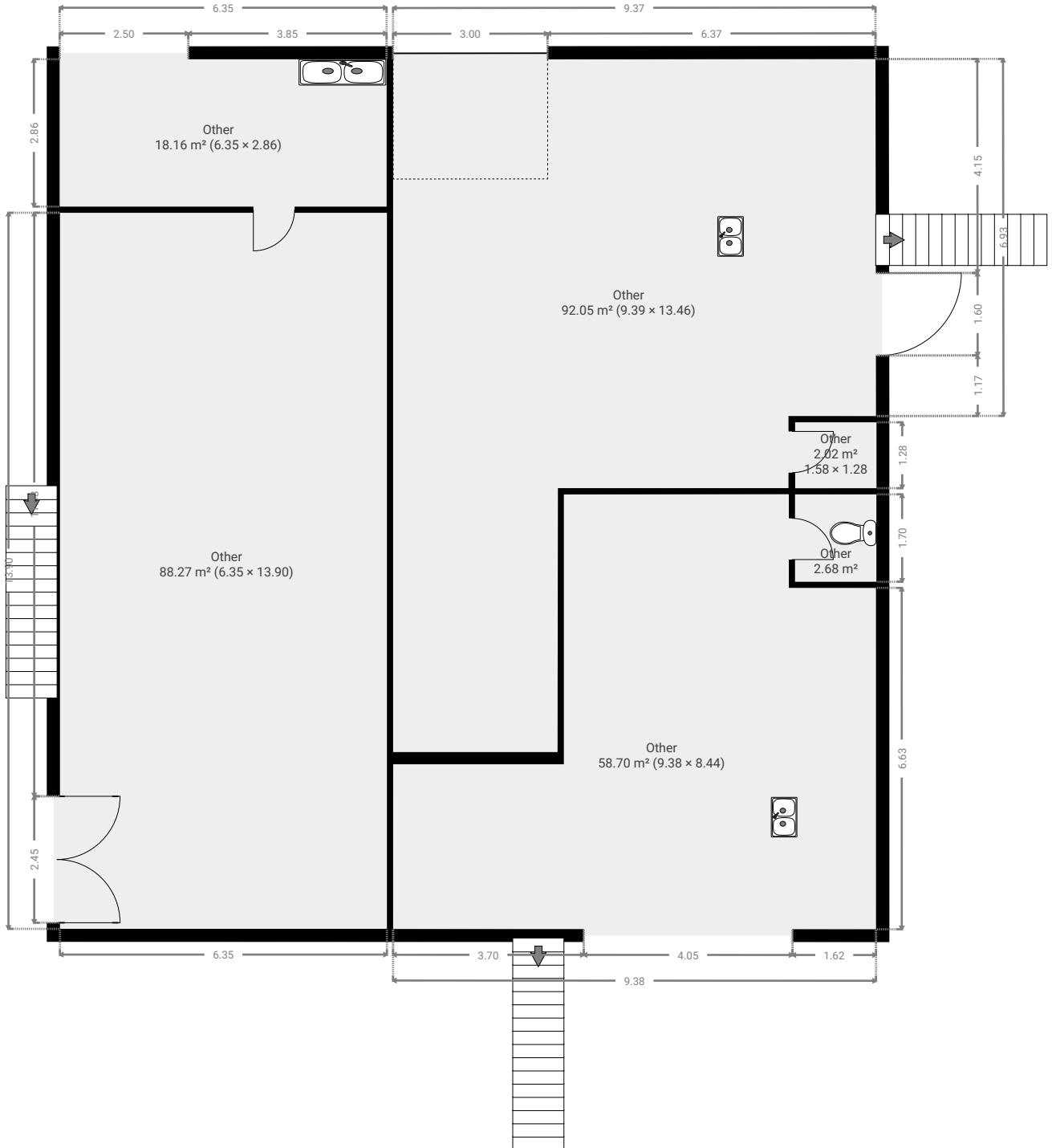

▼ Other Ground Floor

WIDTH: 13.90 m • LENGTH: 6.35 m
AREA: 88.27 m² • PERIMETER: 40.50 m

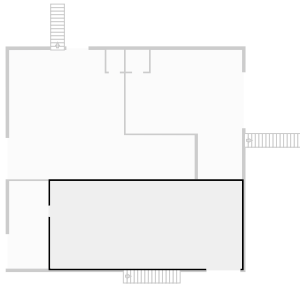

▼ Other Ground Floor

WIDTH: 2.86 m • LENGTH: 6.35 m
AREA: 18.16 m² • PERIMETER: 18.42 m

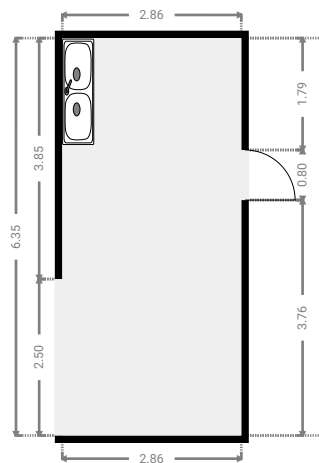
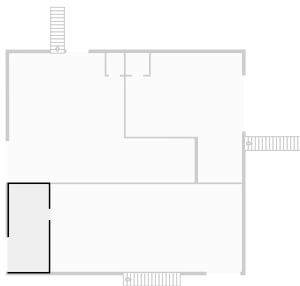

▼ Other Ground Floor

WIDTH: 13.46 m • LENGTH: 9.39 m
AREA: 92.05 m² • PERIMETER: 45.64 m

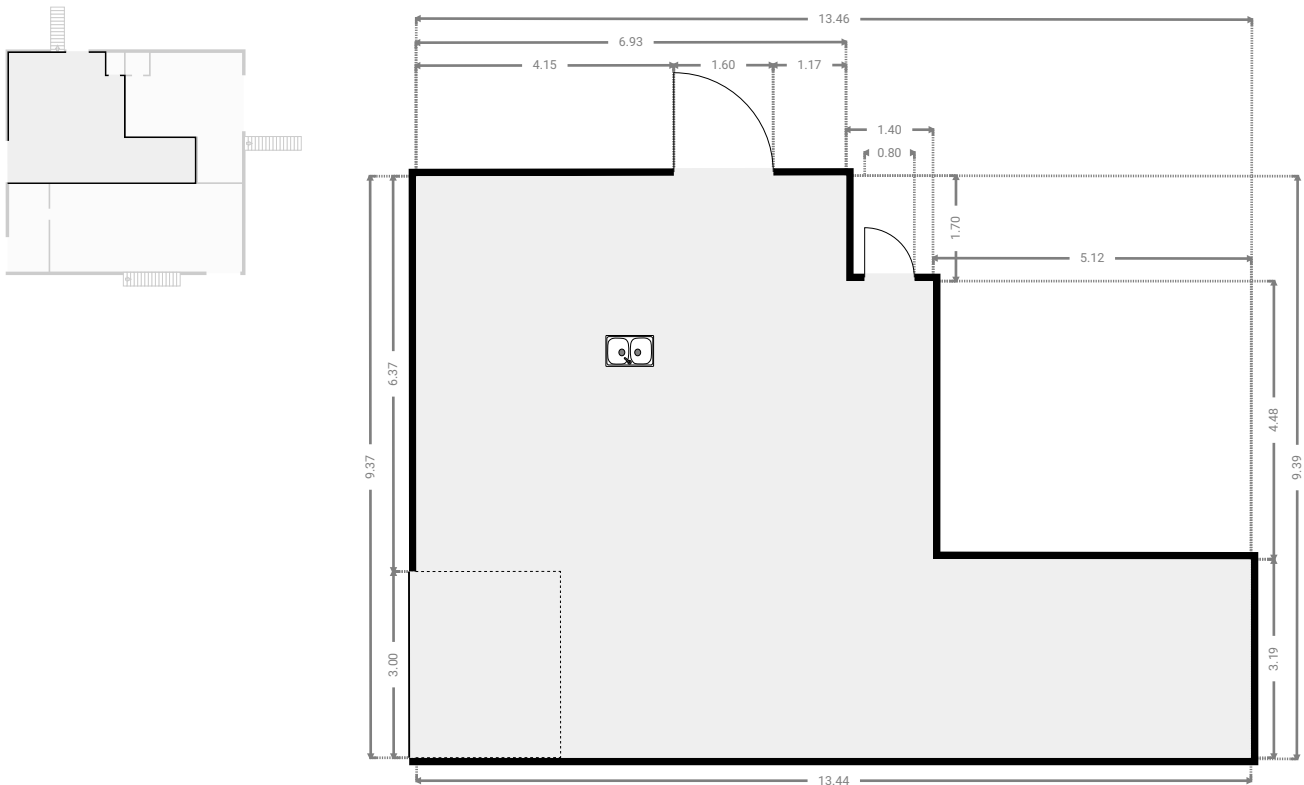

▼ Other Ground Floor

WIDTH: 1.28 m • LENGTH: 1.58 m
AREA: 2.02 m² • PERIMETER: 5.72 m

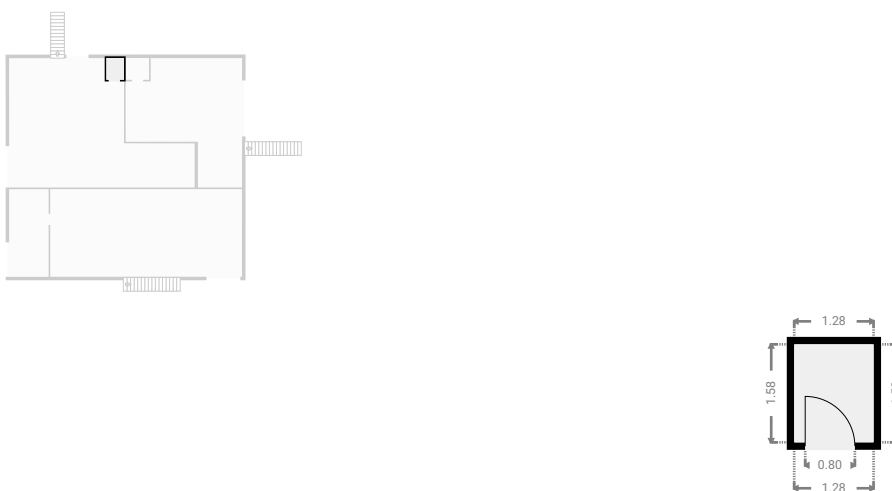

▼ Other Ground Floor

WIDTH: 1.70 m • LENGTH: 1.58 m
AREA: 2.68 m² • PERIMETER: 6.55 m

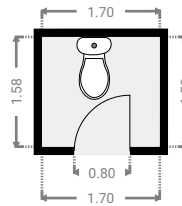
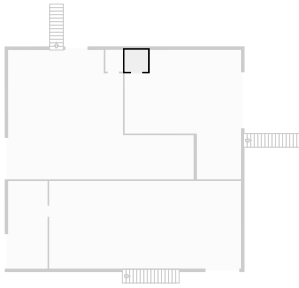

▼ Other Ground Floor

WIDTH: 8.44 m • LENGTH: 9.38 m
AREA: 58.70 m² • PERIMETER: 35.64 m

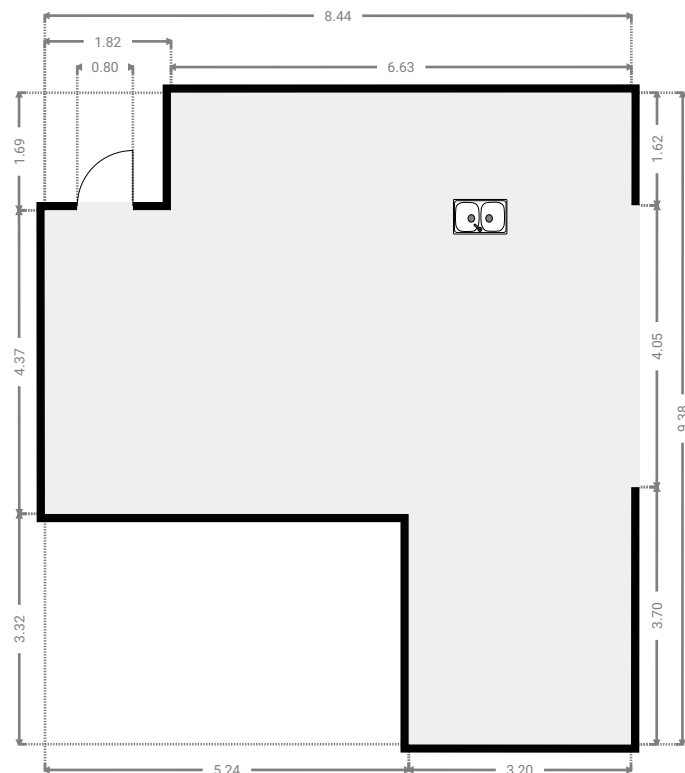
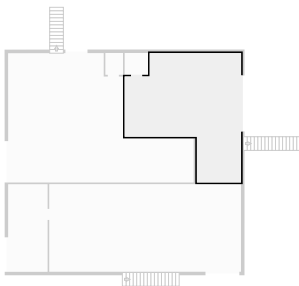

▼ 1st Floor

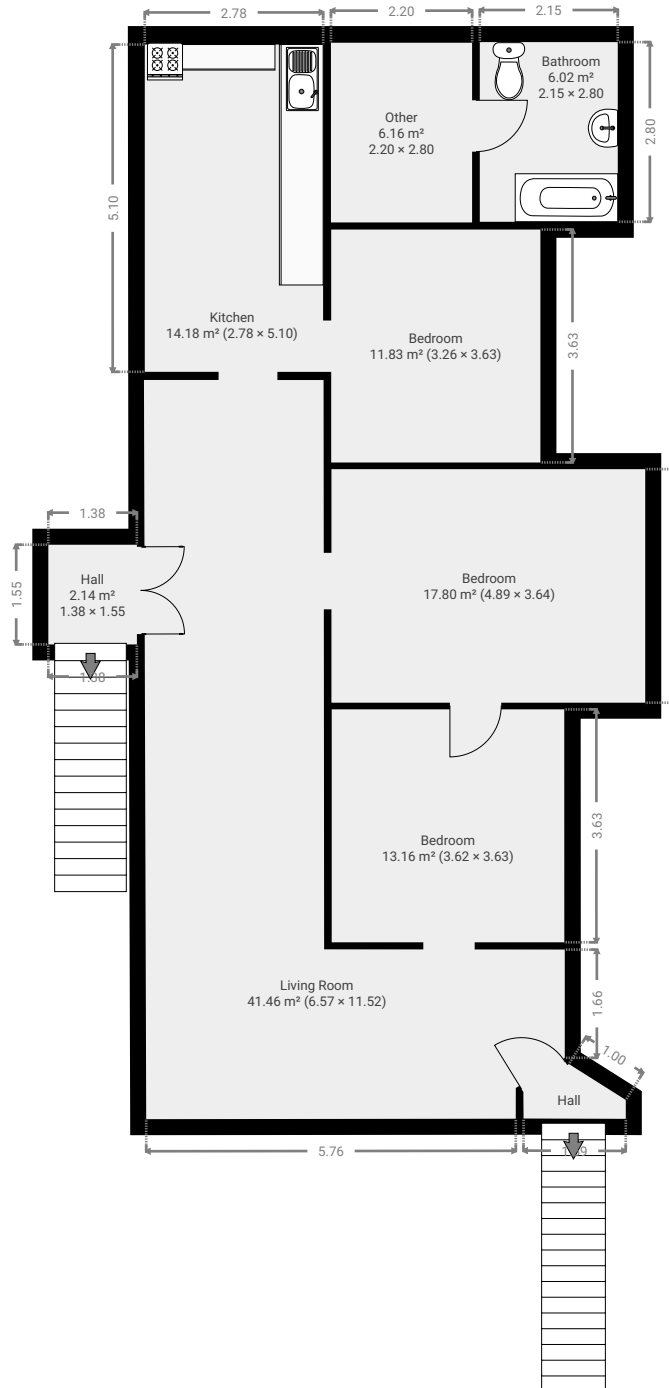

▼ **Bathroom**
1st Floor

WIDTH: 2.80 m • LENGTH: 2.15 m
AREA: 6.02 m² • PERIMETER: 9.90 m

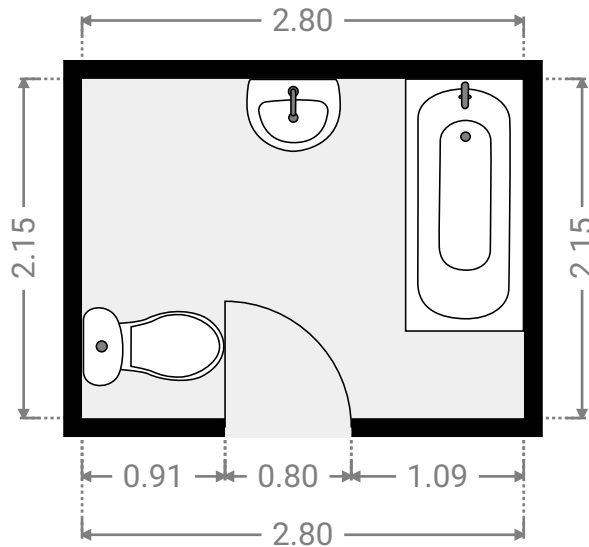
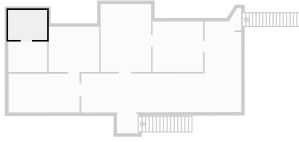

▼ **Bedroom**
1st Floor

WIDTH: 3.63 m • LENGTH: 3.62 m
AREA: 13.16 m² • PERIMETER: 14.51 m

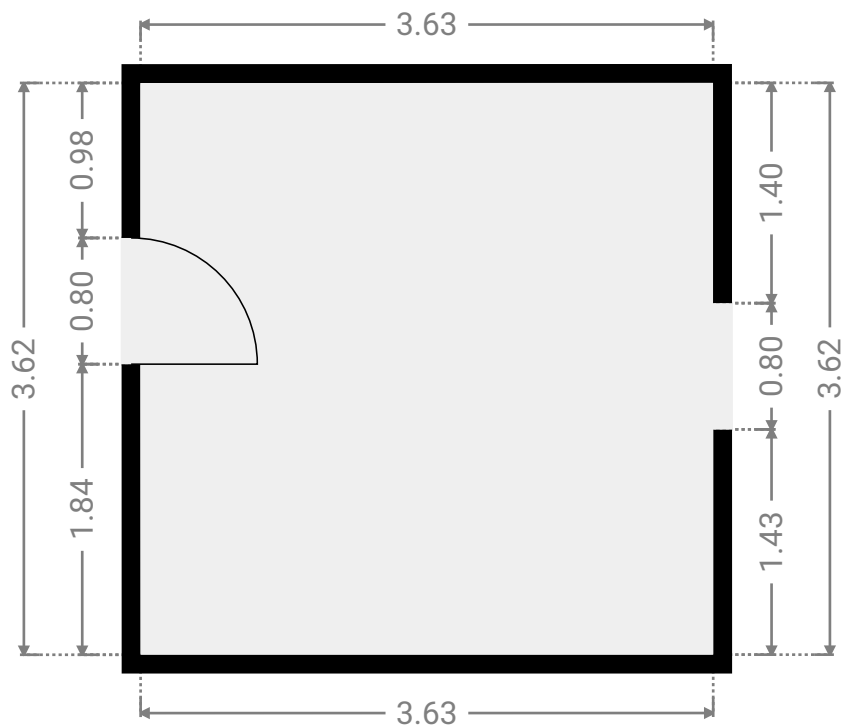
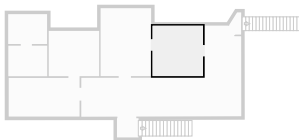

▼ Bedroom 1st Floor

WIDTH: 3.64 m • LENGTH: 4.89 m
AREA: 17.80 m² • PERIMETER: 17.06 m

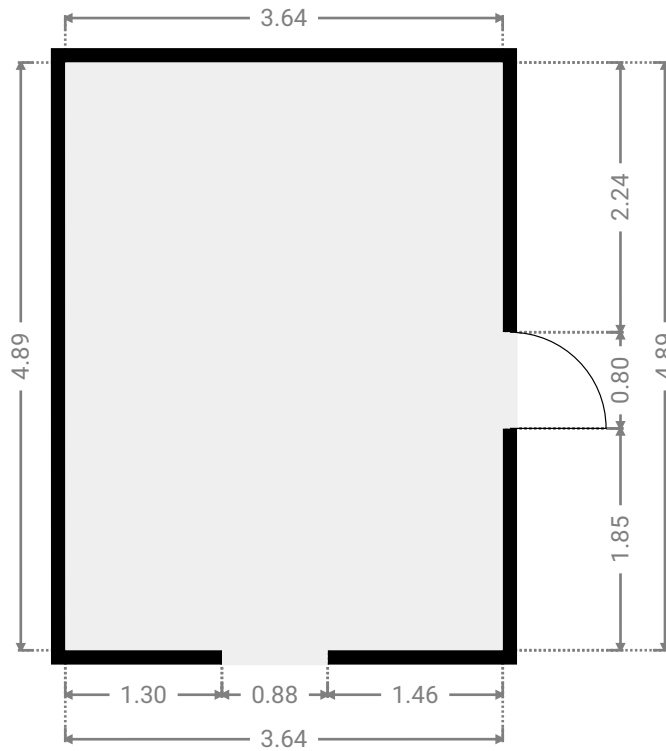
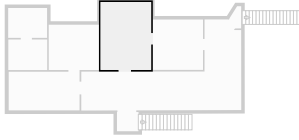

▼ Bedroom 1st Floor

WIDTH: 3.63 m • LENGTH: 3.26 m
AREA: 11.83 m² • PERIMETER: 13.78 m

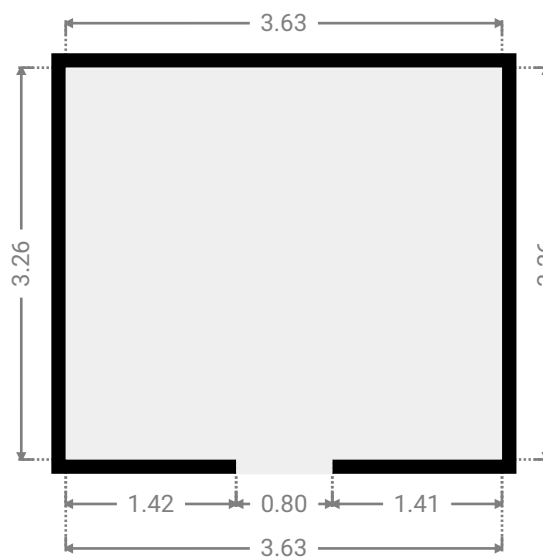
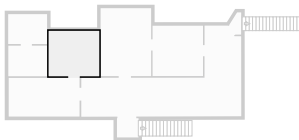

▼ **Hall**
1st Floor

WIDTH: 1.55 m • LENGTH: 1.38 m
AREA: 2.14 m² • PERIMETER: 5.87 m

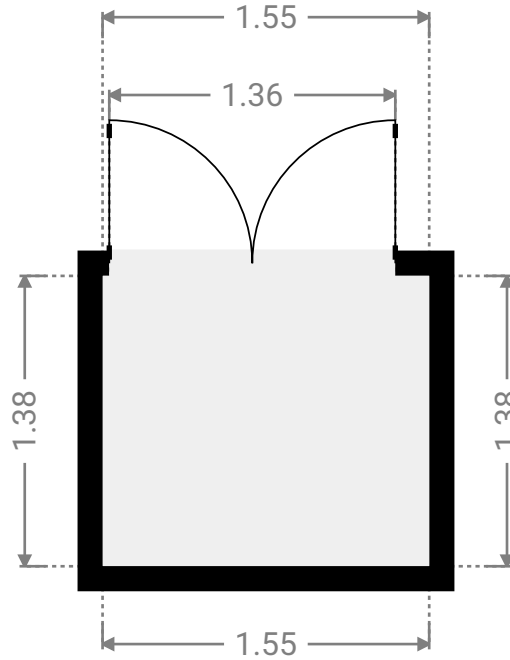
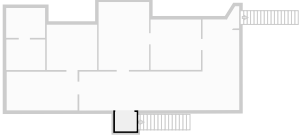

▼ **Hall**
1st Floor

WIDTH: 0.86 m • LENGTH: 1.60 m
AREA: 0.95 m² • PERIMETER: 4.18 m

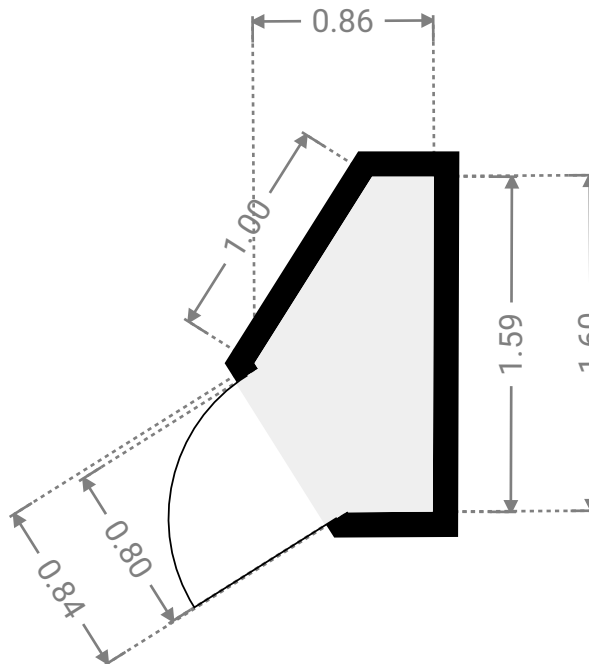
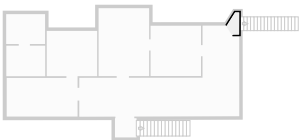

▼ Kitchen 1st Floor

WIDTH: 5.10 m • LENGTH: 2.78 m
AREA: 14.18 m² • PERIMETER: 15.76 m

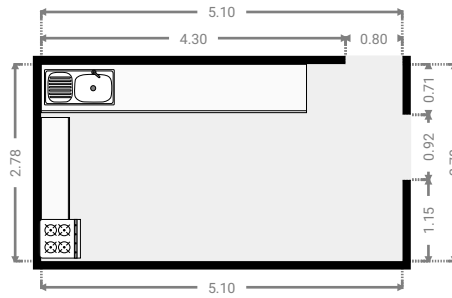
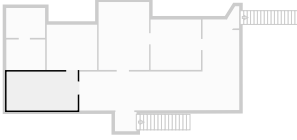

▼ Living Room 1st Floor

WIDTH: 11.52 m • LENGTH: 6.57 m
AREA: 41.46 m² • PERIMETER: 35.76 m

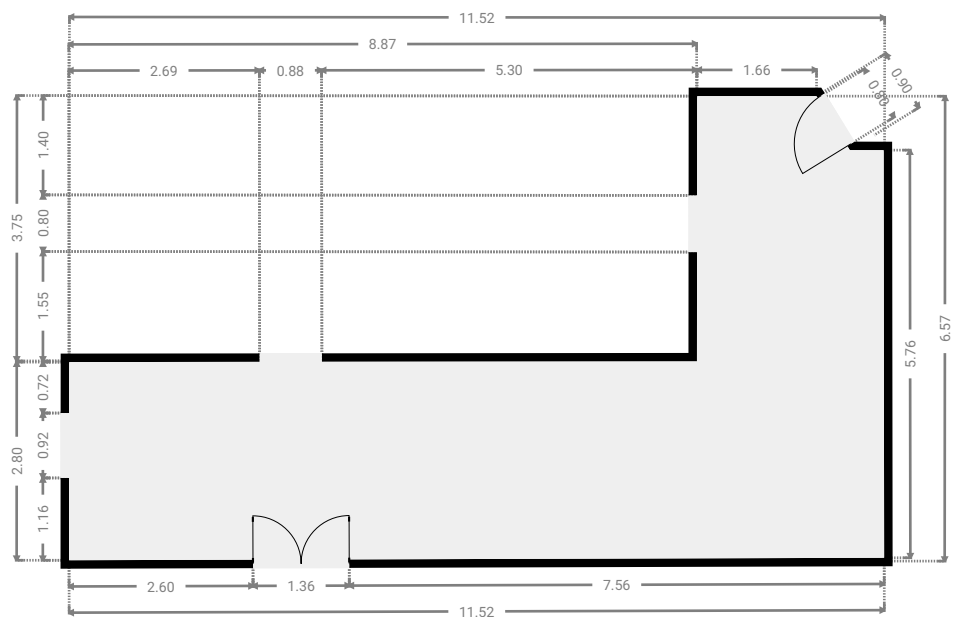
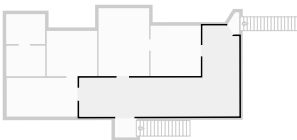

▼ Other
1st Floor

WIDTH: 2.80 m • LENGTH: 2.20 m
AREA: 6.16 m² • PERIMETER: 10.00 m

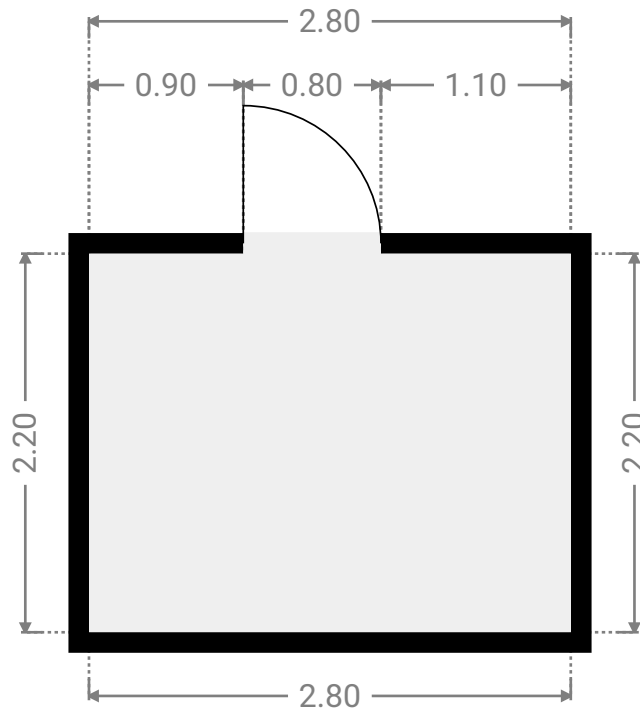
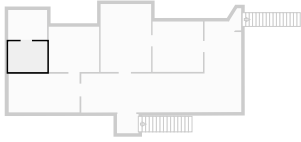

▼ 2nd Floor

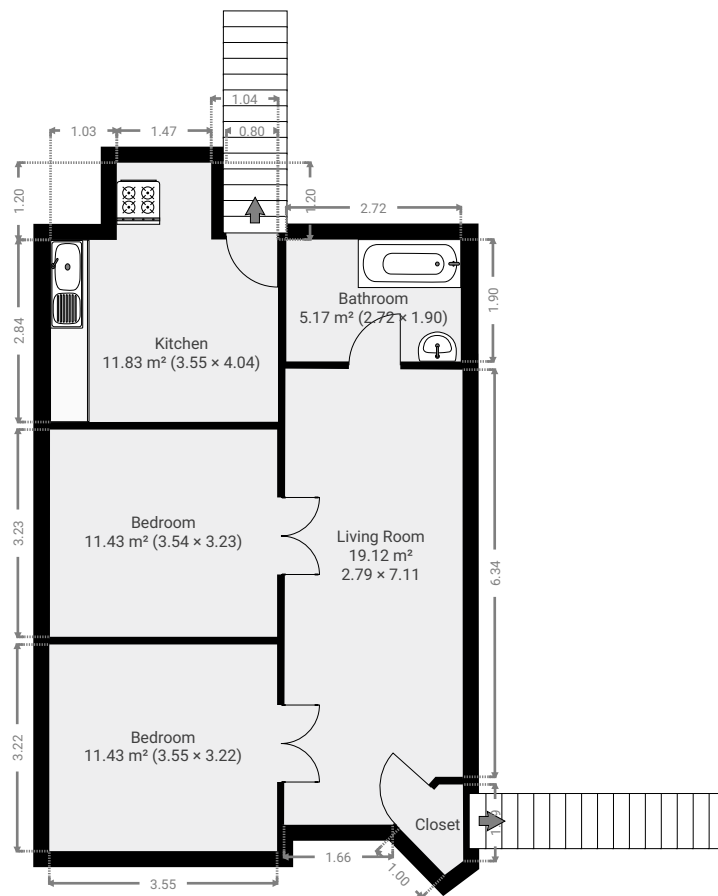

▼ **Bathroom**
2nd Floor

WIDTH: 2.72 m • LENGTH: 1.90 m
AREA: 5.17 m² • PERIMETER: 9.24 m

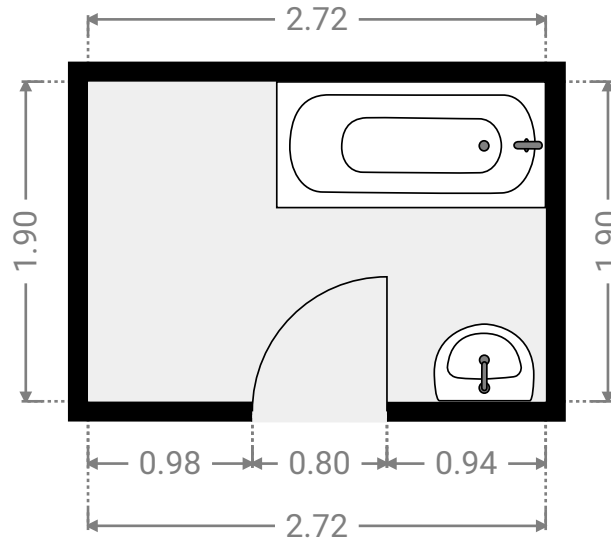
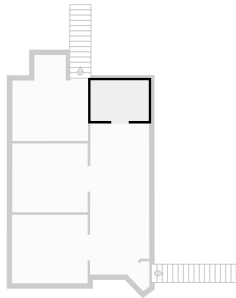

▼ **Bedroom**
2nd Floor

WIDTH: 3.55 m • LENGTH: 3.22 m
AREA: 11.43 m² • PERIMETER: 13.54 m

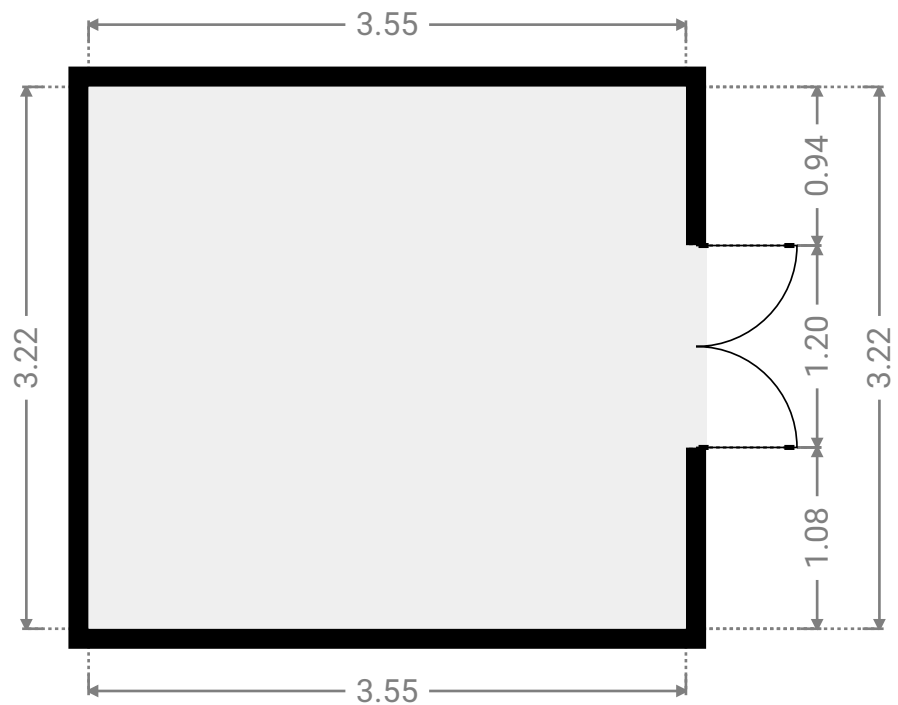
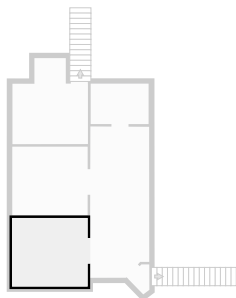

▼ **Bedroom**
2nd Floor

WIDTH: 3.54 m • LENGTH: 3.23 m
AREA: 11.43 m² • PERIMETER: 13.54 m

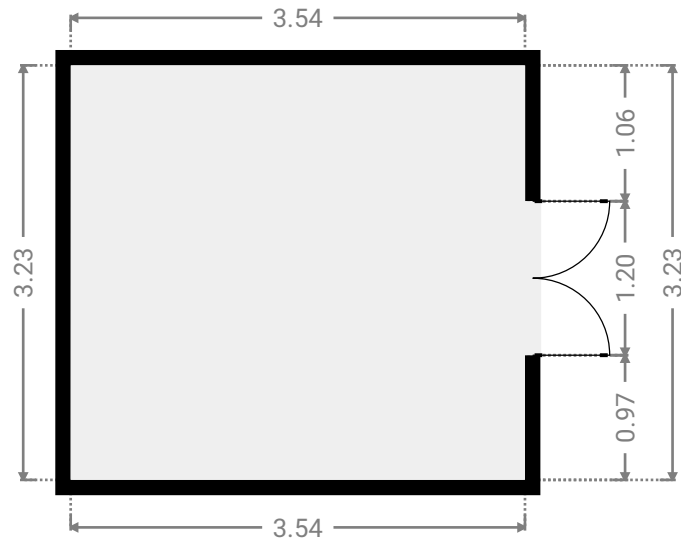
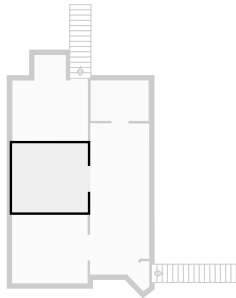

▼ **Kitchen**
2nd Floor

WIDTH: 3.55 m • LENGTH: 4.04 m
AREA: 11.83 m² • PERIMETER: 15.17 m

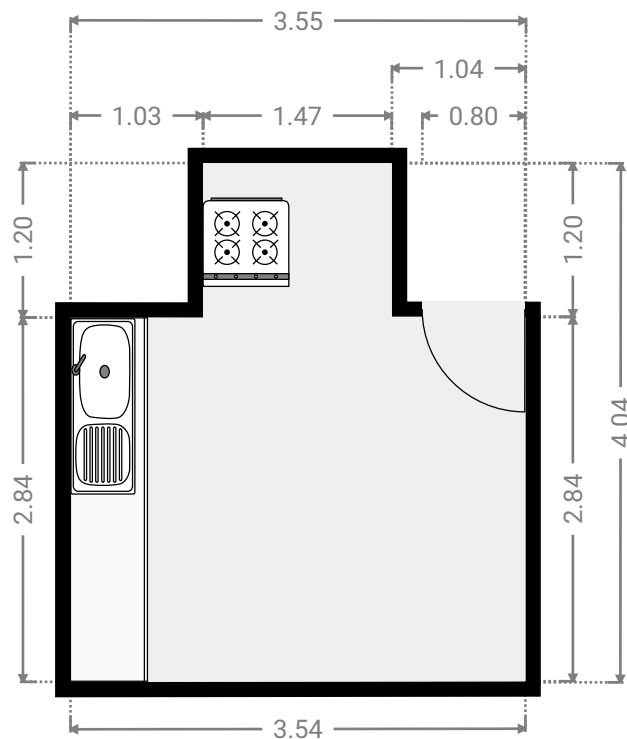
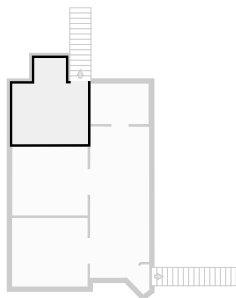

▼ Living Room 2nd Floor

WIDTH: 2.79 m • LENGTH: 7.11 m
AREA: 19.12 m² • PERIMETER: 19.33 m

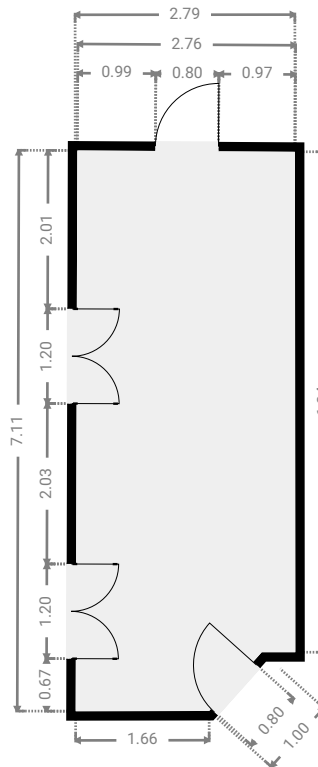
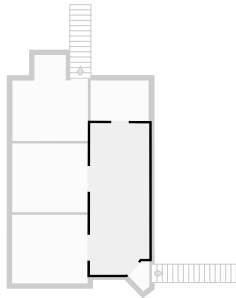

▼ Closet 2nd Floor

WIDTH: 0.99 m • LENGTH: 1.41 m
AREA: 0.90 m² • PERIMETER: 3.85 m

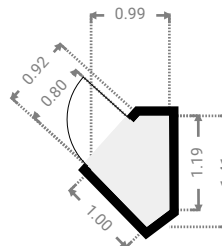
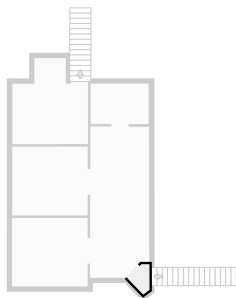

▼ 3rd Floor

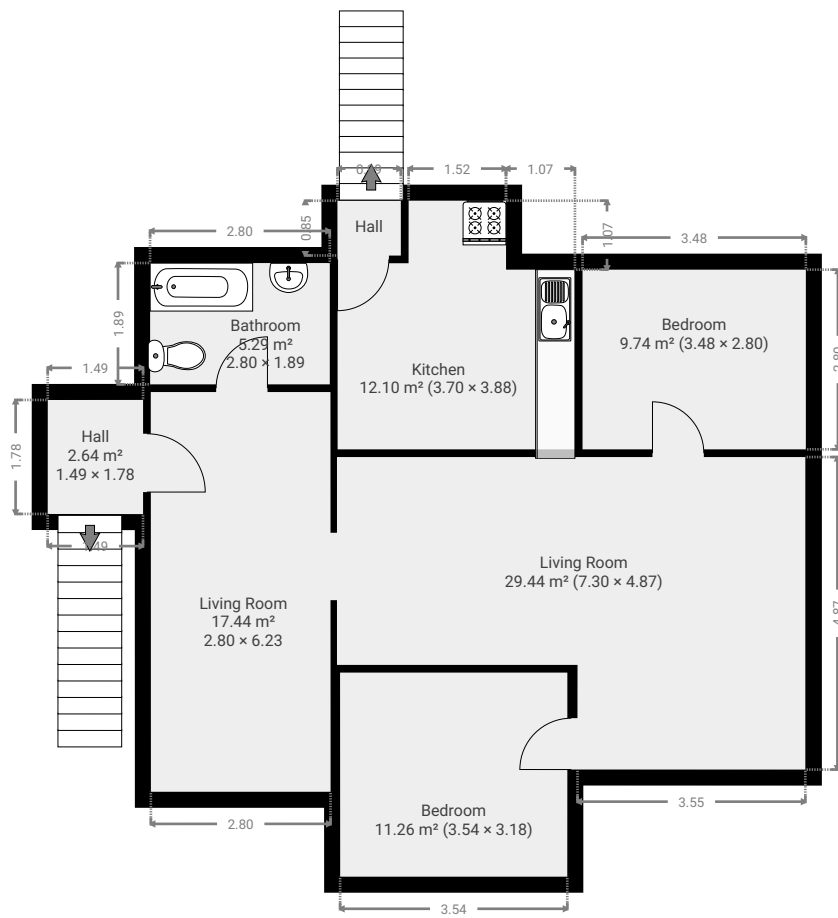

▼ **Bathroom**
3rd Floor

WIDTH: 1.89 m • LENGTH: 2.80 m
AREA: 5.29 m² • PERIMETER: 9.38 m

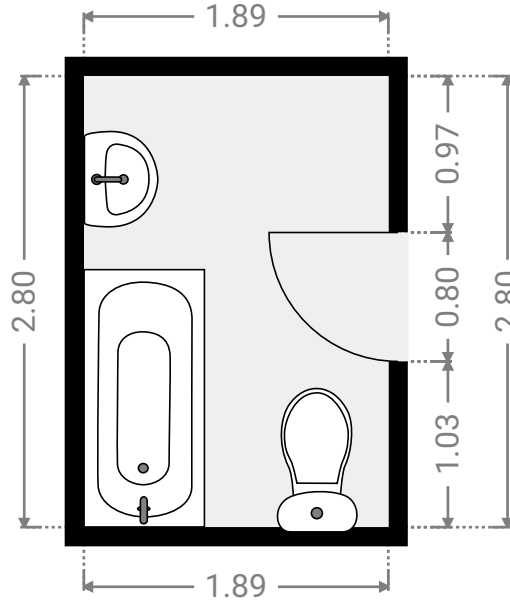
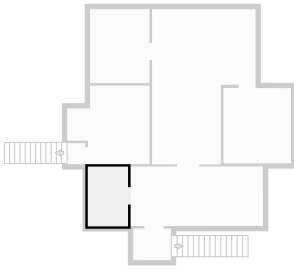

▼ **Bedroom**
3rd Floor

WIDTH: 2.80 m • LENGTH: 3.48 m
AREA: 9.74 m² • PERIMETER: 12.56 m

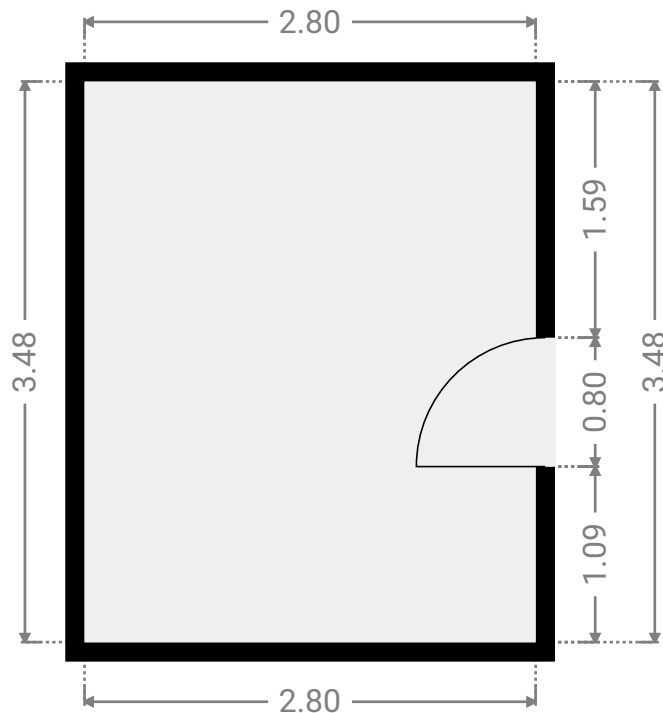
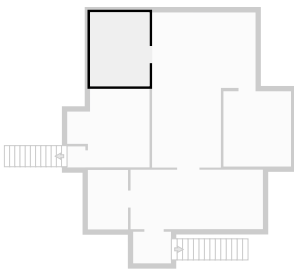

▼ **Bedroom**
3rd Floor

WIDTH: 3.18 m • LENGTH: 3.54 m
AREA: 11.26 m² • PERIMETER: 13.44 m

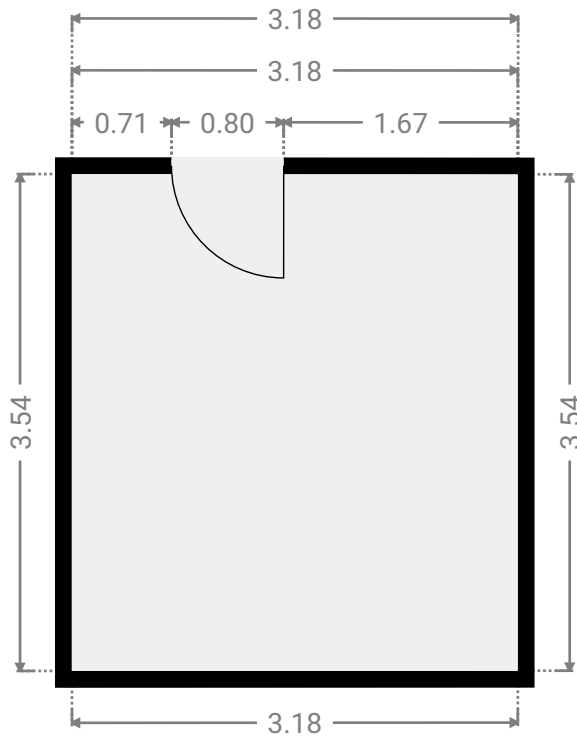
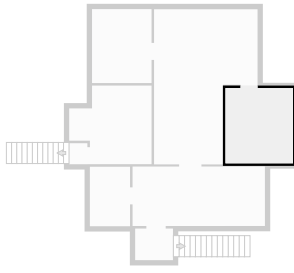

▼ **Hall**
3rd Floor

WIDTH: 0.85 m • LENGTH: 0.99 m
AREA: 0.84 m² • PERIMETER: 3.68 m

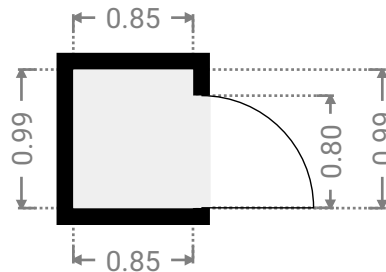
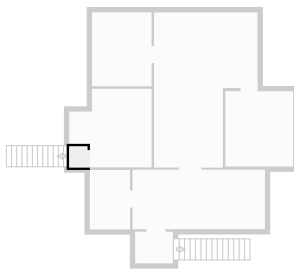

▼ **Hall**
3rd Floor

WIDTH: 1.78 m • LENGTH: 1.49 m
AREA: 2.64 m² • PERIMETER: 6.53 m

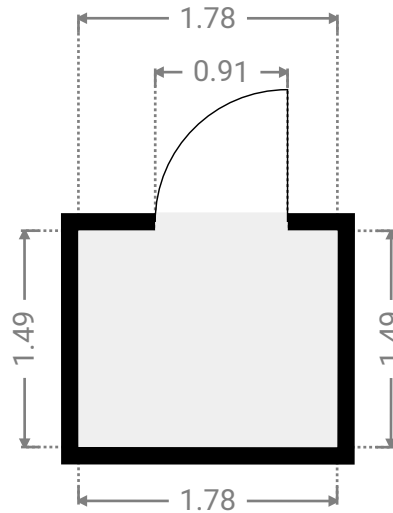
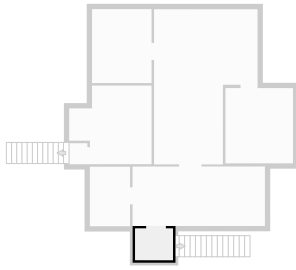

▼ **Kitchen**
3rd Floor

WIDTH: 3.88 m • LENGTH: 3.70 m
AREA: 12.10 m² • PERIMETER: 15.15 m

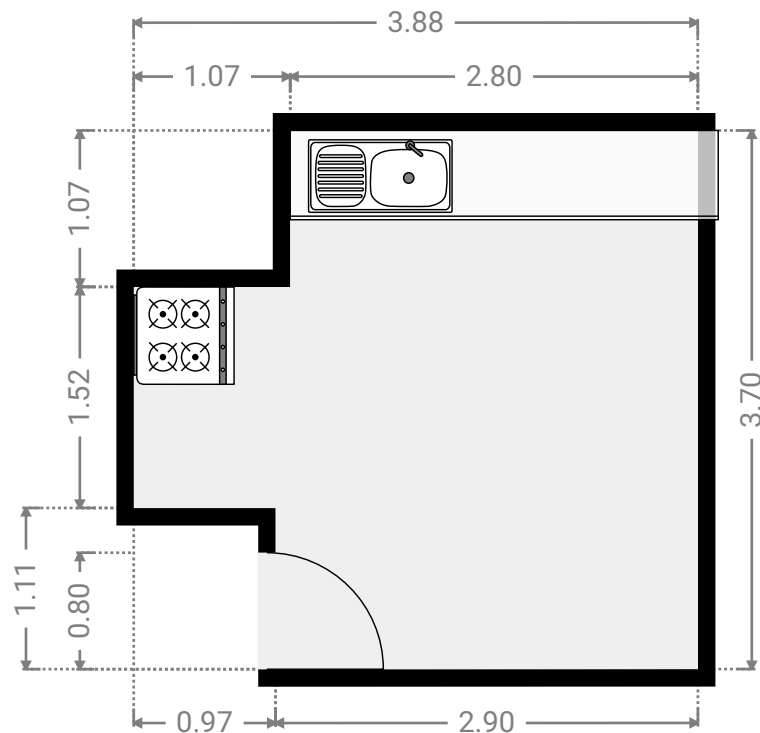
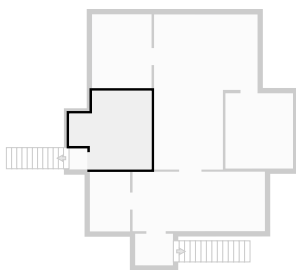

▼ Living Room
3rd Floor

WIDTH: 6.23 m • LENGTH: 2.80 m
AREA: 17.44 m² • PERIMETER: 18.06 m

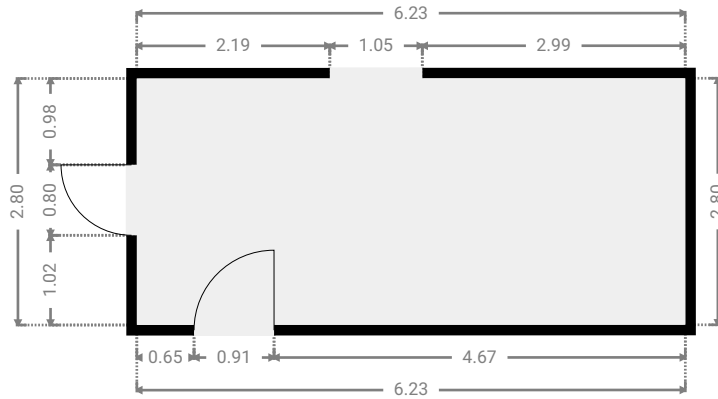
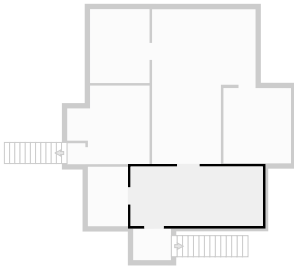

▼ Living Room
3rd Floor

WIDTH: 4.87 m • LENGTH: 7.30 m
AREA: 29.44 m² • PERIMETER: 24.34 m

