

37 Inveraray Way

SUBMITTED BY

Ray White Rockhampton Casey
stockers@cqoz.com

CREATED ON

2021-11-11

Floors

1

▼ Ground Floor

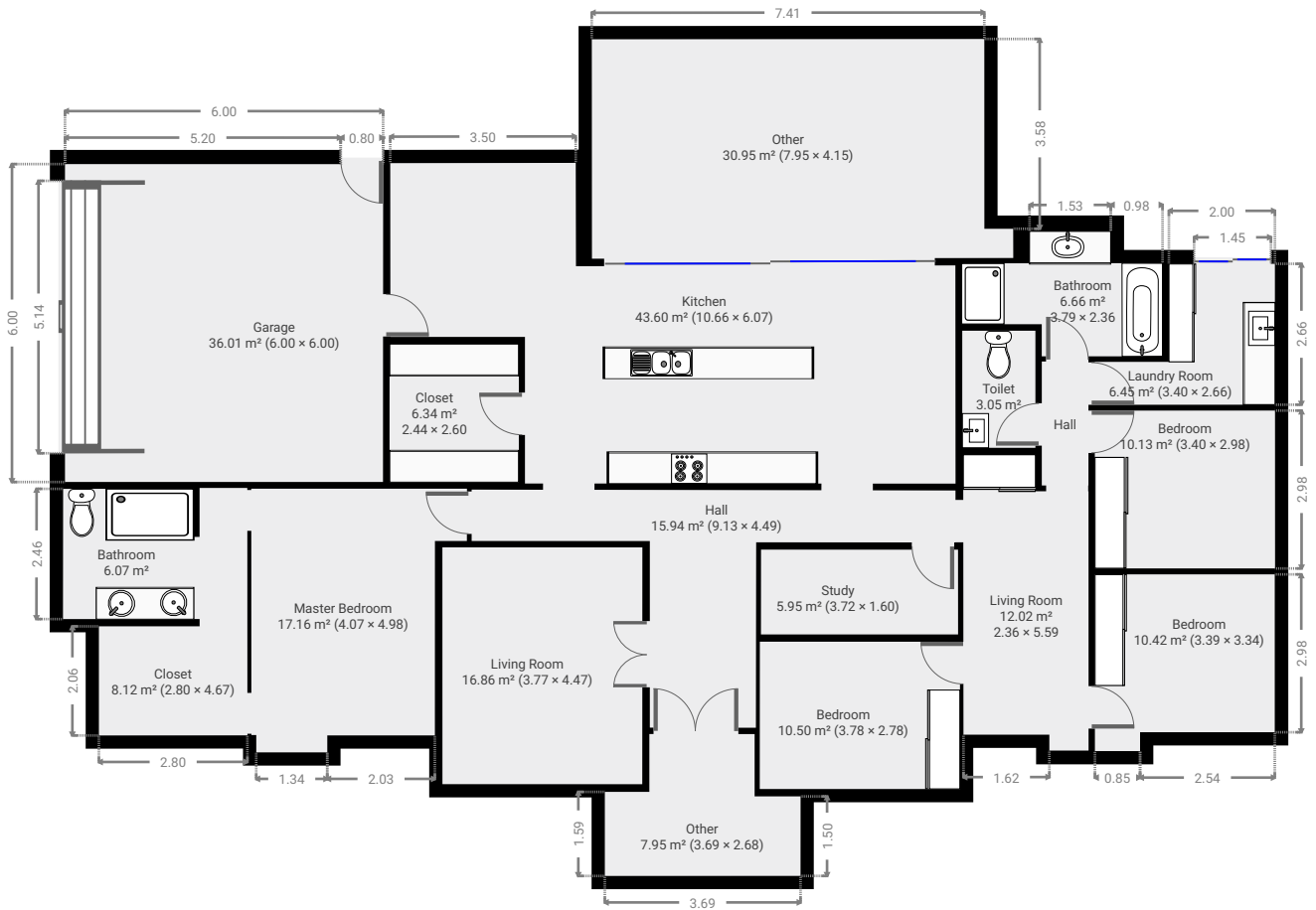
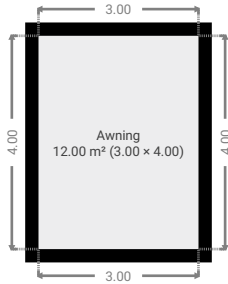

FLOORS: 1

▼ **Bedroom**
Ground Floor

WIDTH: 3.39 m • LENGTH: 3.34 m
AREA: 10.42 m² • PERIMETER: 13.46 m

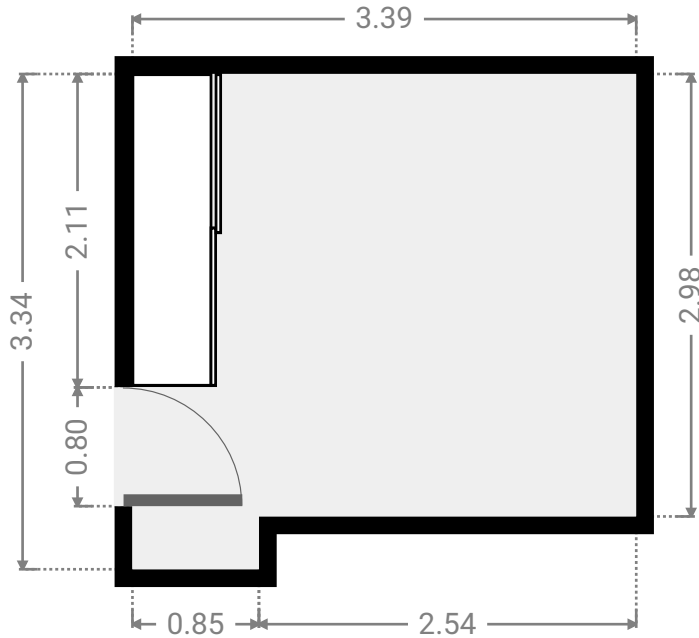
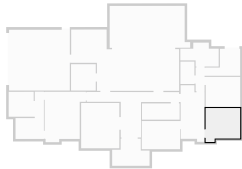

▼ **Awning**
Ground Floor

WIDTH: 3.00 m • LENGTH: 4.00 m
AREA: 12.00 m² • PERIMETER: 14.00 m

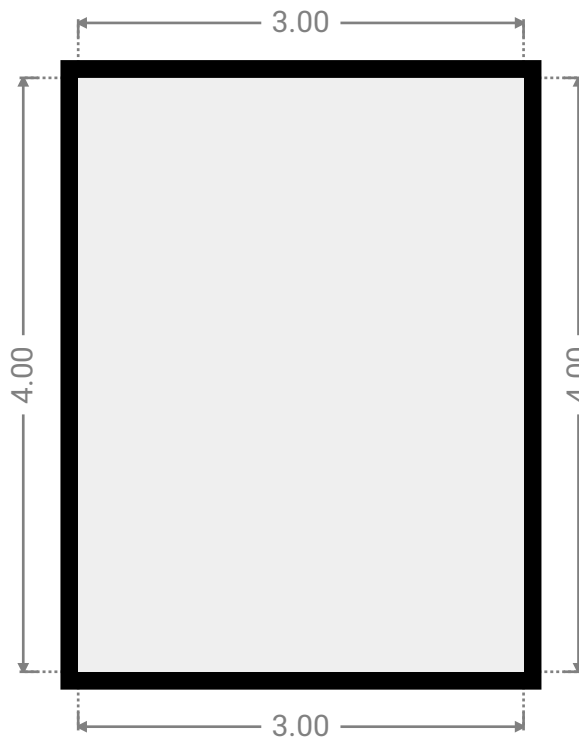
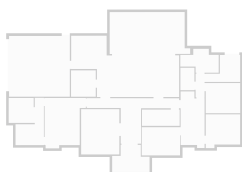

▼ Other Ground Floor

WIDTH: 3.69 m • LENGTH: 2.68 m
AREA: 7.95 m² • PERIMETER: 12.74 m

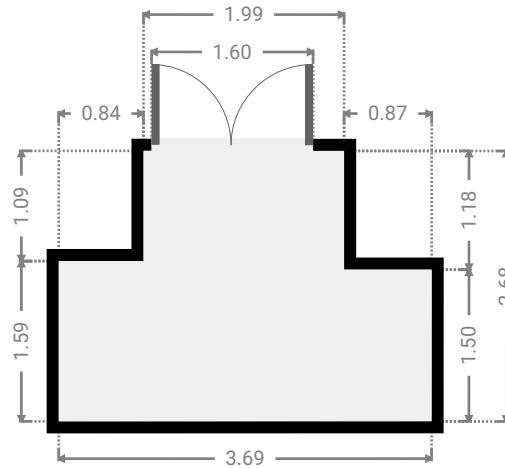
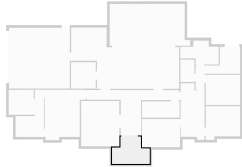

▼ Other Ground Floor

WIDTH: 7.95 m • LENGTH: 4.15 m
AREA: 30.95 m² • PERIMETER: 24.18 m

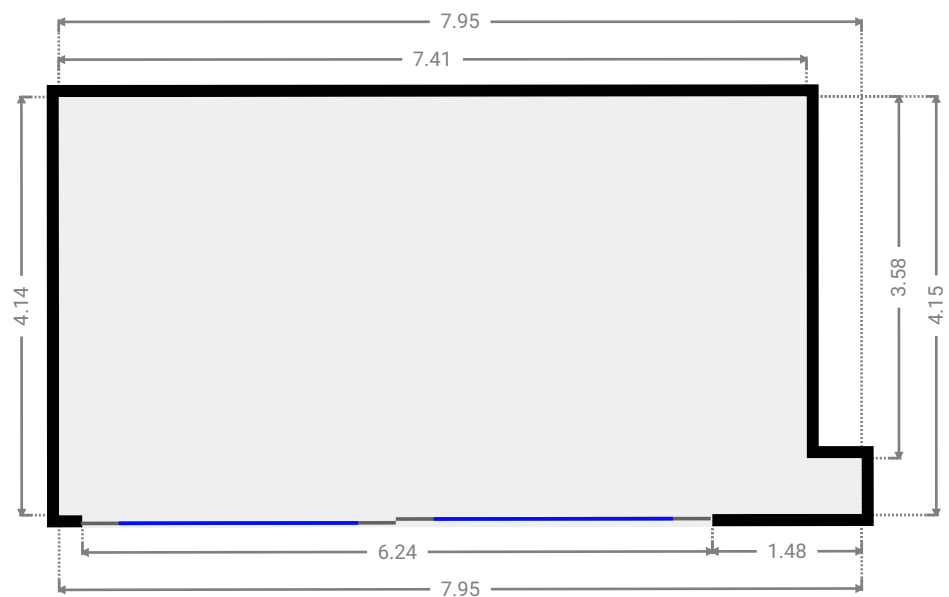
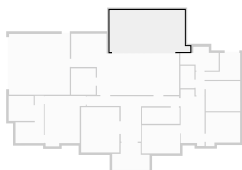

FLOORS: 1

▼ Garage Ground Floor

WIDTH: 6.00 m • LENGTH: 6.00 m
AREA: 36.01 m² • PERIMETER: 24.00 m

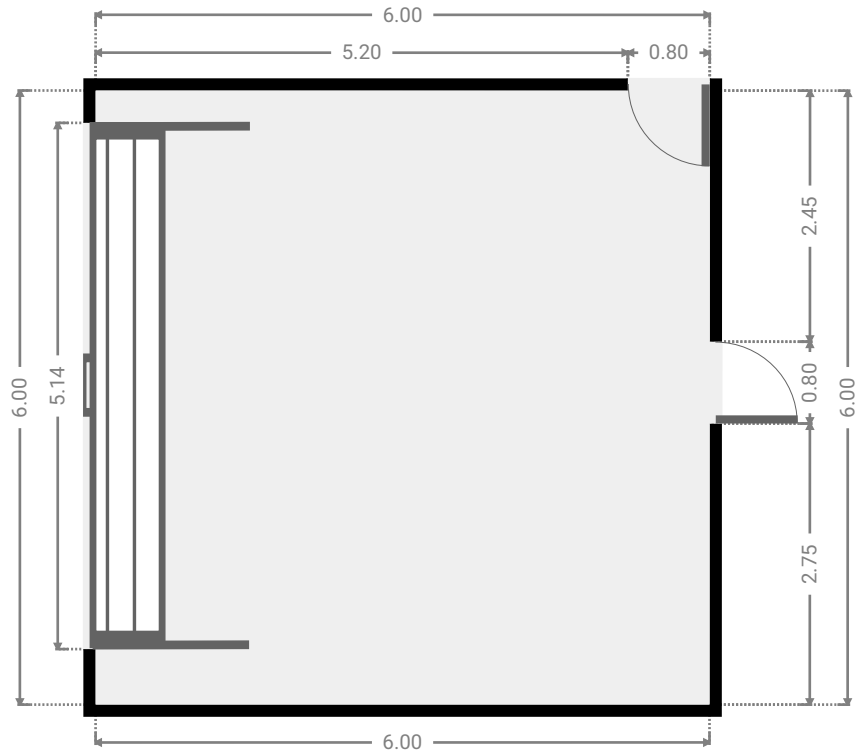
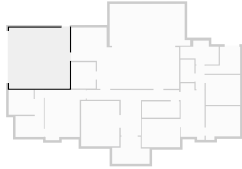

▼ Closet Ground Floor

WIDTH: 2.44 m • LENGTH: 2.60 m
AREA: 6.34 m² • PERIMETER: 10.08 m

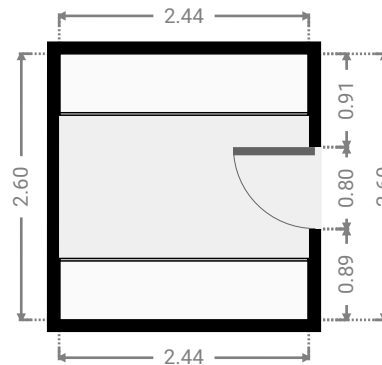
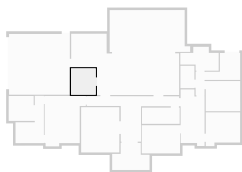

FLOORS: 1

▼ **Bathroom**
Ground Floor

WIDTH: 3.79 m • LENGTH: 2.36 m
AREA: 6.66 m² • PERIMETER: 12.29 m

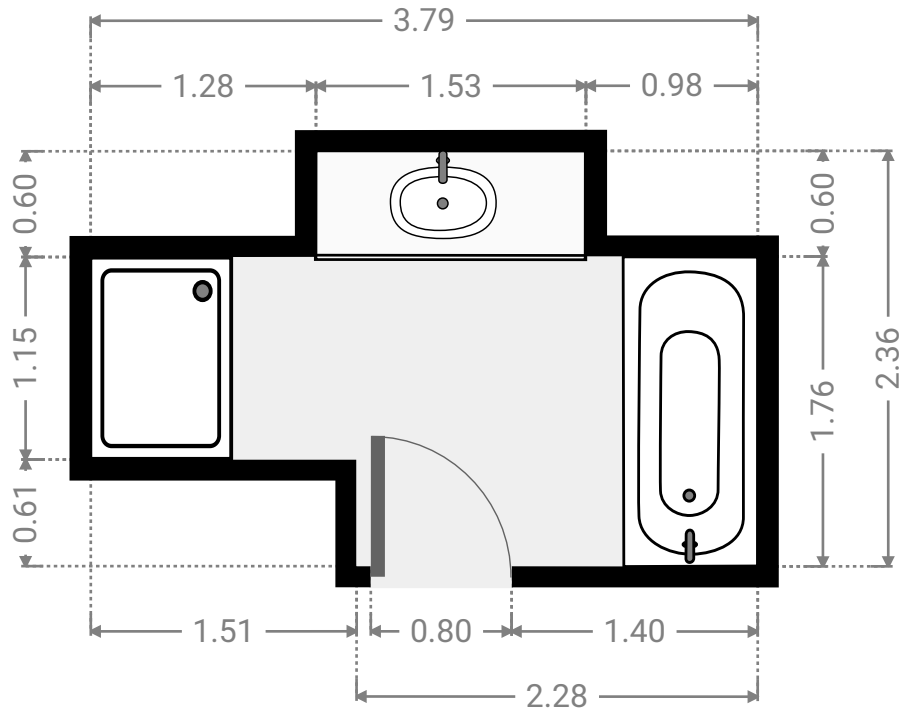
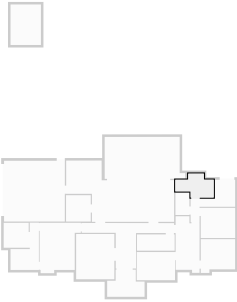

▼ **Laundry Room**
Ground Floor

WIDTH: 3.40 m • LENGTH: 2.66 m
AREA: 6.45 m² • PERIMETER: 12.12 m

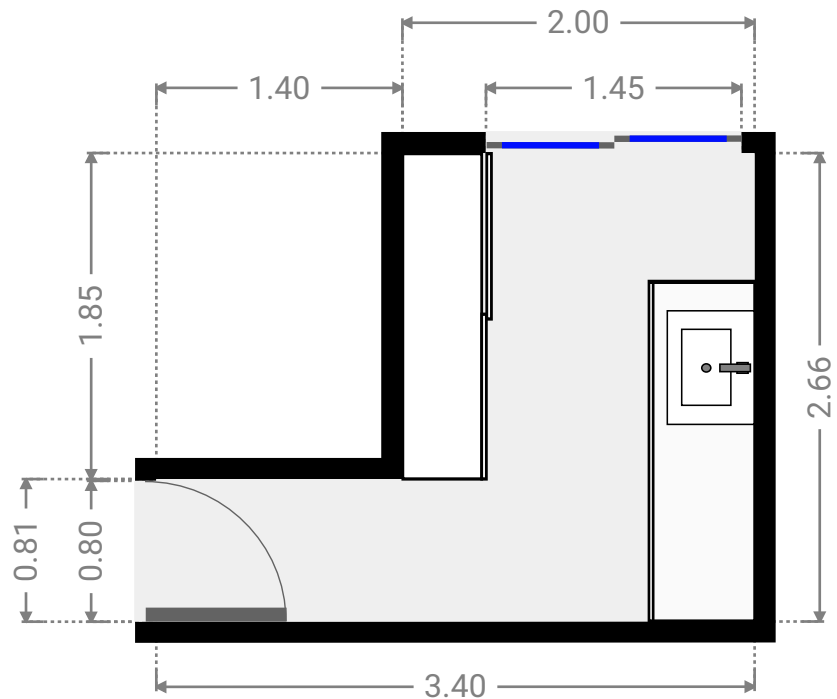
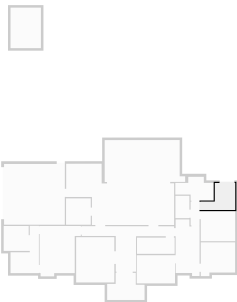

FLOORS: 1

▼ **Bedroom**
Ground Floor

WIDTH: 3.40 m • LENGTH: 2.98 m
AREA: 10.13 m² • PERIMETER: 12.76 m

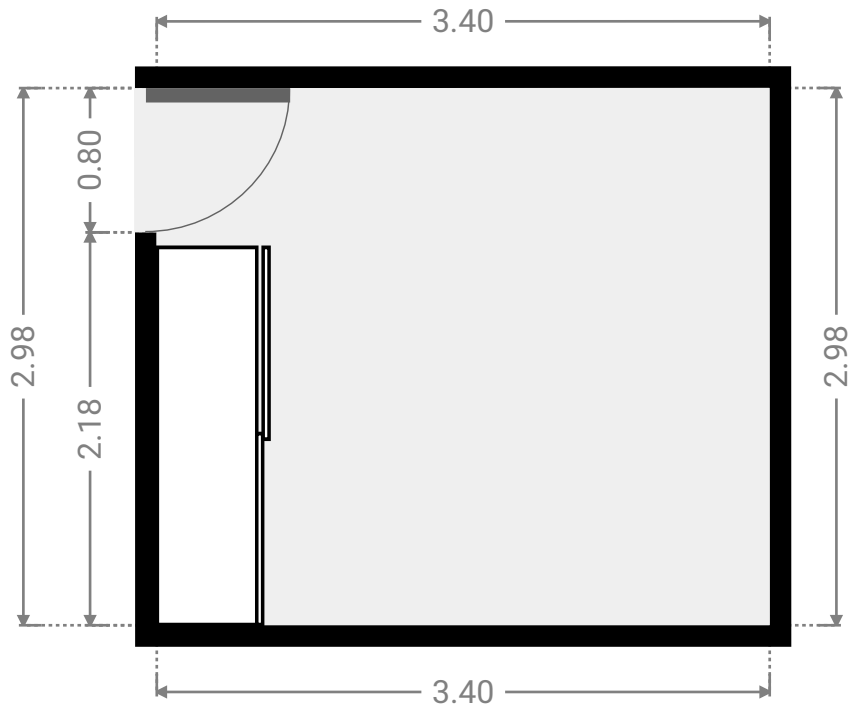
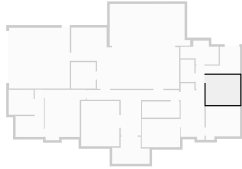

▼ **Toilet**
Ground Floor

WIDTH: 1.38 m • LENGTH: 2.21 m
AREA: 3.05 m² • PERIMETER: 7.18 m

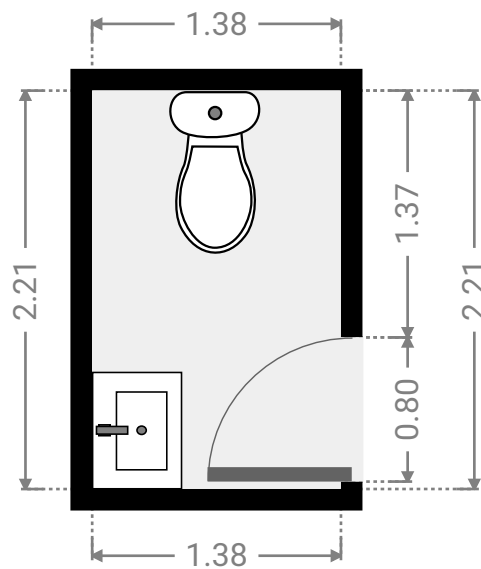
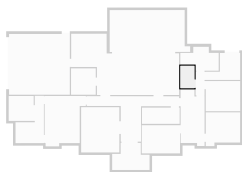

FLOORS: 1

▼ **Hall**
Ground Floor

WIDTH: 9.13 m • LENGTH: 4.49 m
AREA: 15.94 m² • PERIMETER: 27.23 m

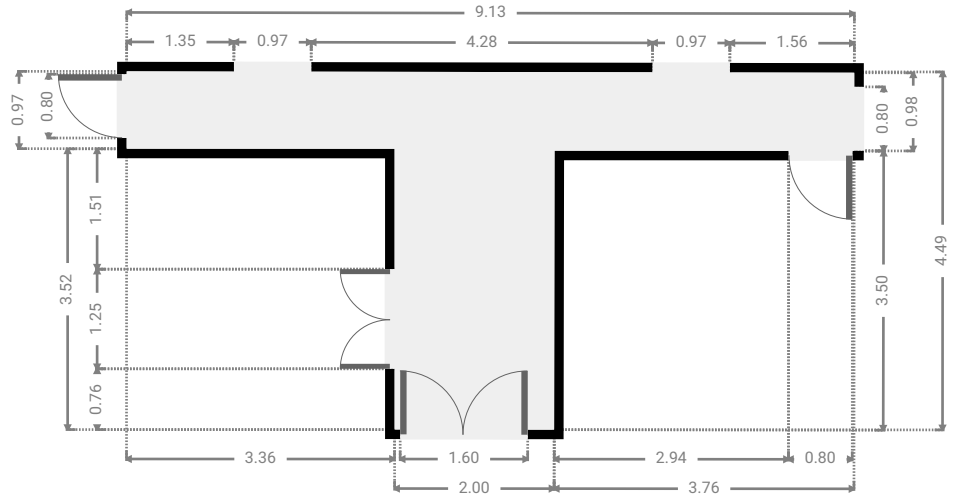
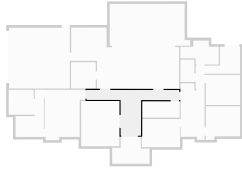

▼ **Bedroom**
Ground Floor

WIDTH: 3.78 m • LENGTH: 2.78 m
AREA: 10.50 m² • PERIMETER: 13.12 m

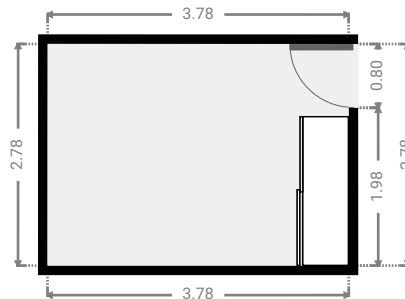
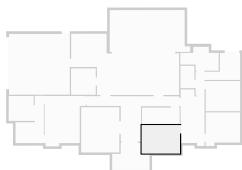

FLOORS: 1

▼ **Hall**
Ground Floor

WIDTH: 0.88 m • LENGTH: 2.34 m
AREA: 2.06 m² • PERIMETER: 6.44 m

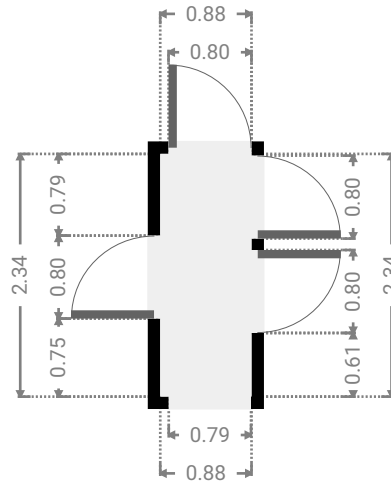
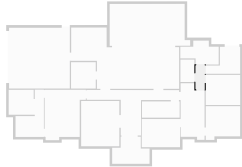

▼ **Living Room**
Ground Floor

WIDTH: 2.36 m • LENGTH: 5.59 m
AREA: 12.02 m² • PERIMETER: 15.90 m

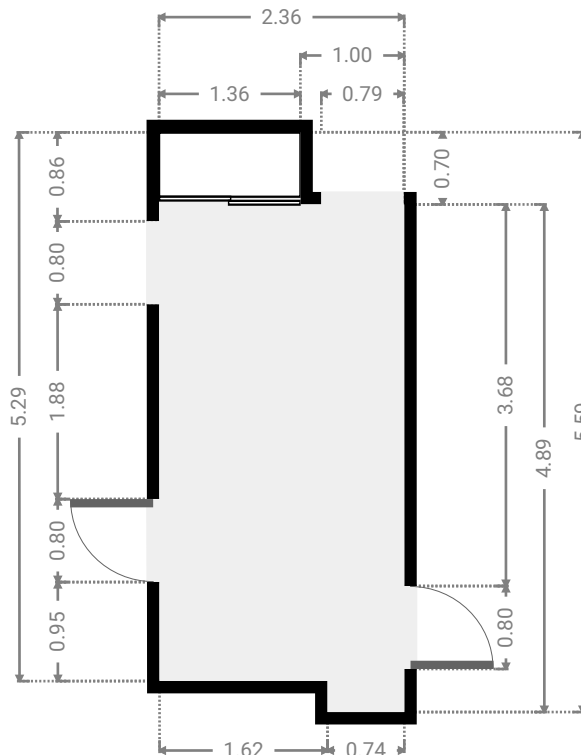
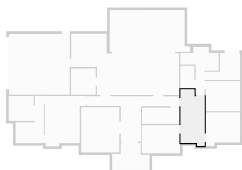

FLOORS: 1

▼ Study Ground Floor

WIDTH: 3.72 m • LENGTH: 1.60 m
AREA: 5.95 m² • PERIMETER: 10.64 m

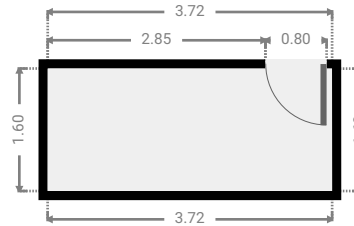
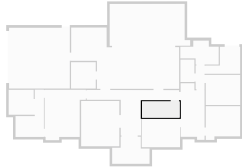

▼ Kitchen Ground Floor

WIDTH: 10.66 m • LENGTH: 6.07 m
AREA: 43.60 m² • PERIMETER: 33.44 m

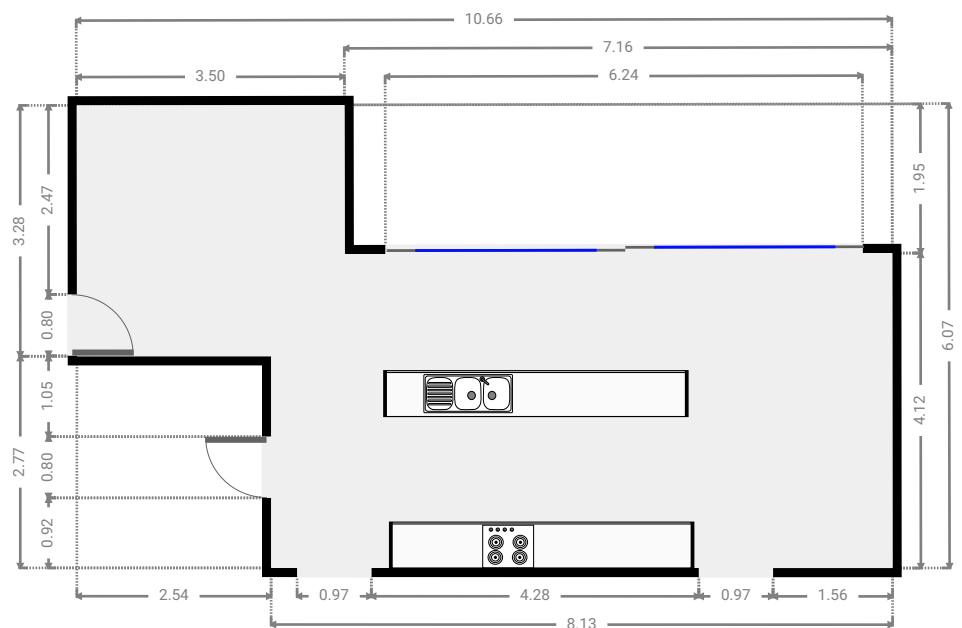
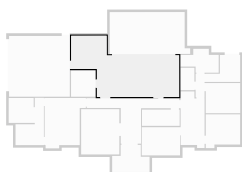

FLOORS: 1

▼ **Bathroom**
Ground Floor

WIDTH: 2.47 m • LENGTH: 2.46 m
AREA: 6.07 m² • PERIMETER: 9.85 m

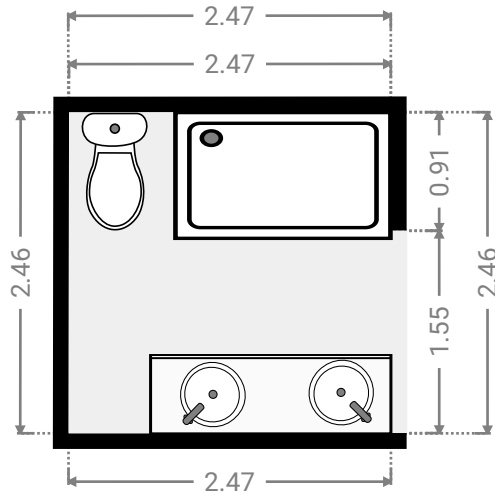
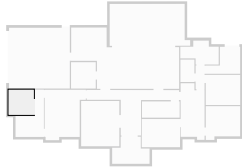

▼ **Closet**
Ground Floor

WIDTH: 2.80 m • LENGTH: 4.67 m
AREA: 8.12 m² • PERIMETER: 14.94 m

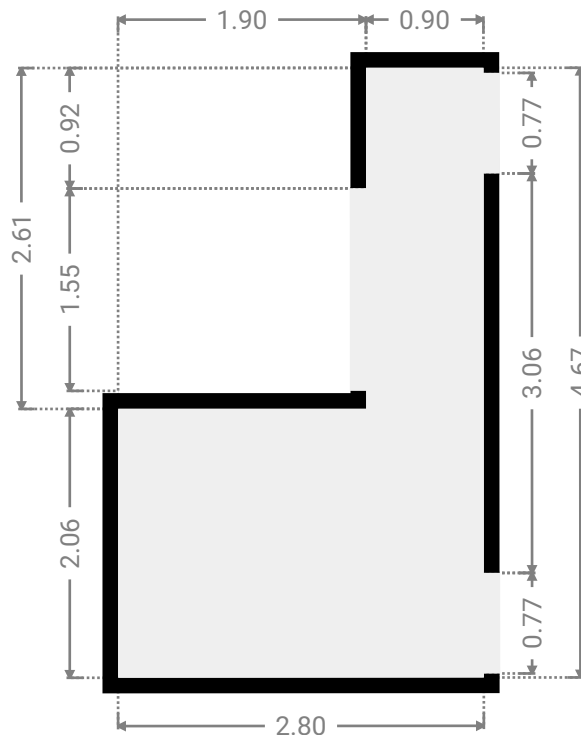
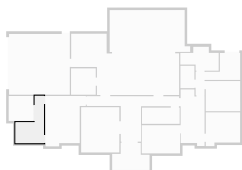

FLOORS: 1

▼ Master Bedroom Ground Floor

WIDTH: 4.07 m • LENGTH: 4.98 m
AREA: 17.16 m² • PERIMETER: 18.09 m

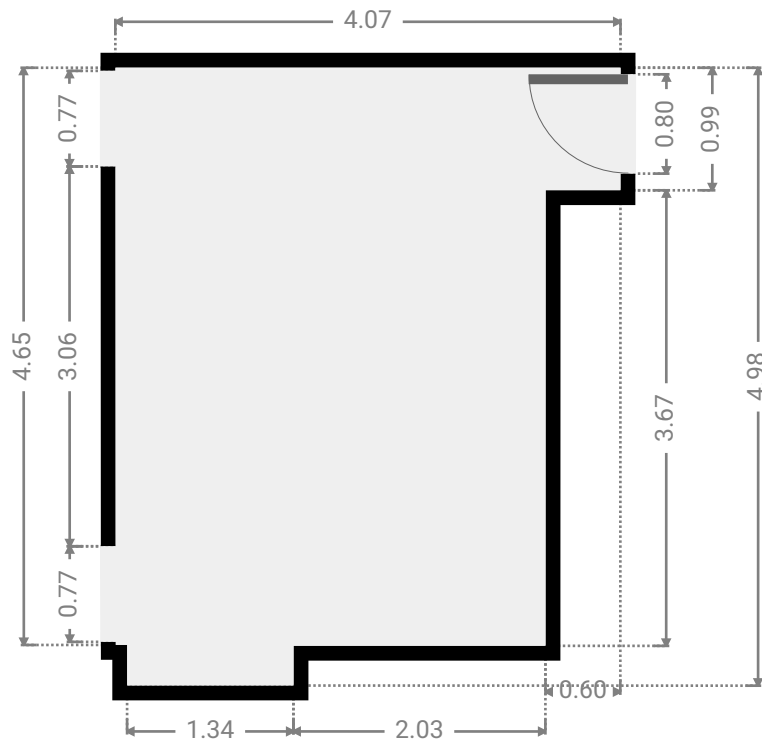
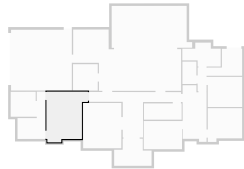

▼ Living Room Ground Floor

WIDTH: 3.77 m • LENGTH: 4.47 m
AREA: 16.86 m² • PERIMETER: 16.48 m

