

# 37 Corberry Street

**SUBMITTED BY**

Ray White Rockhampton Casey  
stockers@cqoz.com

---

**CREATED ON**

2021-04-12

---

**Floors**

2

---

▼ Ground Floor

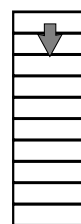
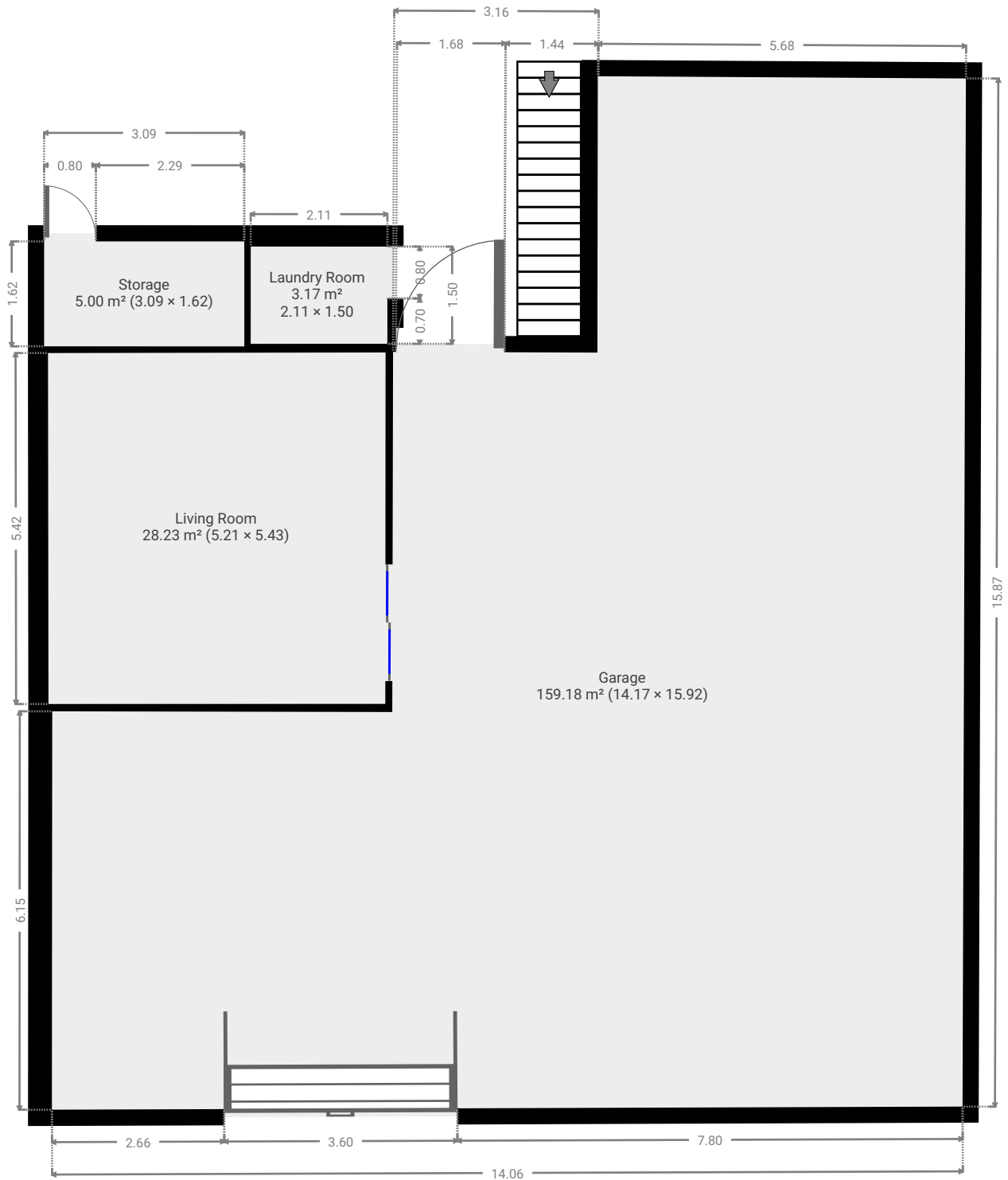

▼ **Garage**  
Ground Floor

WIDTH: 14.17 m • LENGTH: 15.92 m  
AREA: 159.18 m<sup>2</sup> • PERIMETER: 59.99 m

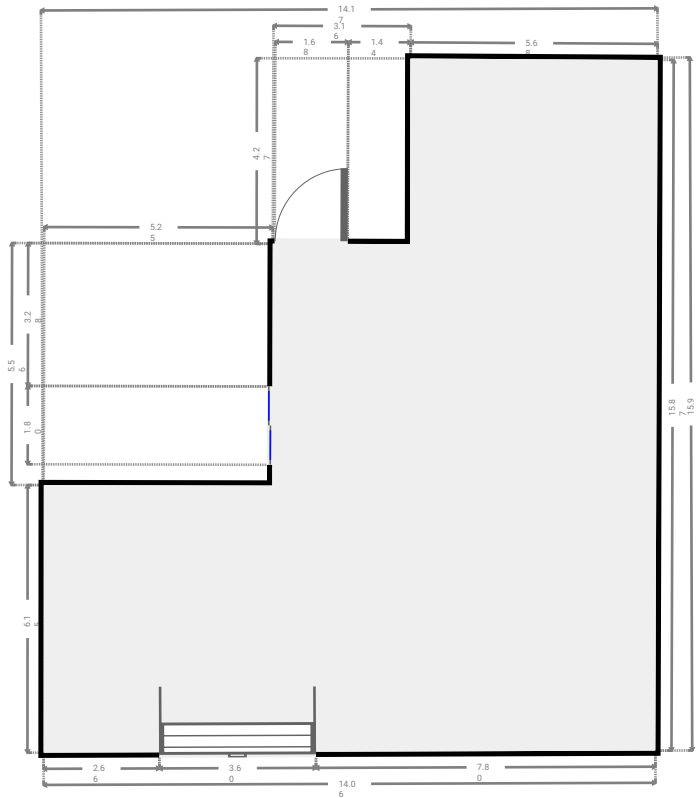
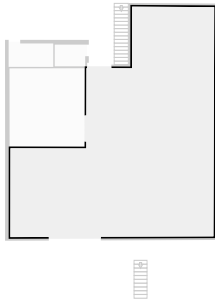

▼ **Living Room**  
Ground Floor

WIDTH: 5.21 m • LENGTH: 5.43 m  
AREA: 28.23 m<sup>2</sup> • PERIMETER: 21.26 m

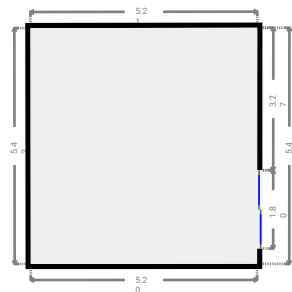
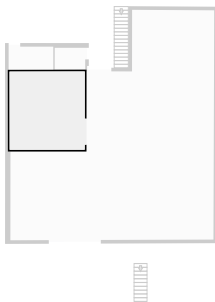

▼ **Laundry Room**  
Ground Floor

WIDTH: 2.11 m • LENGTH: 1.50 m  
AREA: 3.17 m<sup>2</sup> • PERIMETER: 7.22 m

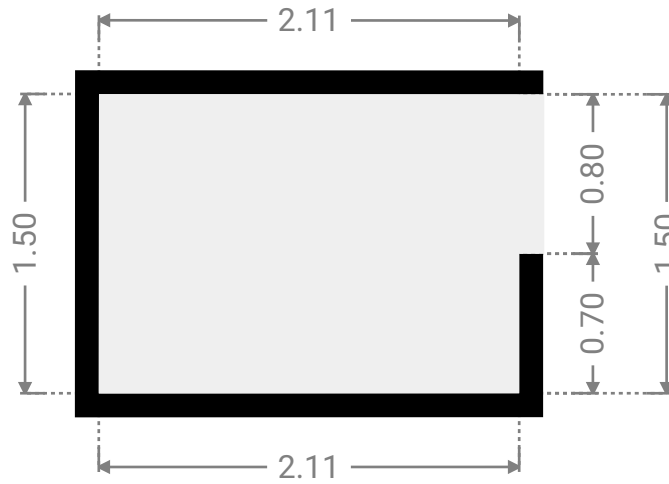
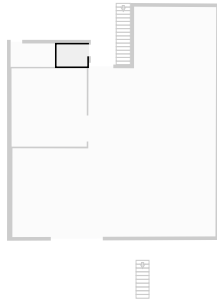

▼ **Storage**  
Ground Floor

WIDTH: 3.09 m • LENGTH: 1.62 m  
AREA: 5.00 m<sup>2</sup> • PERIMETER: 9.42 m

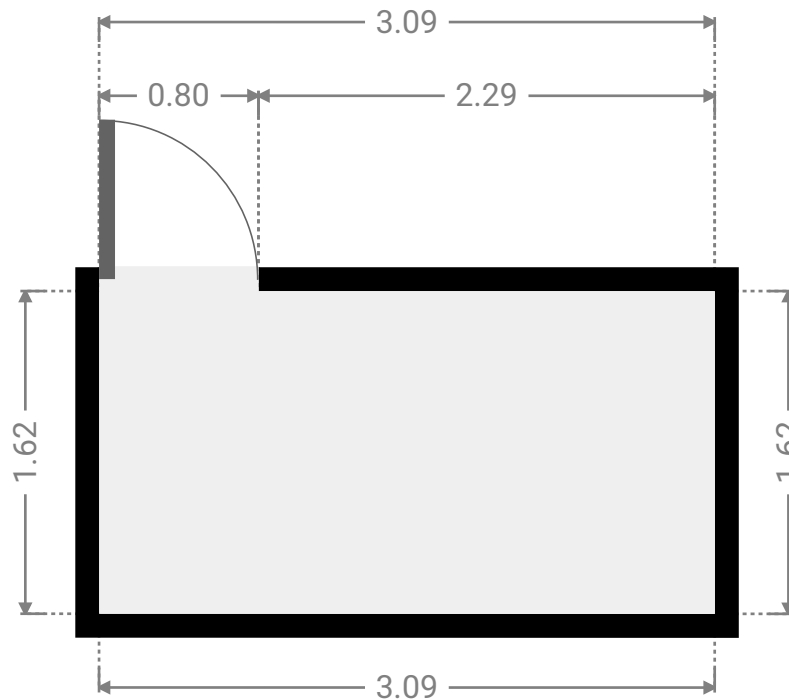
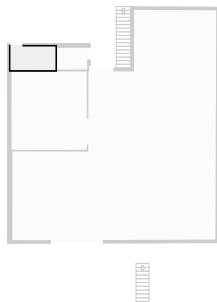

▼ 1st Floor

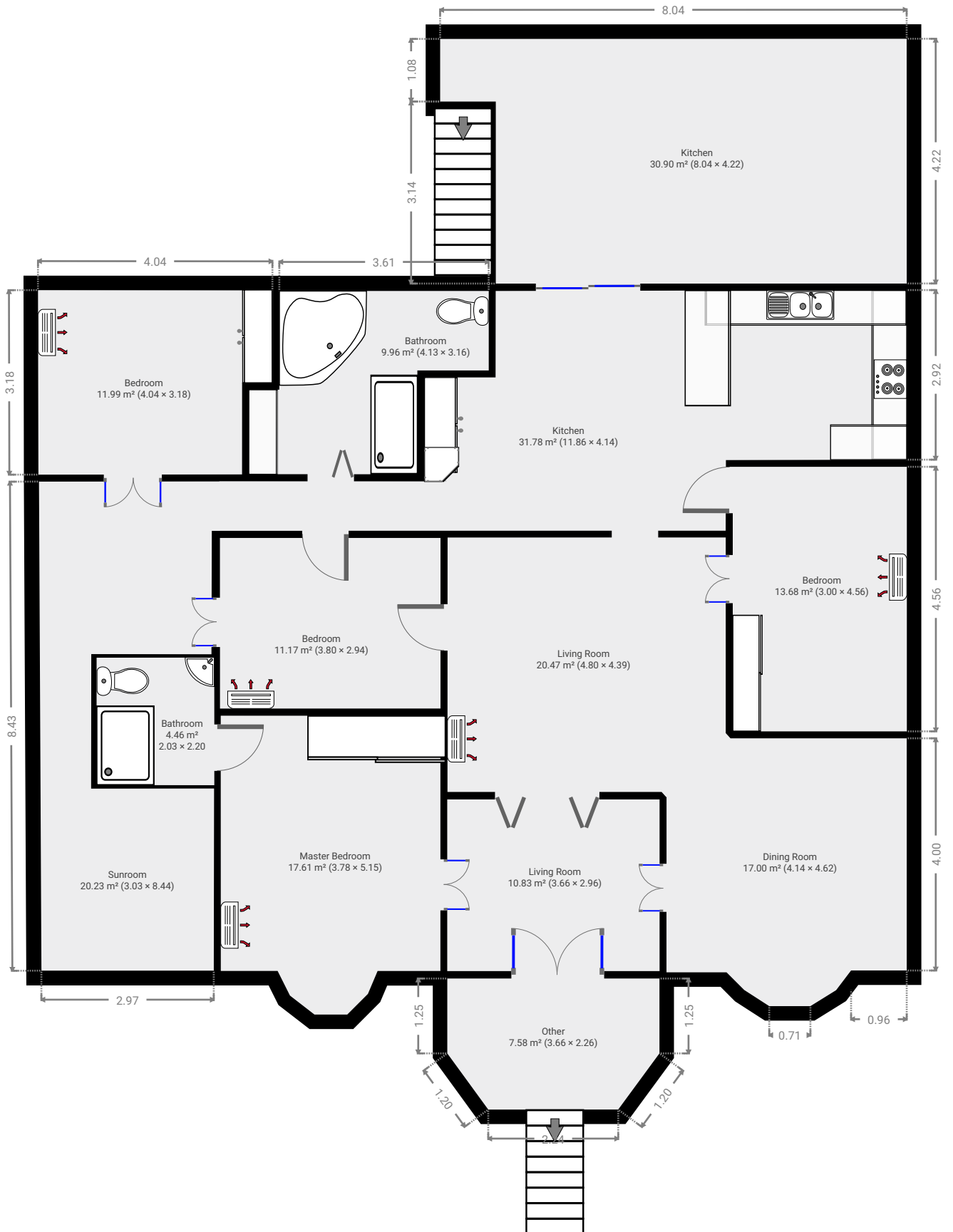

▼ Living Room  
1st Floor

WIDTH: 3.66 m • LENGTH: 2.96 m  
AREA: 10.83 m<sup>2</sup> • PERIMETER: 13.24 m

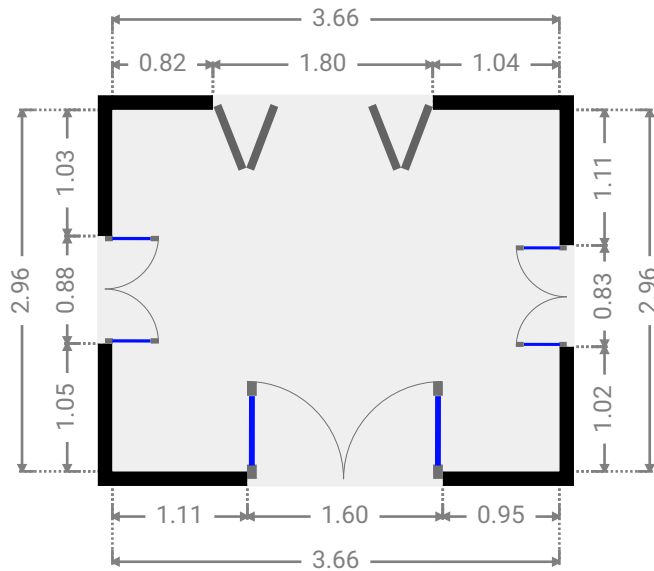
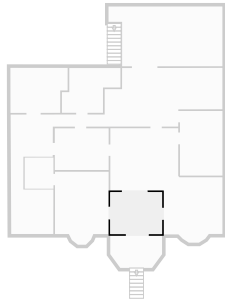

▼ Master Bedroom  
1st Floor

WIDTH: 3.78 m • LENGTH: 5.15 m  
AREA: 17.61 m<sup>2</sup> • PERIMETER: 17.15 m

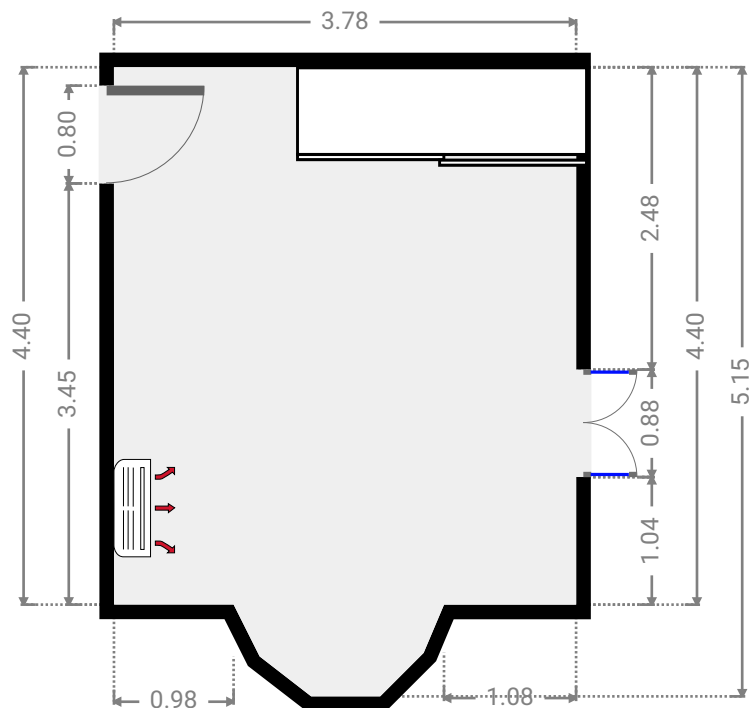
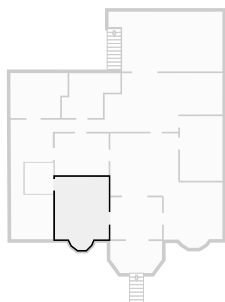

## ▼ Sunroom 1st Floor

WIDTH: 3.03 m • LENGTH: 8.44 m  
AREA: 20.23 m<sup>2</sup> • PERIMETER: 27.01 m

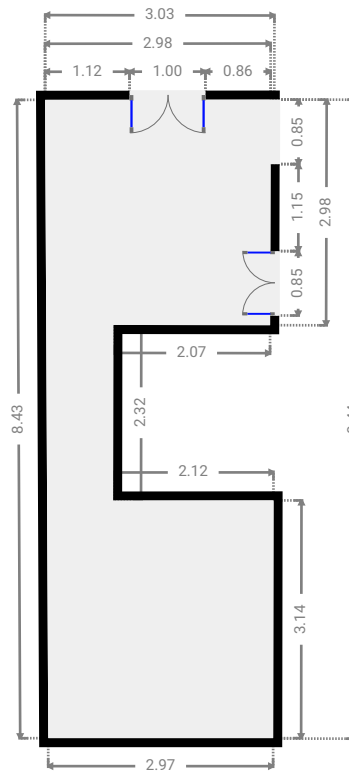
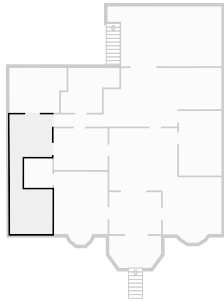

## ▼ Bathroom 1st Floor

WIDTH: 2.03 m • LENGTH: 2.20 m  
AREA: 4.46 m<sup>2</sup> • PERIMETER: 8.45 m

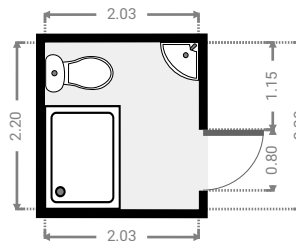
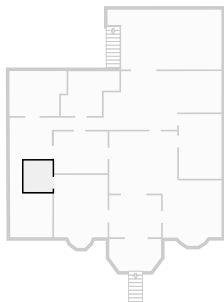

▼ **Bedroom**  
1st Floor

WIDTH: 3.80 m • LENGTH: 2.94 m  
AREA: 11.17 m<sup>2</sup> • PERIMETER: 13.48 m

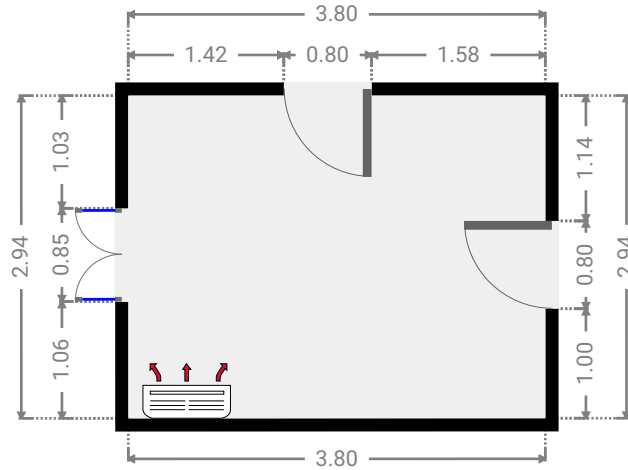
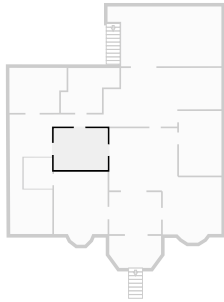

▼ **Living Room**  
1st Floor

WIDTH: 4.80 m • LENGTH: 4.39 m  
AREA: 20.47 m<sup>2</sup> • PERIMETER: 17.74 m

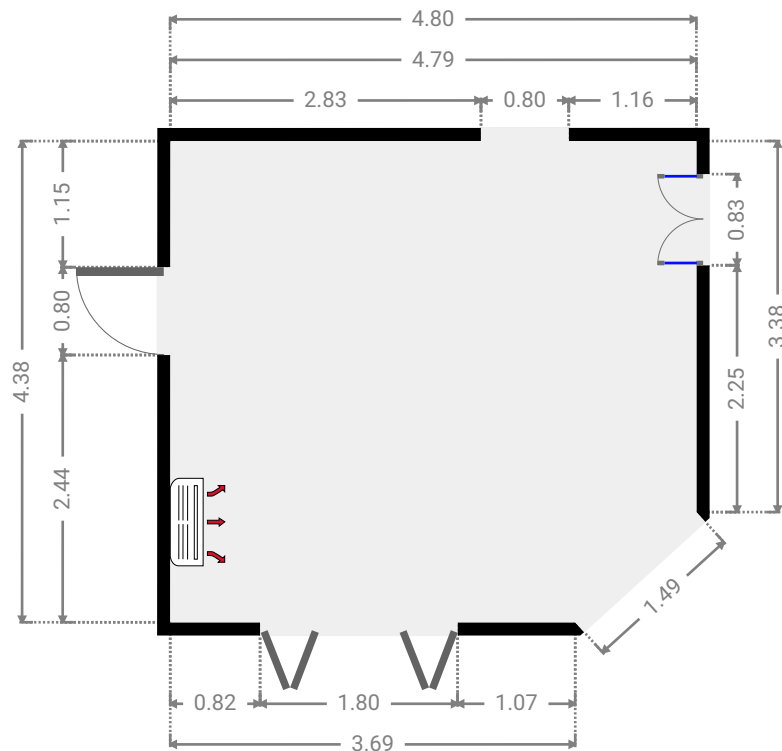
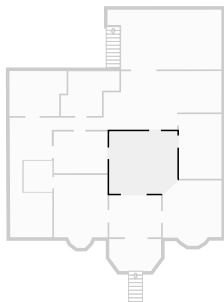



▼ **Dining Room**  
1st Floor

WIDTH: 4.14 m • LENGTH: 4.62 m  
AREA: 17.00 m<sup>2</sup> • PERIMETER: 16.16 m

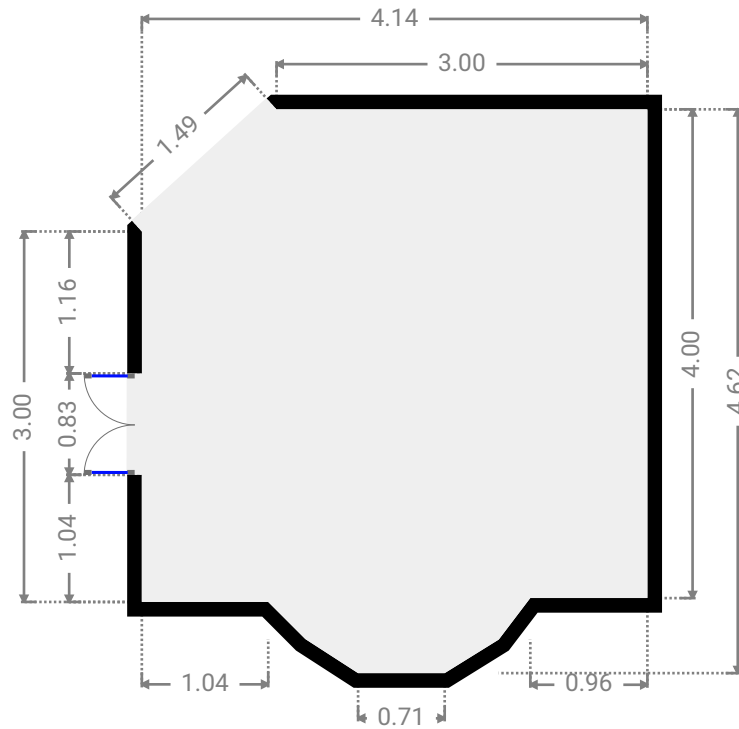
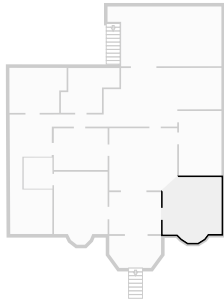

▼ **Bedroom**  
1st Floor

WIDTH: 3.00 m • LENGTH: 4.56 m  
AREA: 13.68 m<sup>2</sup> • PERIMETER: 15.12 m

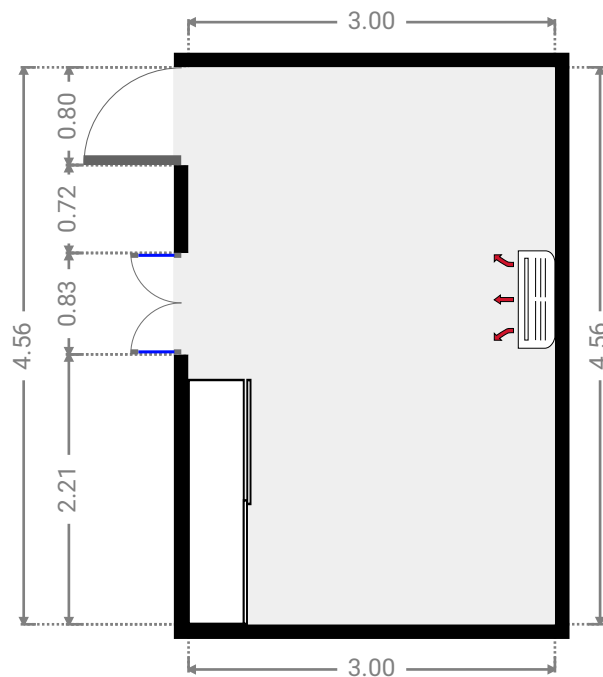
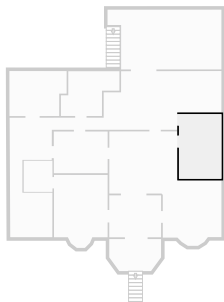

▼ **Bedroom**  
1st Floor

WIDTH: 4.04 m • LENGTH: 3.18 m  
AREA: 11.99 m<sup>2</sup> • PERIMETER: 14.42 m

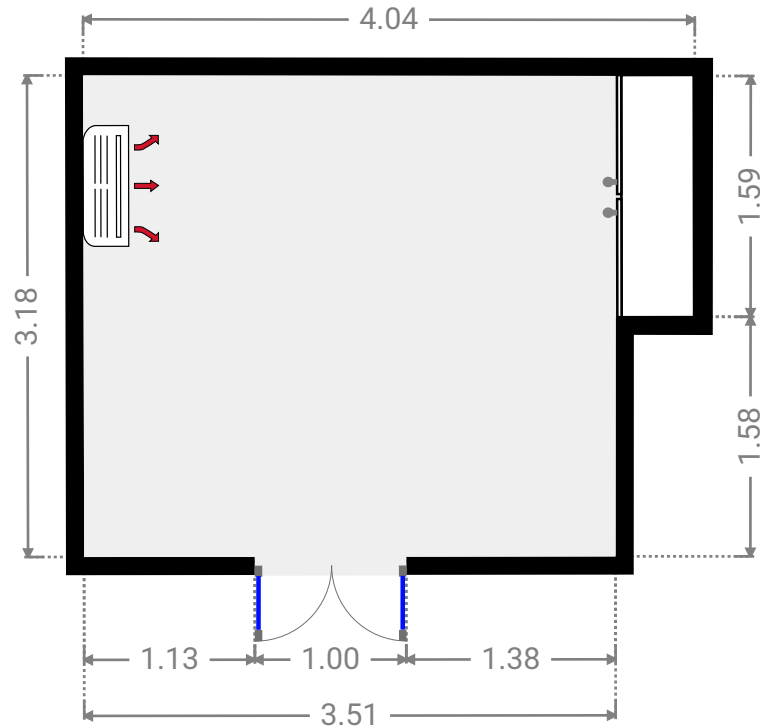
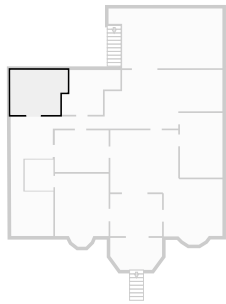

▼ **Bathroom**  
1st Floor

WIDTH: 4.13 m • LENGTH: 3.16 m  
AREA: 9.96 m<sup>2</sup> • PERIMETER: 14.58 m

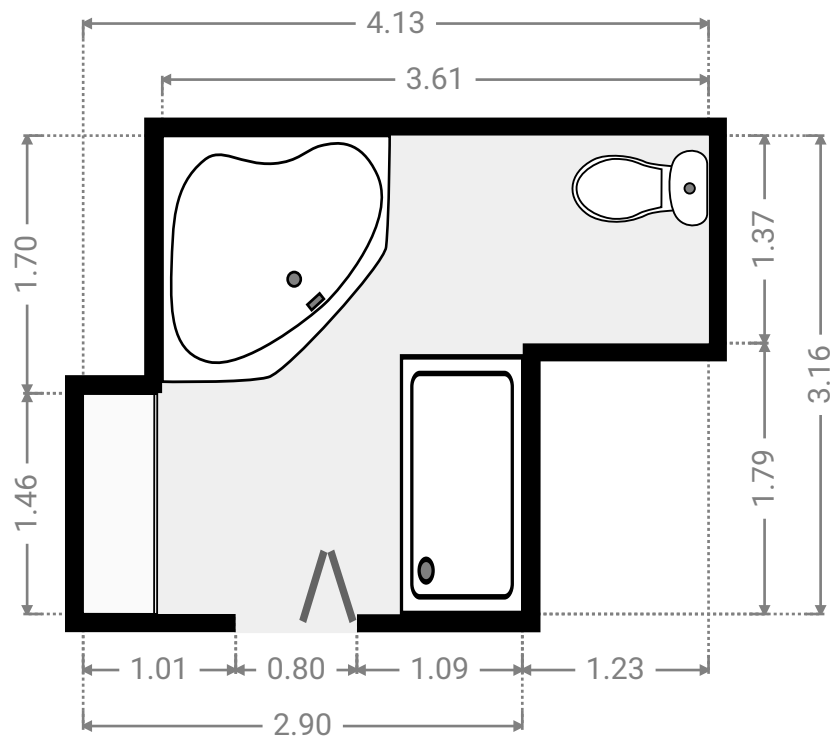
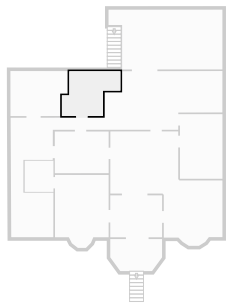

▼ **Kitchen**  
1st Floor

WIDTH: 11.86 m • LENGTH: 4.14 m  
AREA: 31.78 m<sup>2</sup> • PERIMETER: 31.96 m

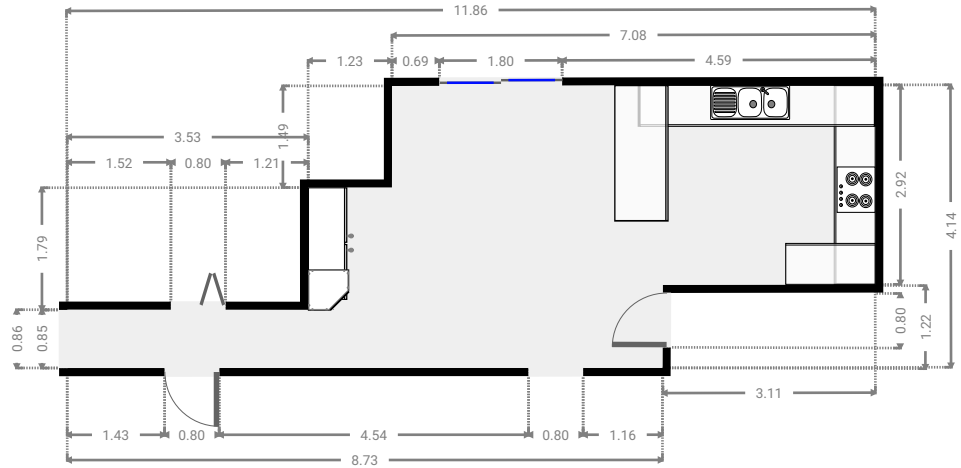
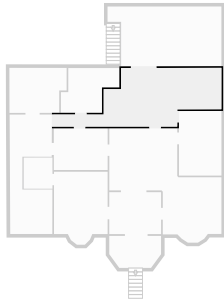

▼ **Kitchen**  
1st Floor

WIDTH: 8.04 m • LENGTH: 4.22 m  
AREA: 30.90 m<sup>2</sup> • PERIMETER: 24.52 m

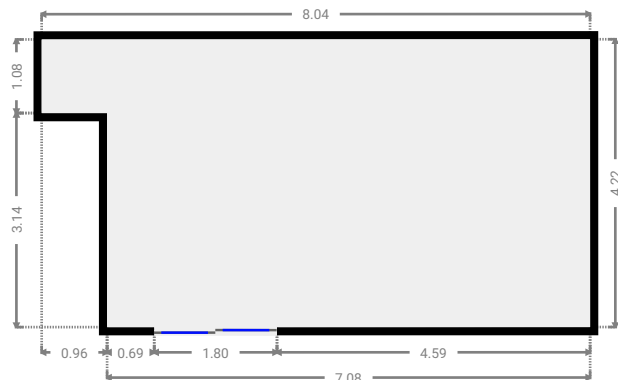
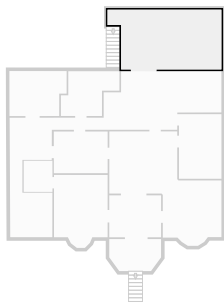

▼ Other  
1st Floor

WIDTH: 3.66 m • LENGTH: 2.26 m  
AREA: 7.58 m<sup>2</sup> • PERIMETER: 10.88 m

