

363 Farm Street

Ground Floor

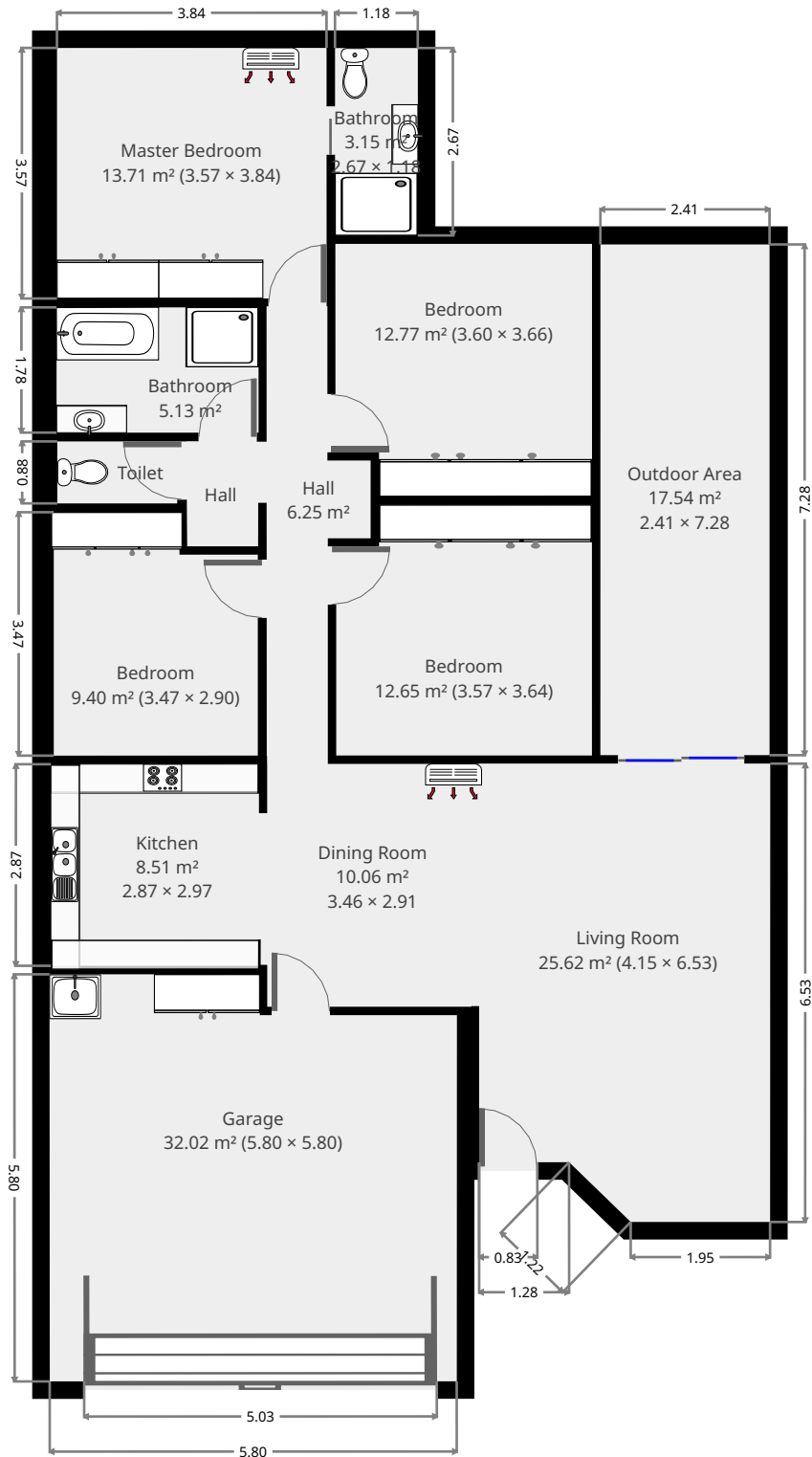

THIS FLOORPLAN IS PROVIDED WITHOUT WARRANTY OF ANY KIND. SENSOPIA DISCLAIMS ANY WARRANTY INCLUDING, WITHOUT LIMITATION, SATISFACTORY QUALITY OR ACCURACY OF DIMENSIONS.



363 Farm Street

Living Room

Width: 4.15 m
 Length: 6.53 m
 Area: 25.62 m²
 Perimeter: 20.85 m

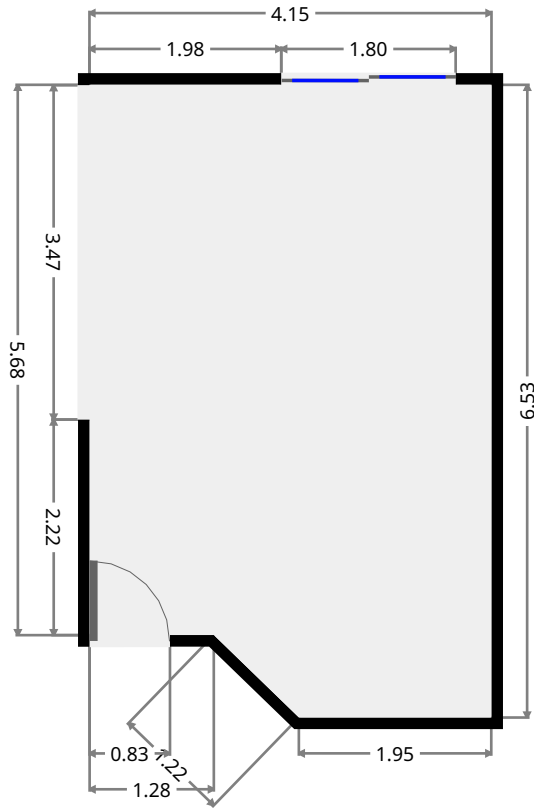
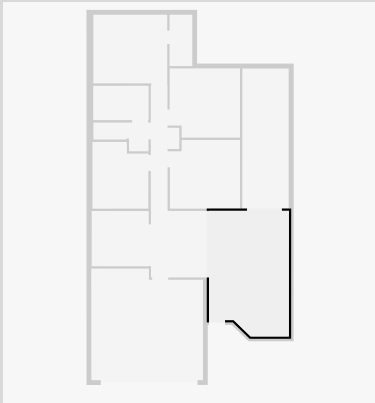

Dining Room

Width: 2.91 m
 Length: 3.46 m
 Area: 10.06 m²
 Perimeter: 12.73 m

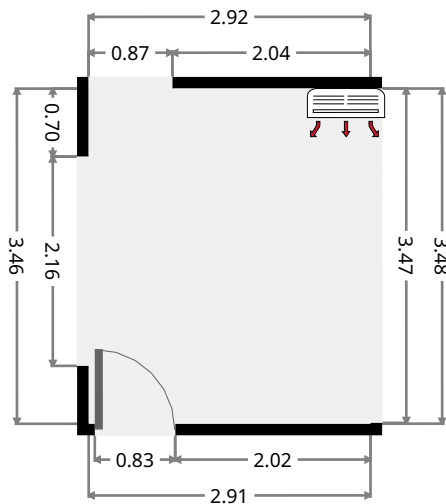
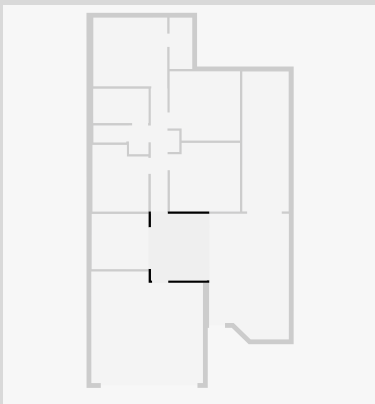

363 Farm Street

Kitchen

Width: 2.87 m
 Length: 2.97 m
 Area: 8.51 m²
 Perimeter: 11.67 m

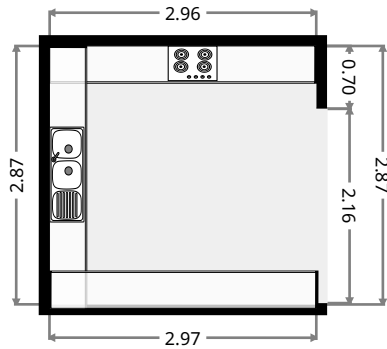
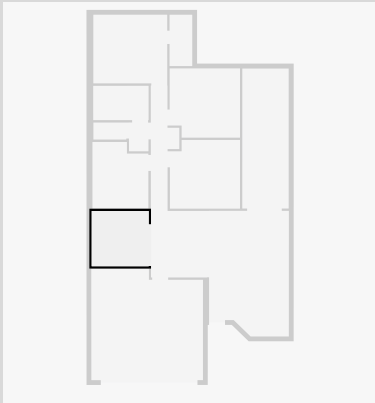

Hall

Width: 1.48 m
 Length: 6.41 m
 Area: 6.25 m²
 Perimeter: 15.77 m

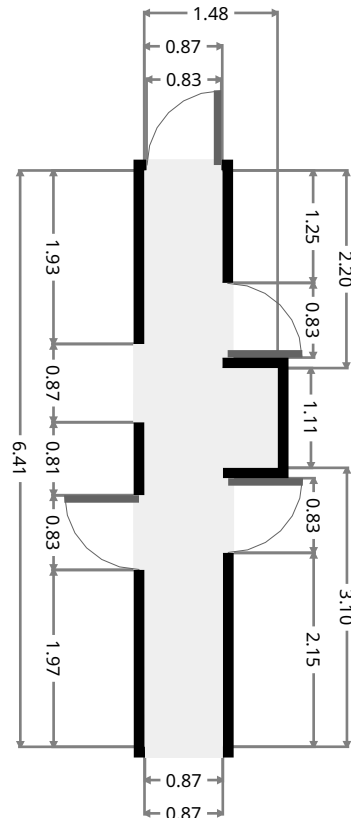
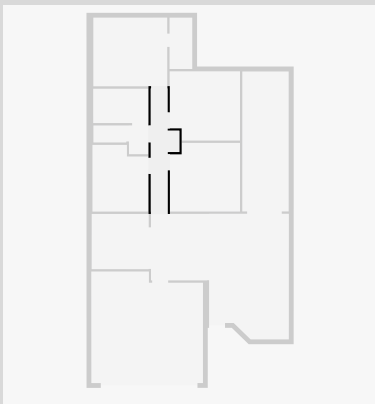

THIS FLOORPLAN IS PROVIDED WITHOUT WARRANTY OF ANY KIND. SENSOPIA DISCLAIMS ANY WARRANTY INCLUDING, WITHOUT LIMITATION, SATISFACTORY QUALITY OR ACCURACY OF DIMENSIONS.

363 Farm Street

Bedroom

Width: 2.90 m
 Length: 3.47 m
 Area: 9.40 m²
 Perimeter: 12.75 m

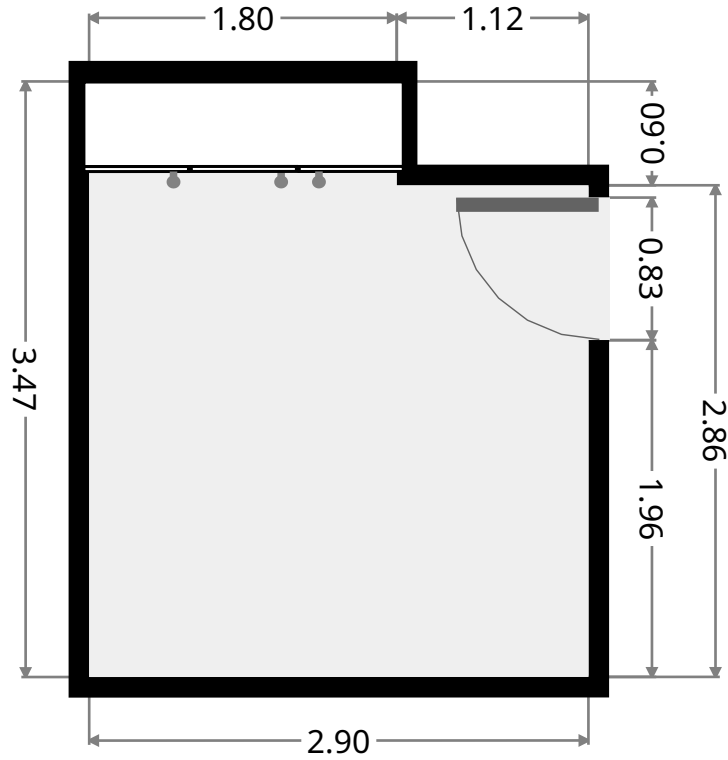
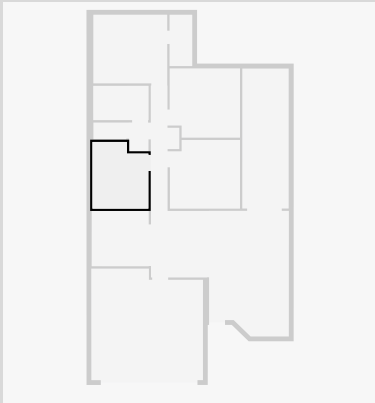

Bedroom

Width: 3.57 m
 Length: 3.64 m
 Area: 12.65 m²
 Perimeter: 14.43 m

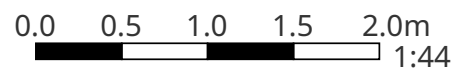
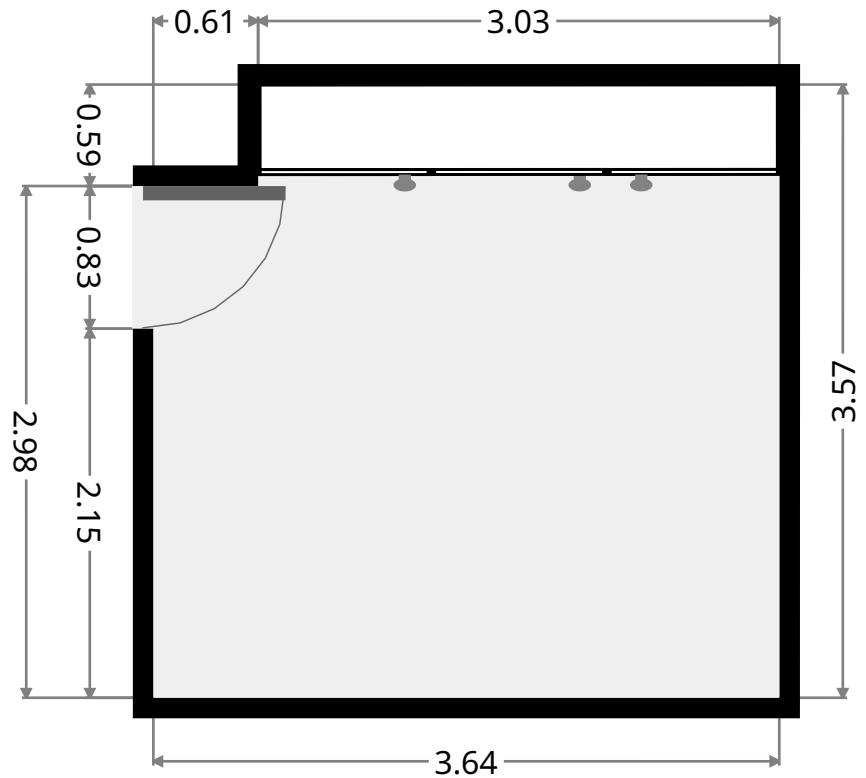
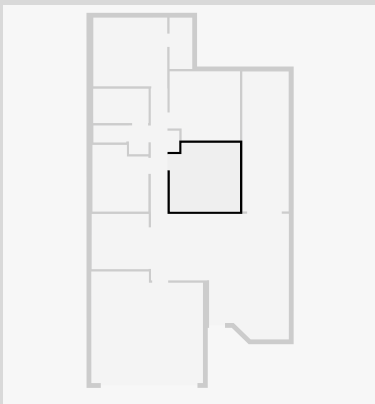

THIS FLOORPLAN IS PROVIDED WITHOUT WARRANTY OF ANY KIND. SENSOPIA DISCLAIMS ANY WARRANTY INCLUDING, WITHOUT LIMITATION, SATISFACTORY QUALITY OR ACCURACY OF DIMENSIONS.

363 Farm Street

Bedroom

Width: 3.60 m
 Length: 3.66 m
 Area: 12.77 m²
 Perimeter: 14.51 m

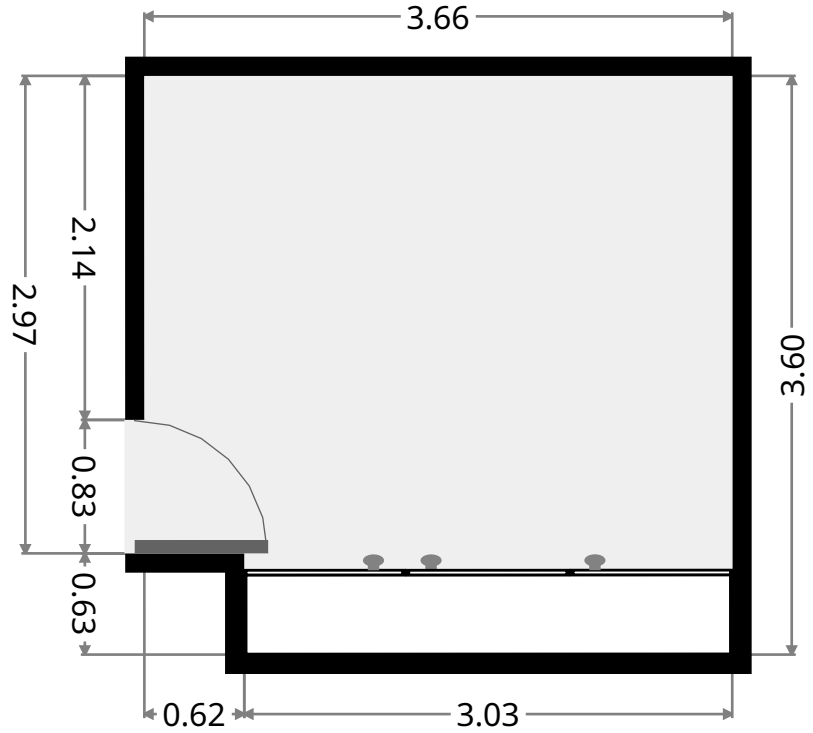
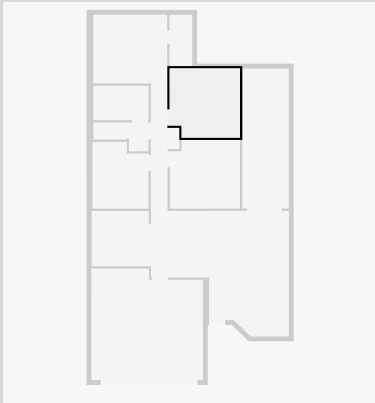

Master Bedroom

Width: 3.57 m
 Length: 3.84 m
 Area: 13.71 m²
 Perimeter: 14.82 m

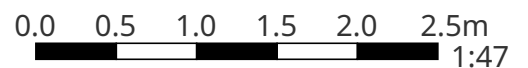
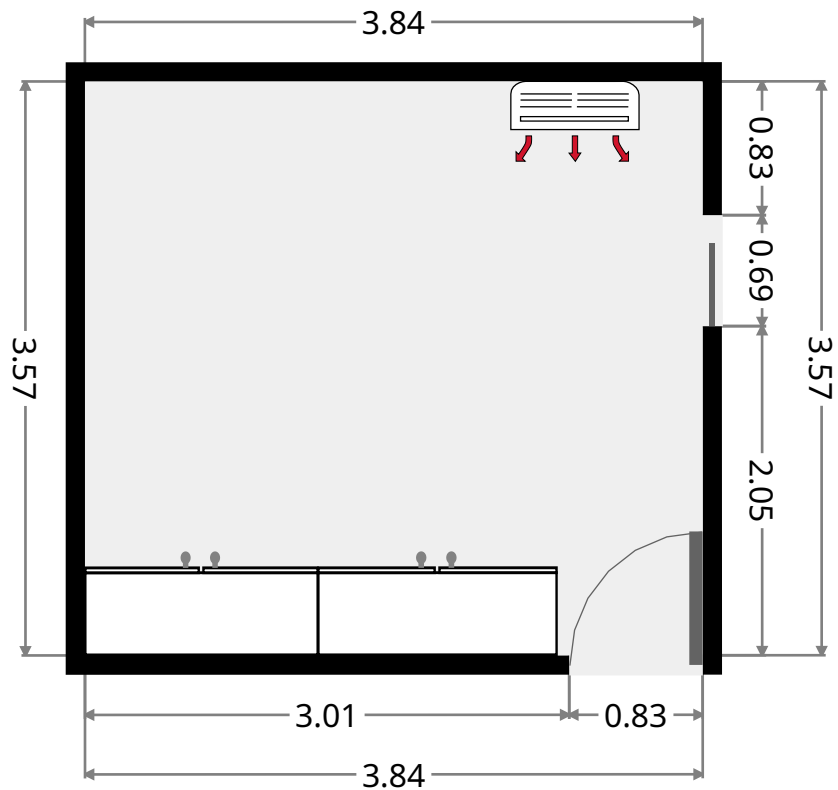
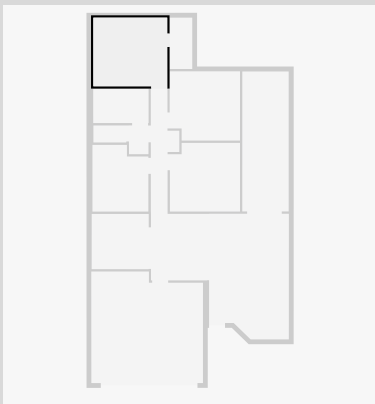

THIS FLOORPLAN IS PROVIDED WITHOUT WARRANTY OF ANY KIND. SENSOPIA DISCLAIMS ANY WARRANTY INCLUDING, WITHOUT LIMITATION, SATISFACTORY QUALITY OR ACCURACY OF DIMENSIONS.

363 Farm Street

Bathroom

Width: 1.18 m
 Length: 2.67 m
 Area: 3.15 m²
 Perimeter: 7.70 m

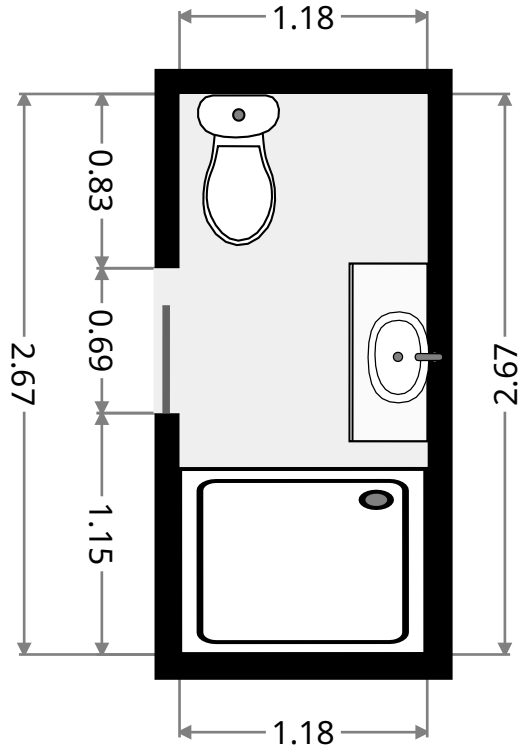
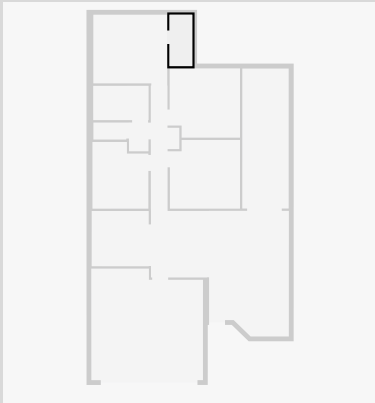

Bathroom

Width: 1.78 m
 Length: 2.88 m
 Area: 5.13 m²
 Perimeter: 9.32 m

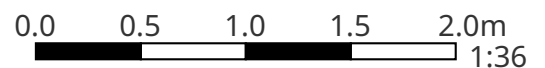
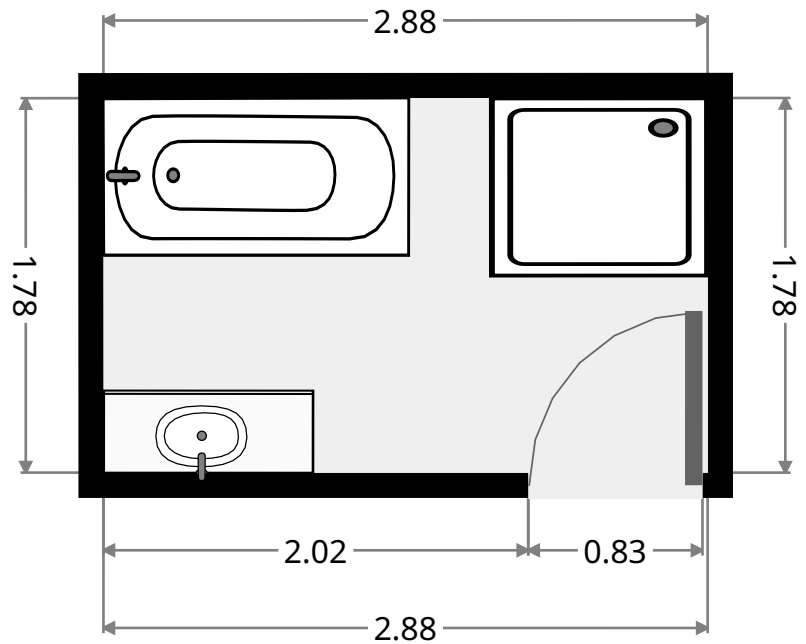
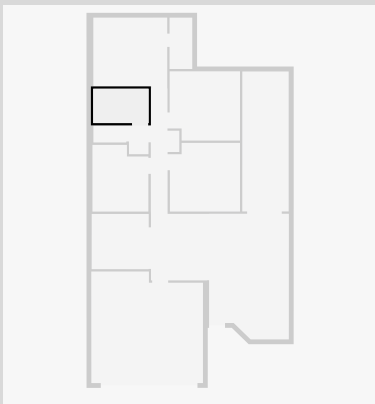

THIS FLOORPLAN IS PROVIDED WITHOUT WARRANTY OF ANY KIND. SENSOPIA DISCLAIMS ANY WARRANTY INCLUDING, WITHOUT LIMITATION, SATISFACTORY QUALITY OR ACCURACY OF DIMENSIONS.

363 Farm Street

Toilet

Width: 0.88 m
Length: 1.70 m
Area: 1.51 m²
Perimeter: 5.18 m

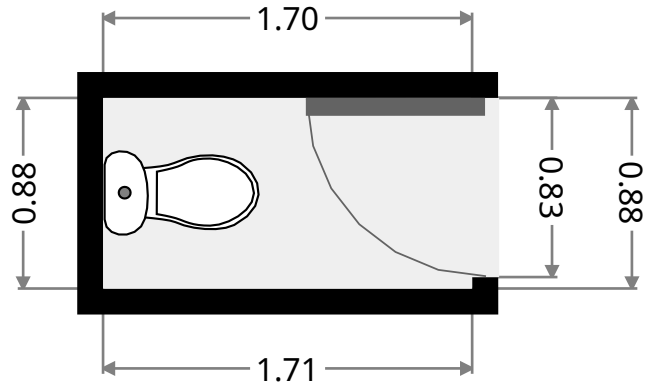
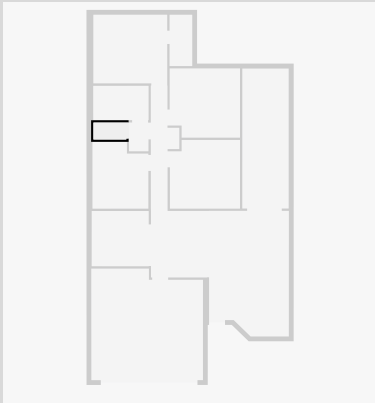

Hall

Width: 1.03 m
Length: 1.50 m
Area: 1.52 m²
Perimeter: 5.03 m

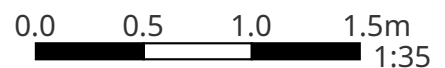
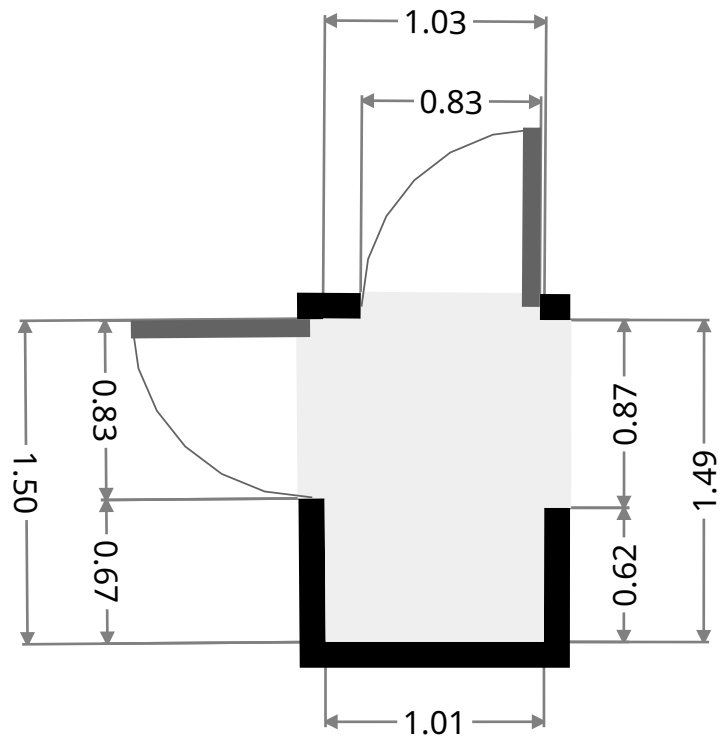
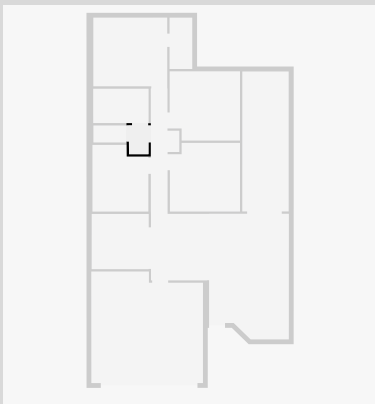

363 Farm Street

Garage

Width: 5.80 m
Length: 5.80 m
Area: 32.02 m²
Perimeter: 23.20 m

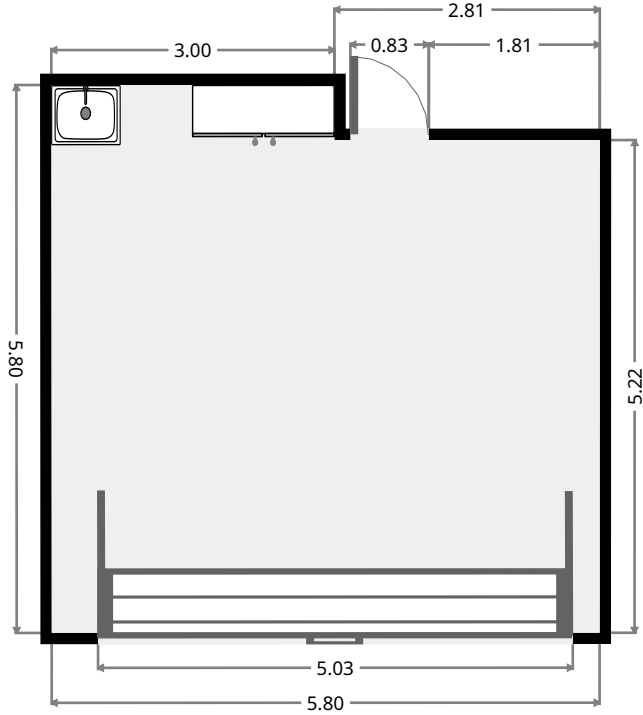
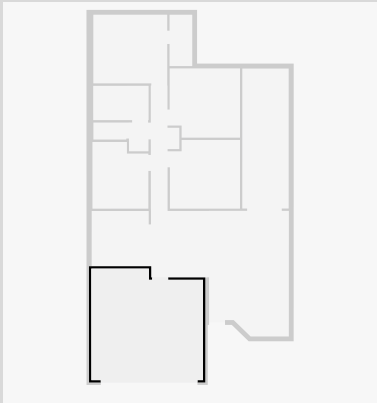

Outdoor Area

Width: 2.41 m
Length: 7.28 m
Area: 17.54 m²
Perimeter: 19.37 m

