

# 351 Rockonia Road

**SUBMITTED BY**  
Ray White Rockhampton Casey  
stockers@cqoz.com

---

**CREATED ON**  
2021-11-15

---

**Floors**  
2

---

▼ Ground Floor

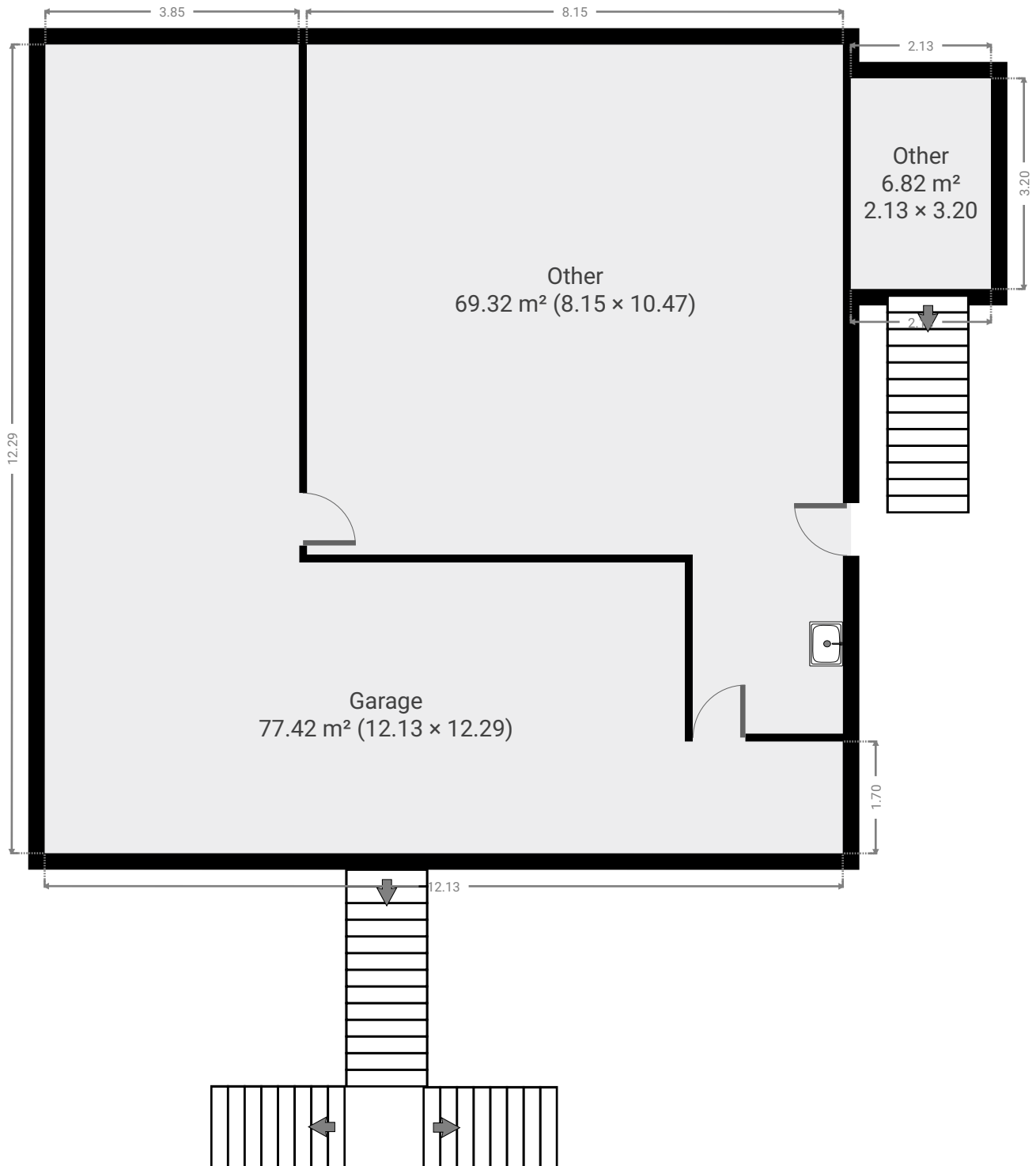

▼ **Garage**  
Ground Floor

WIDTH: 12.29 m • LENGTH: 12.13 m  
AREA: 77.42 m<sup>2</sup> • PERIMETER: 48.82 m

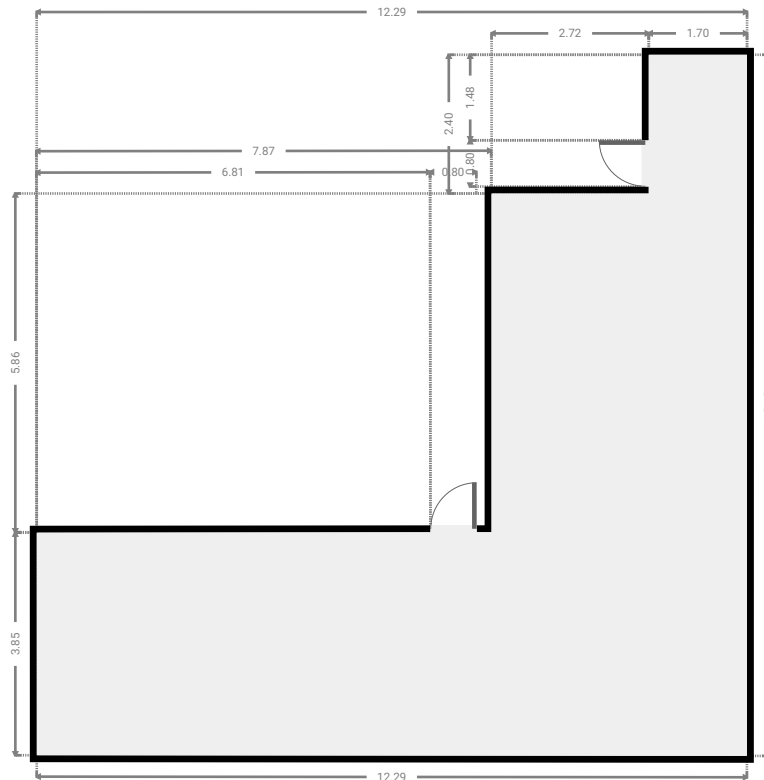
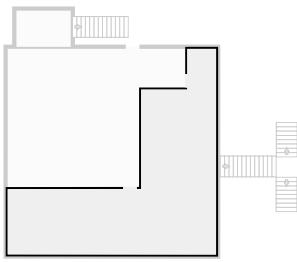

▼ **Other**  
Ground Floor

WIDTH: 10.47 m • LENGTH: 8.15 m  
AREA: 69.32 m<sup>2</sup> • PERIMETER: 37.23 m

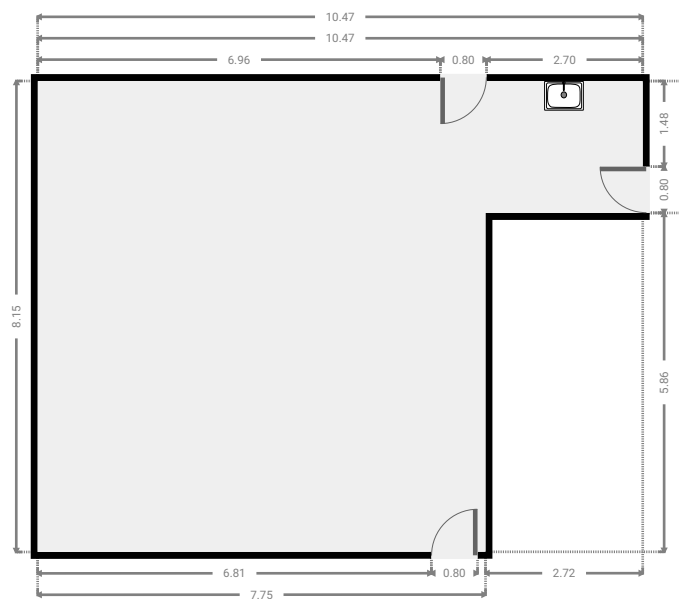
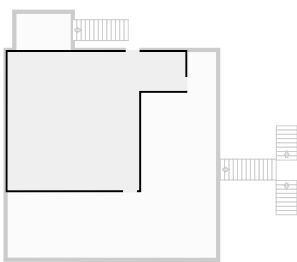

▼ Other  
Ground Floor

WIDTH: 3.20 m • LENGTH: 2.13 m  
AREA: 6.82 m<sup>2</sup> • PERIMETER: 10.66 m

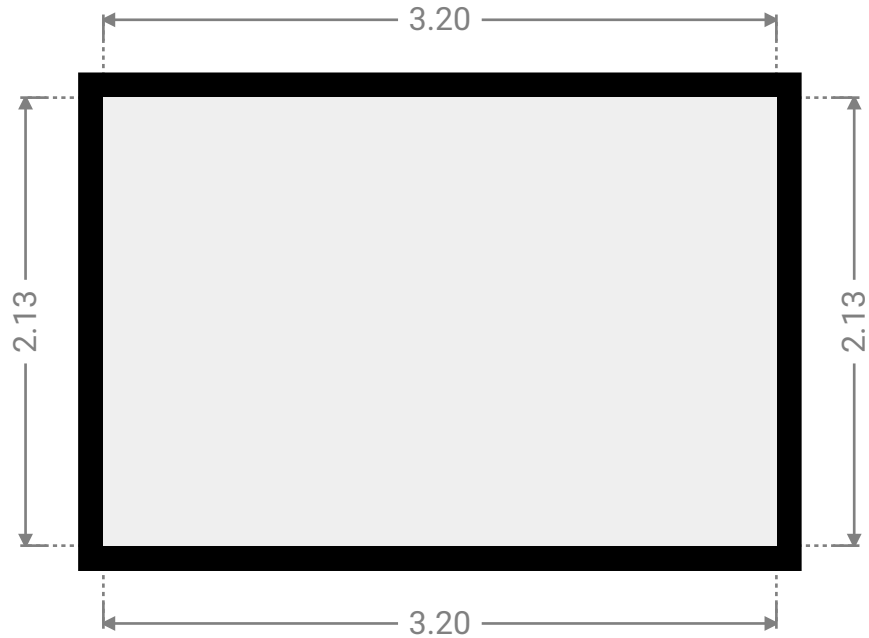
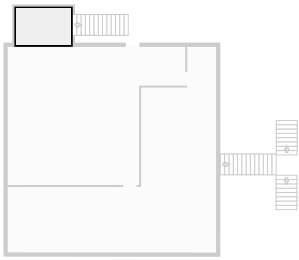

▼ 1st Floor

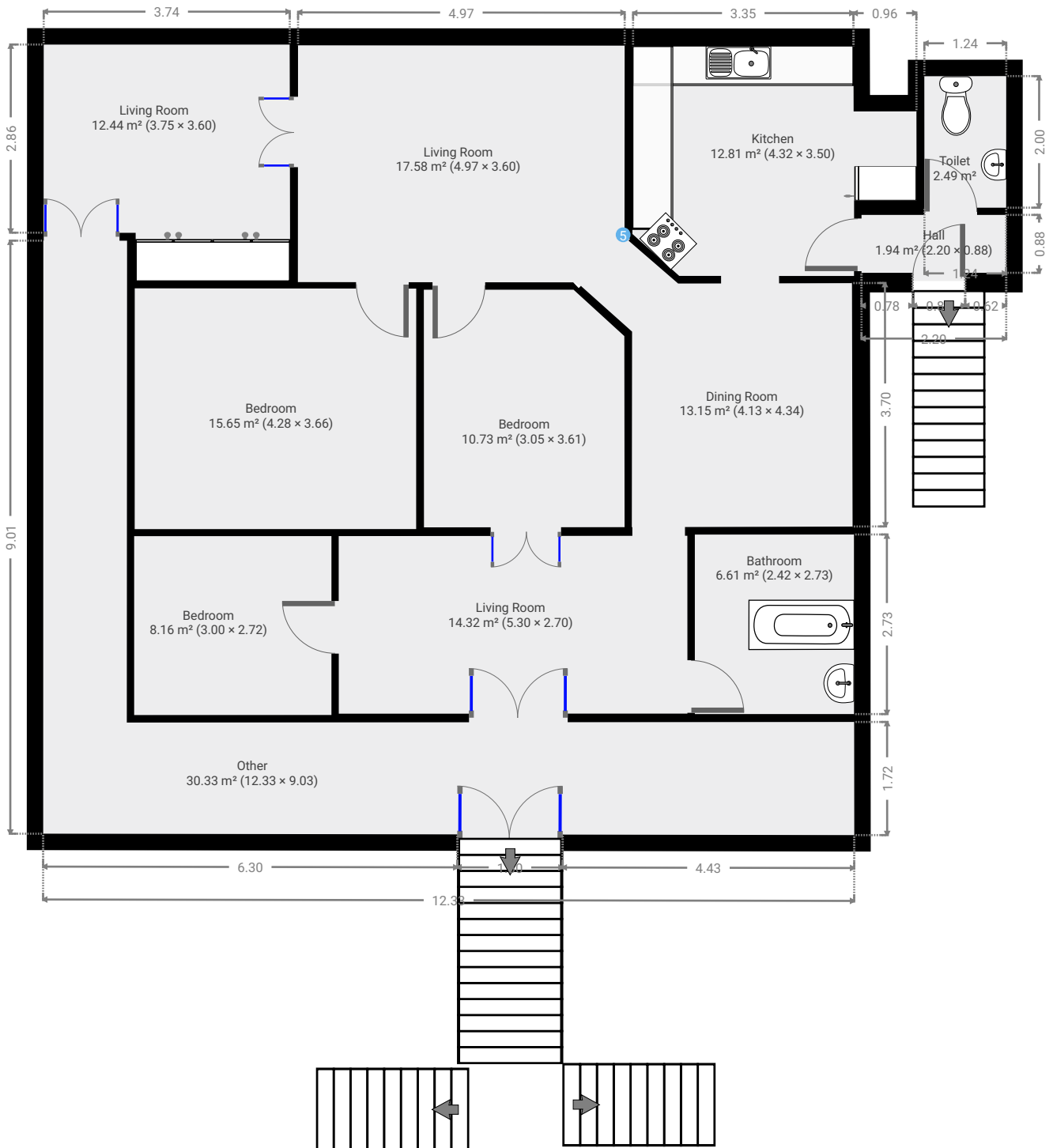

▼ Living Room  
1st Floor

WIDTH: 3.60 m • LENGTH: 3.75 m  
AREA: 12.44 m<sup>2</sup> • PERIMETER: 14.69 m

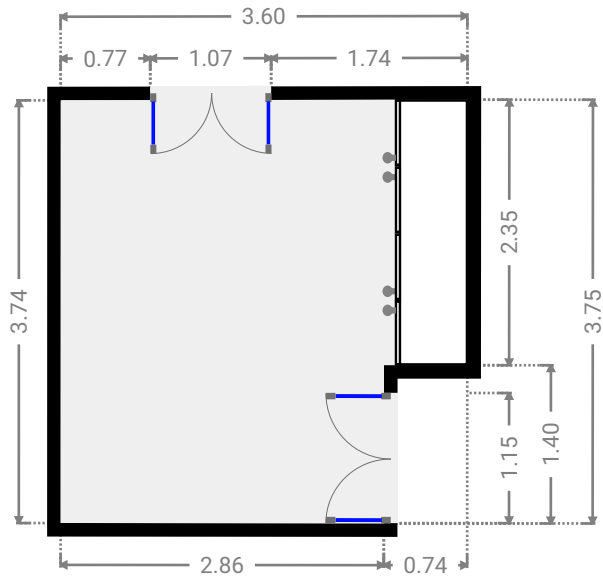
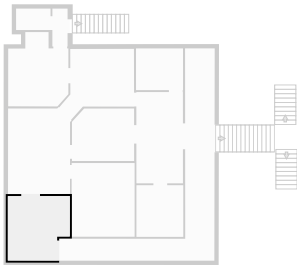

▼ Living Room  
1st Floor

WIDTH: 3.60 m • LENGTH: 4.97 m  
AREA: 17.58 m<sup>2</sup> • PERIMETER: 16.68 m

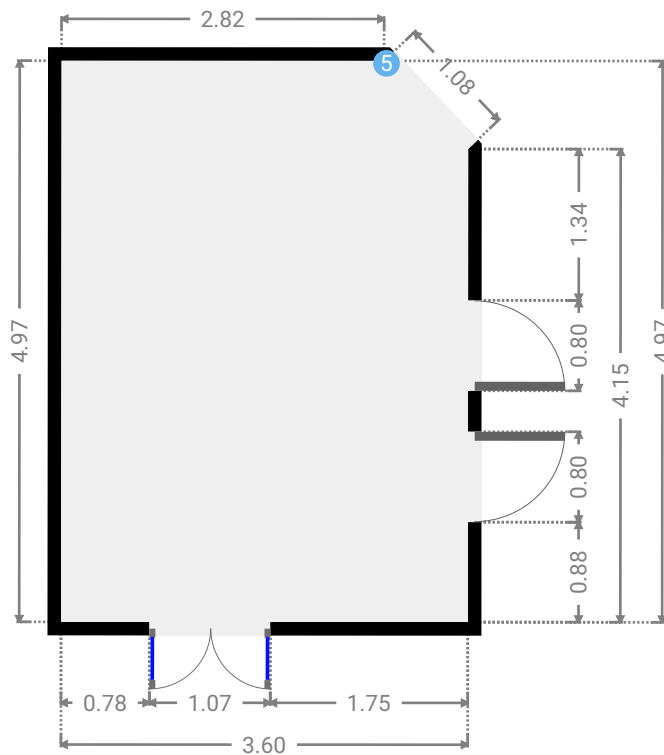
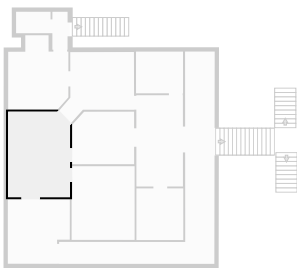

▼ Living Room/1st Floor

5 OPENING

Height  
0.00 m



▼ Bedroom  
1st Floor

WIDTH: 3.66 m • LENGTH: 4.28 m  
AREA: 15.65 m<sup>2</sup> • PERIMETER: 15.87 m

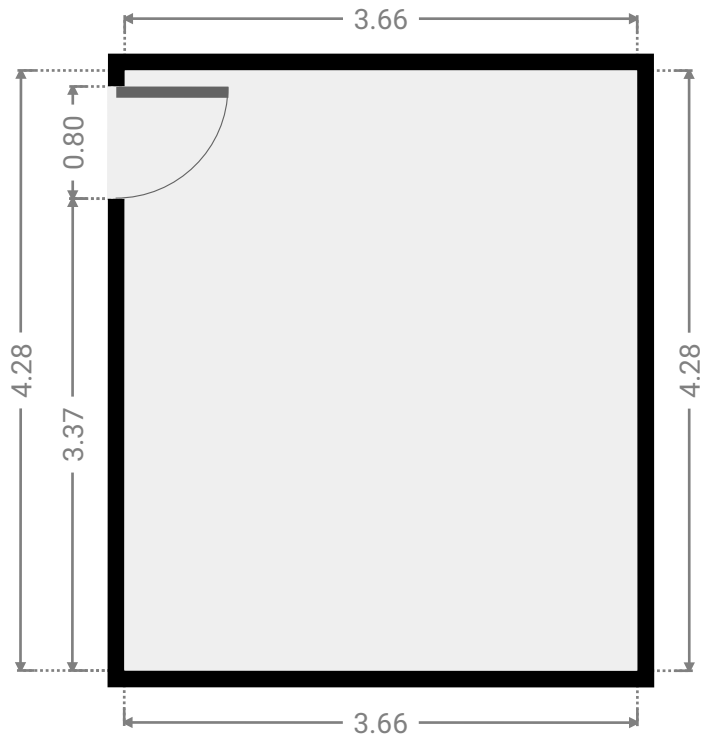
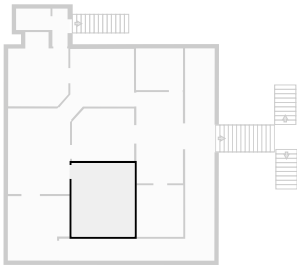

▼ Bedroom  
1st Floor

WIDTH: 3.61 m • LENGTH: 3.05 m  
AREA: 10.73 m<sup>2</sup> • PERIMETER: 12.89 m

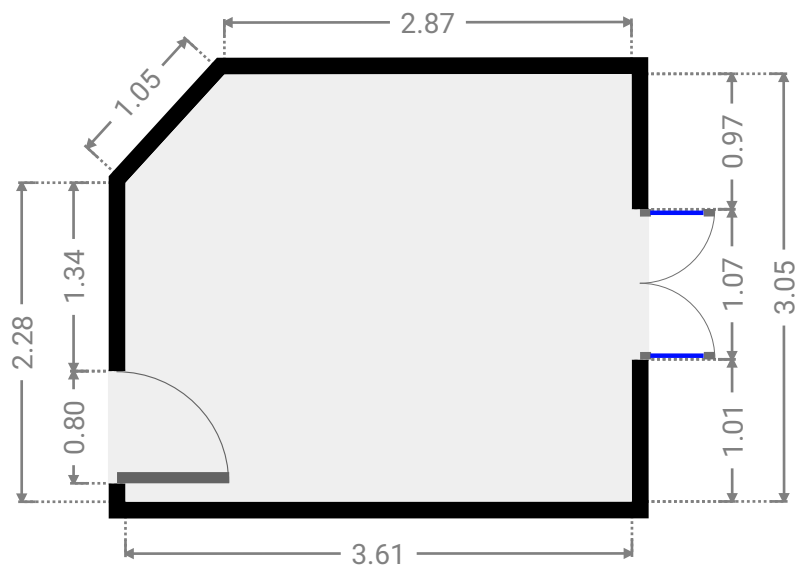
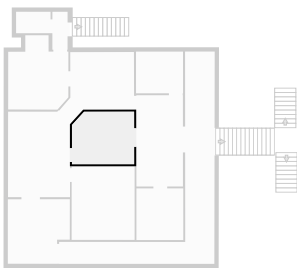



▼ Living Room  
1st Floor

WIDTH: 2.70 m • LENGTH: 5.30 m  
AREA: 14.32 m<sup>2</sup> • PERIMETER: 16.00 m

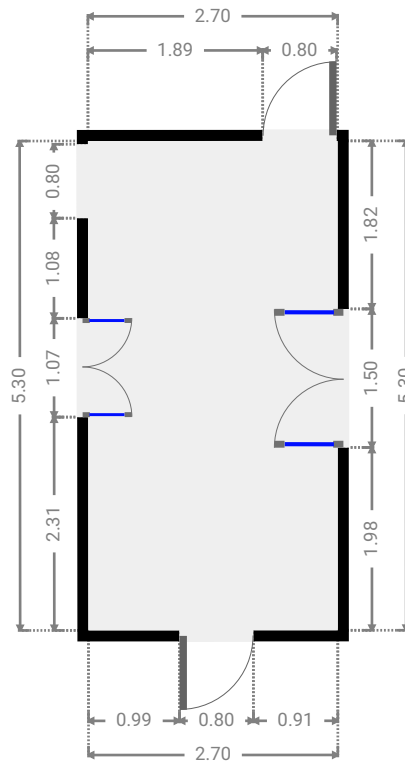
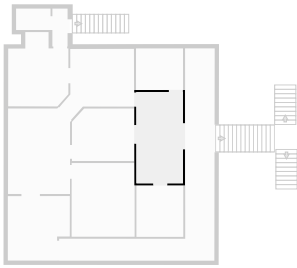

▼ Bedroom  
1st Floor

WIDTH: 2.72 m • LENGTH: 3.00 m  
AREA: 8.16 m<sup>2</sup> • PERIMETER: 11.44 m

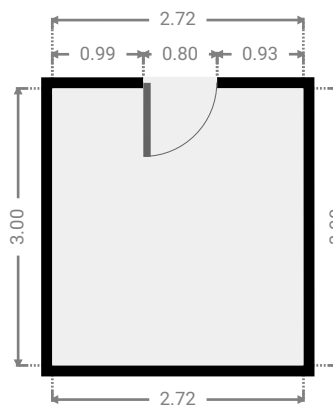
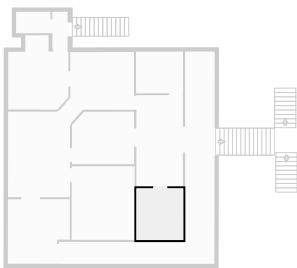

▼ **Bathroom**  
1st Floor

WIDTH: 2.73 m • LENGTH: 2.42 m  
AREA: 6.61 m<sup>2</sup> • PERIMETER: 10.30 m

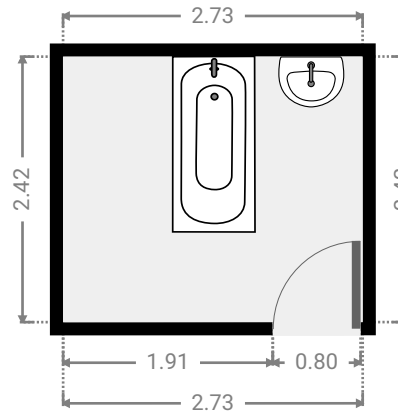
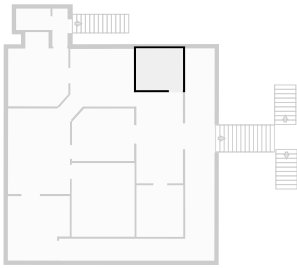

▼ **Dining Room**  
1st Floor

WIDTH: 4.34 m • LENGTH: 4.13 m  
AREA: 13.15 m<sup>2</sup> • PERIMETER: 15.69 m

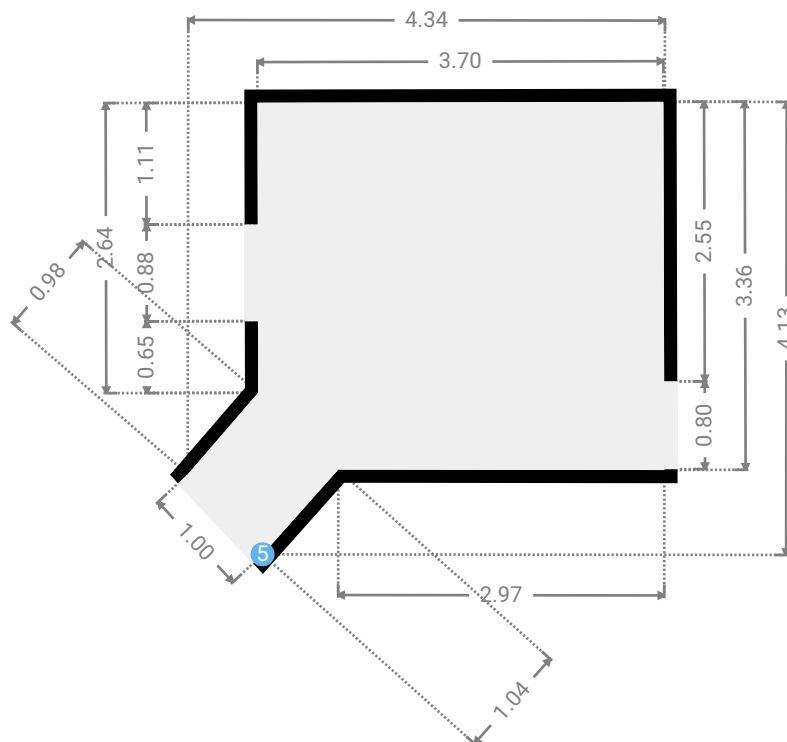
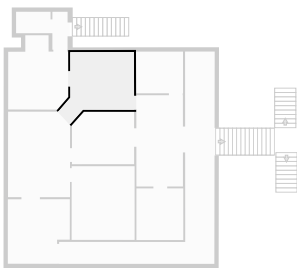

▼ Kitchen  
1st Floor

WIDTH: 3.50 m • LENGTH: 4.32 m  
AREA: 12.81 m<sup>2</sup> • PERIMETER: 15.22 m

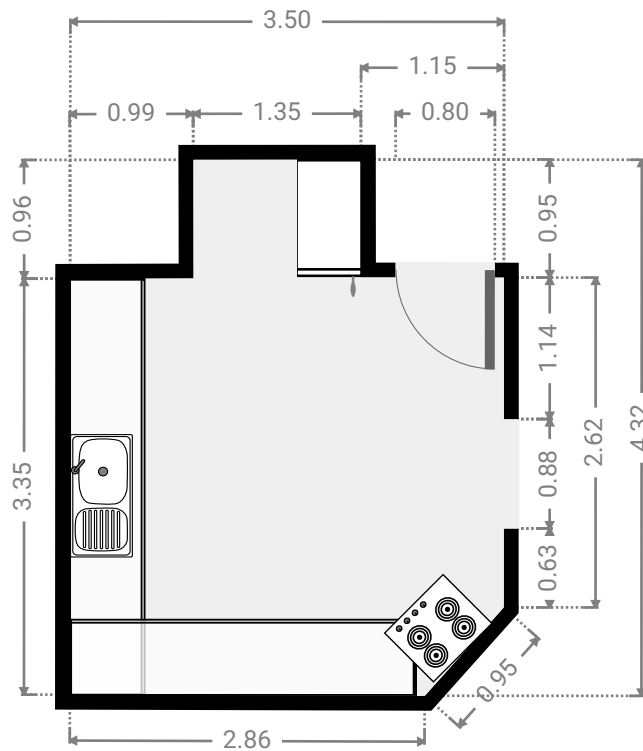
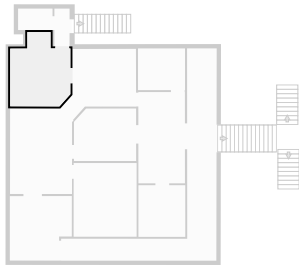

▼ Hall  
1st Floor

WIDTH: 0.88 m • LENGTH: 2.20 m  
AREA: 1.94 m<sup>2</sup> • PERIMETER: 6.16 m

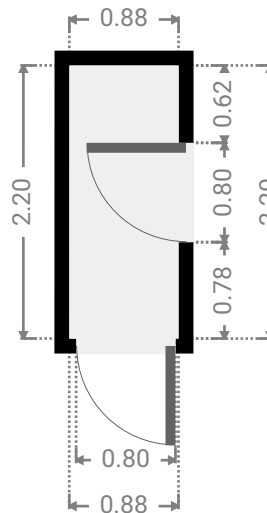
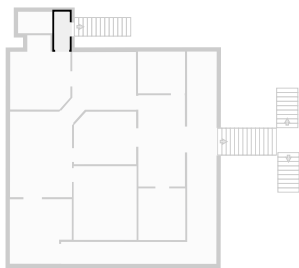

▼ Toilet  
1st Floor

WIDTH: 2.00 m • LENGTH: 1.24 m  
AREA: 2.49 m<sup>2</sup> • PERIMETER: 6.48 m

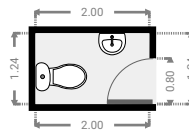
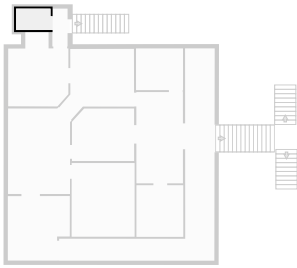

▼ Other  
1st Floor

WIDTH: 9.03 m • LENGTH: 12.33 m  
AREA: 30.33 m<sup>2</sup> • PERIMETER: 42.72 m

