

350 East Street

Created on
2021-03-30

Floors
2

▼ Ground Floor

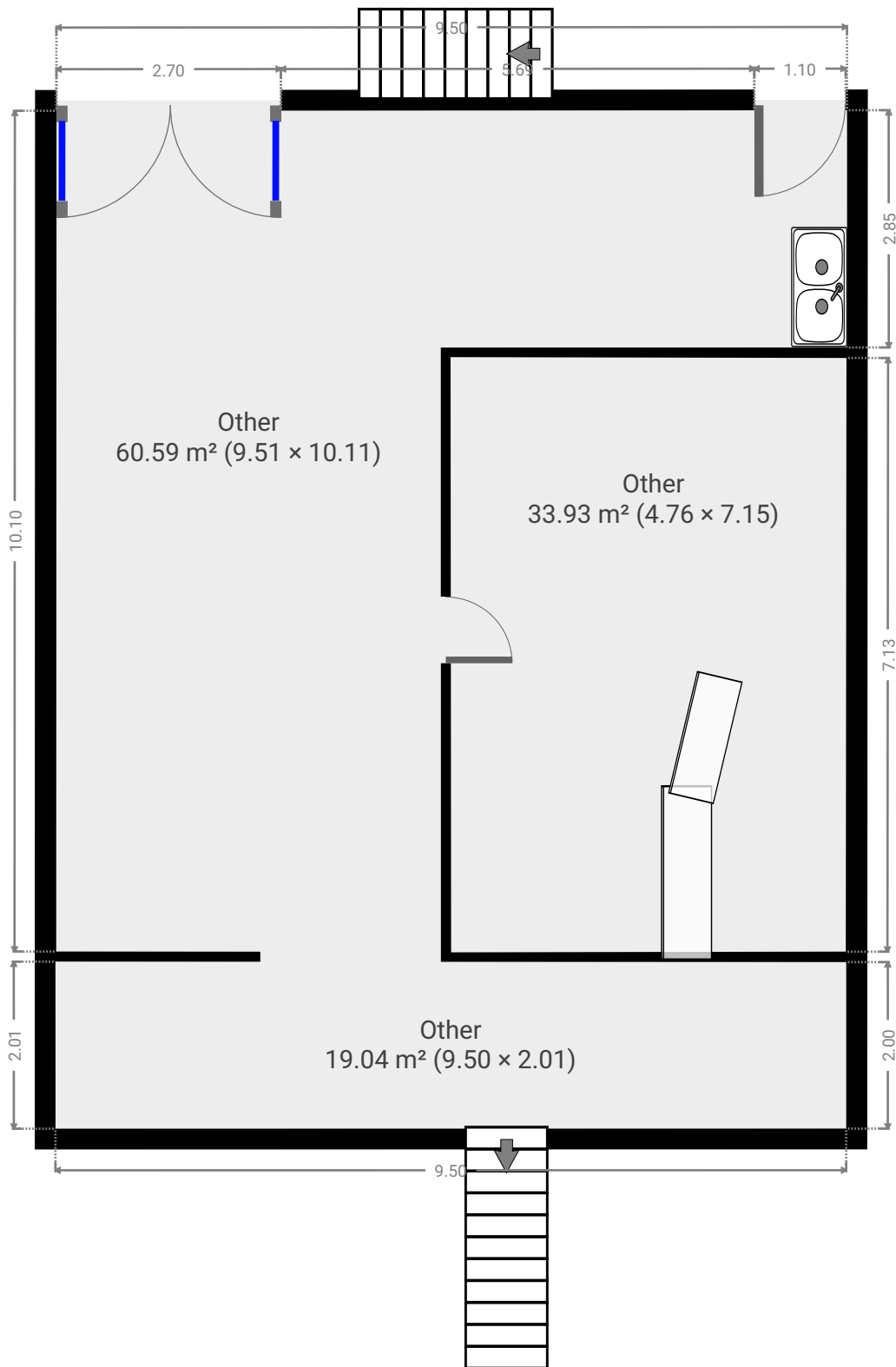

▼ Other
Ground Floor

WIDTH: 9.53 m • LENGTH: 10.11 m
AREA: 60.59 m² • PERIMETER: 39.22 m

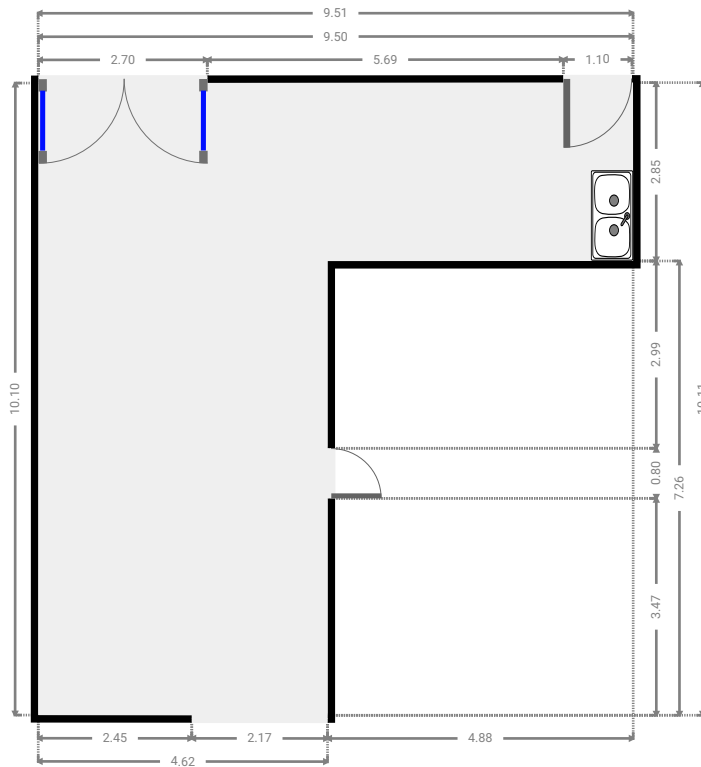
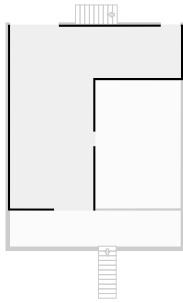

▼ Other
Ground Floor

WIDTH: 4.79 m • LENGTH: 7.15 m
AREA: 33.93 m² • PERIMETER: 23.79 m

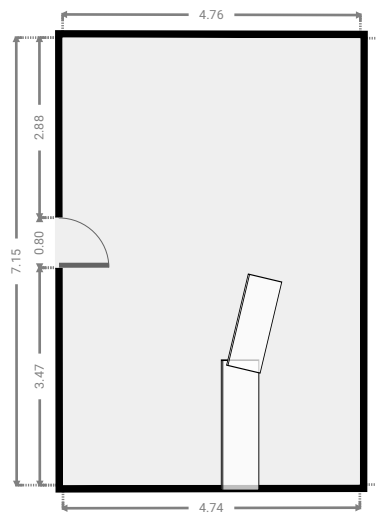
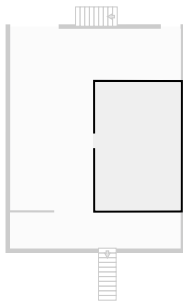

▼ Other
Ground Floor

WIDTH: 9.50 m • LENGTH: 2.01 m
AREA: 19.04 m² • PERIMETER: 23.01 m

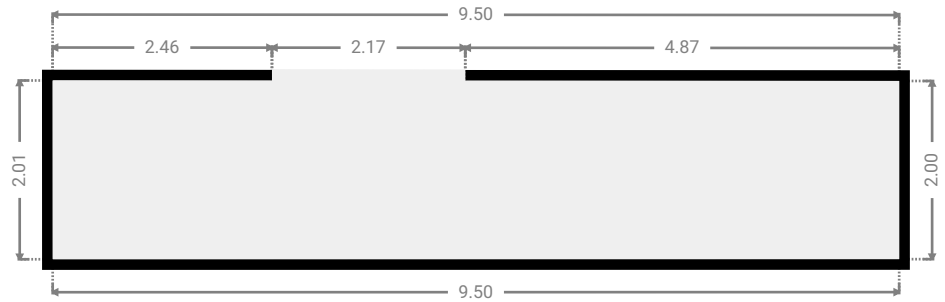
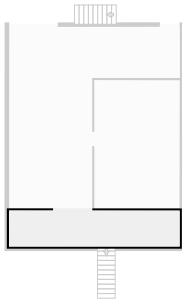

▼ 1st Floor

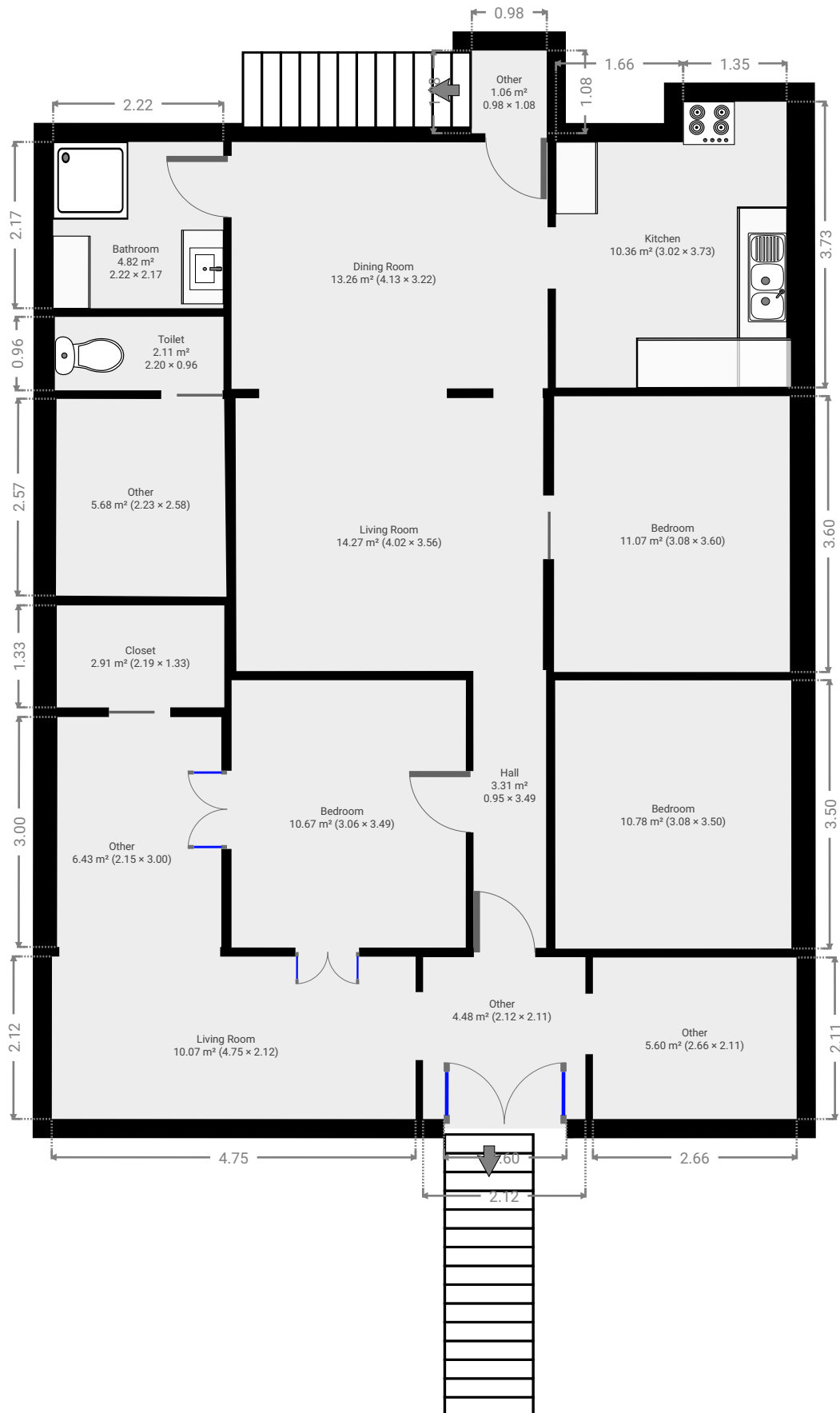

▼ Living Room
1st Floor

WIDTH: 4.75 m • LENGTH: 2.12 m
AREA: 10.07 m² • PERIMETER: 13.74 m

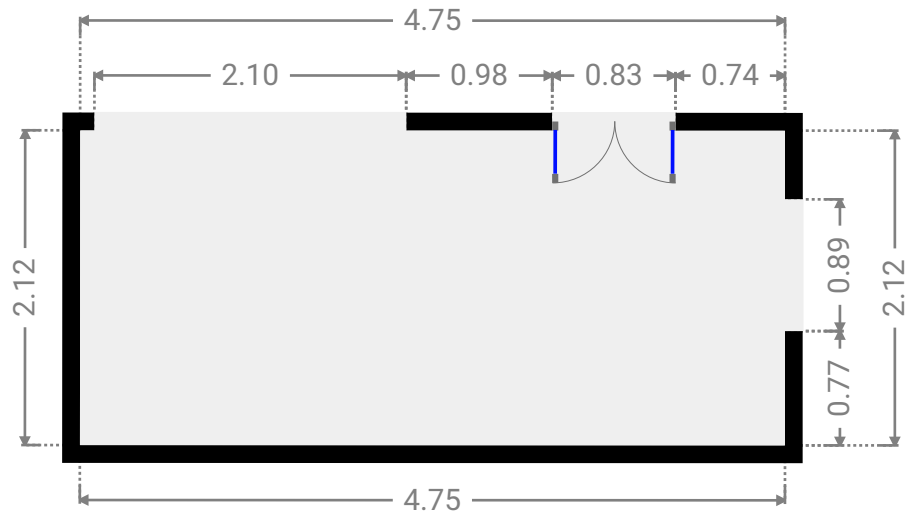
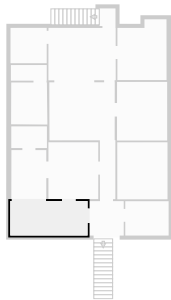

▼ Other
1st Floor

WIDTH: 2.12 m • LENGTH: 2.11 m
AREA: 4.48 m² • PERIMETER: 8.46 m

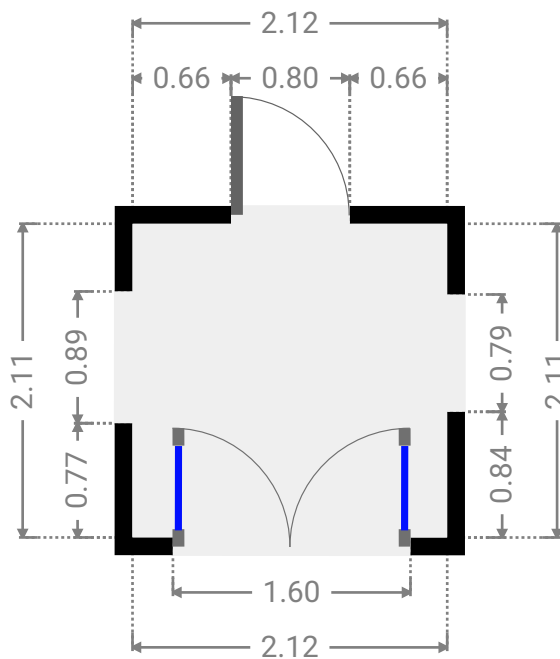
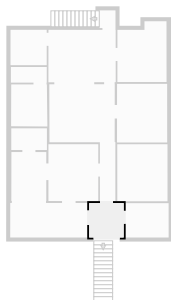

▼ **Other**
1st Floor

WIDTH: 2.66 m • LENGTH: 2.11 m
AREA: 5.60 m² • PERIMETER: 9.53 m

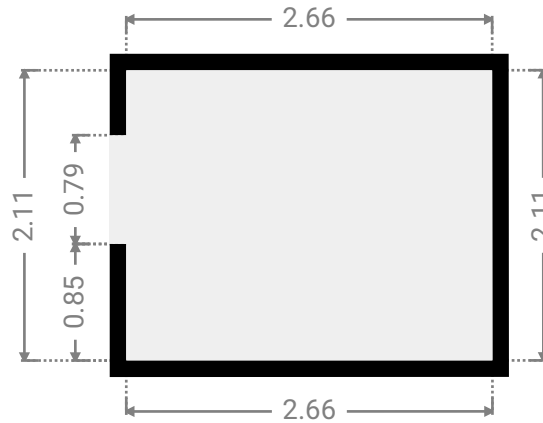
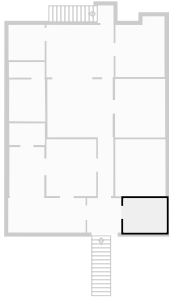

▼ **Hall**
1st Floor

WIDTH: 0.95 m • LENGTH: 3.49 m
AREA: 3.31 m² • PERIMETER: 8.88 m

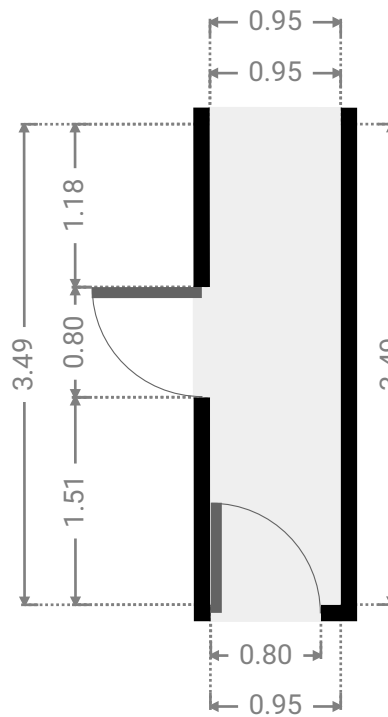
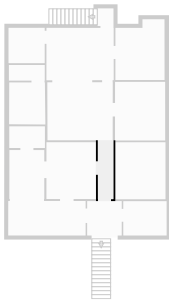

▼ **Bedroom**
1st Floor

WIDTH: 3.08 m • LENGTH: 3.50 m
AREA: 10.78 m² • PERIMETER: 13.16 m

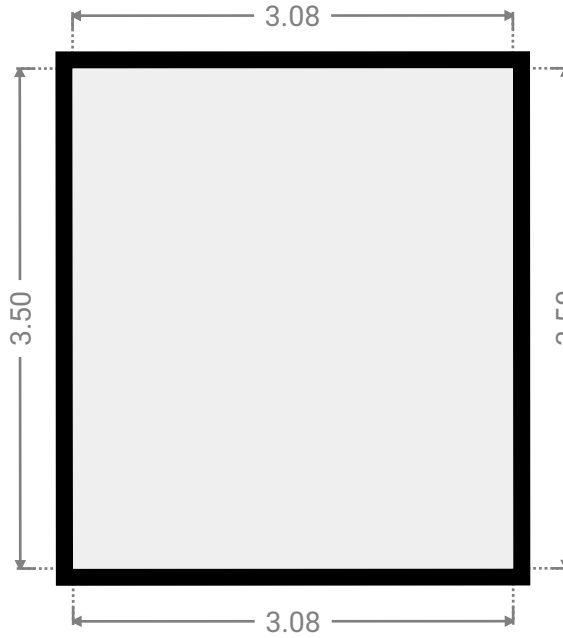
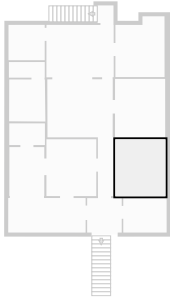

▼ **Bedroom**
1st Floor

WIDTH: 3.06 m • LENGTH: 3.49 m
AREA: 10.67 m² • PERIMETER: 13.09 m

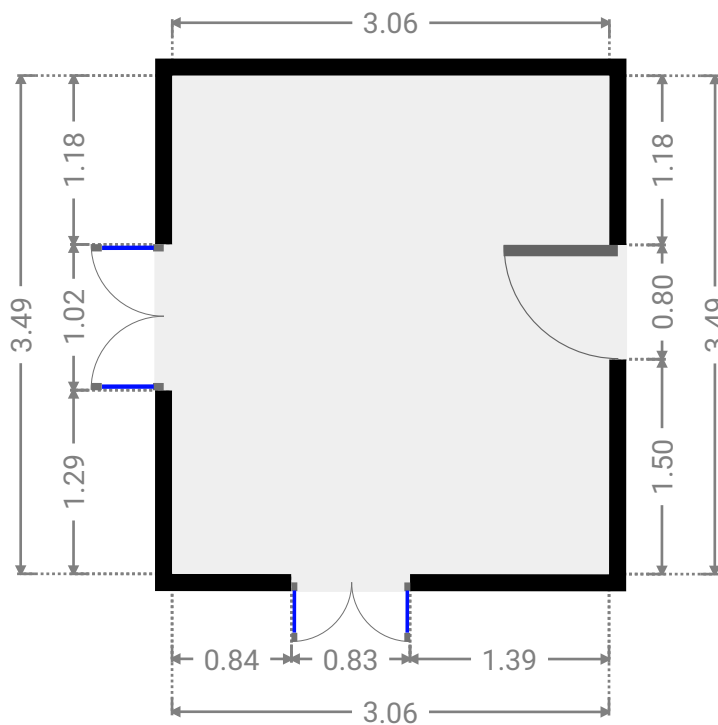
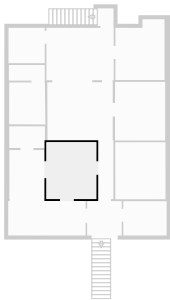

▼ Other
1st Floor

WIDTH: 2.15 m • LENGTH: 3.00 m
AREA: 6.43 m² • PERIMETER: 10.29 m

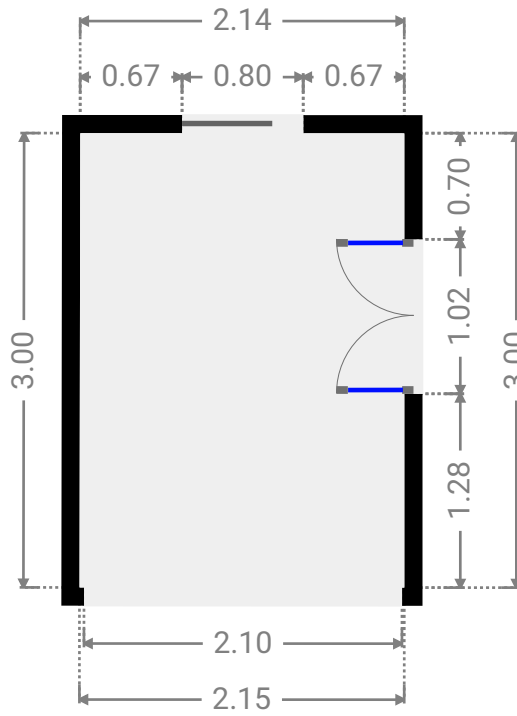
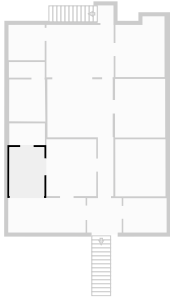

▼ Closet
1st Floor

WIDTH: 2.19 m • LENGTH: 1.33 m
AREA: 2.91 m² • PERIMETER: 7.04 m

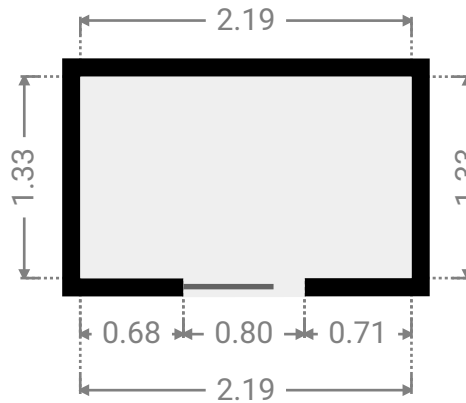
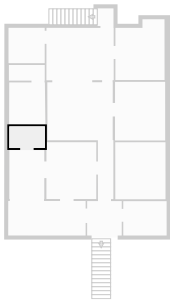

▼ Living Room
1st Floor

WIDTH: 4.02 m • LENGTH: 3.56 m
AREA: 14.27 m² • PERIMETER: 15.14 m

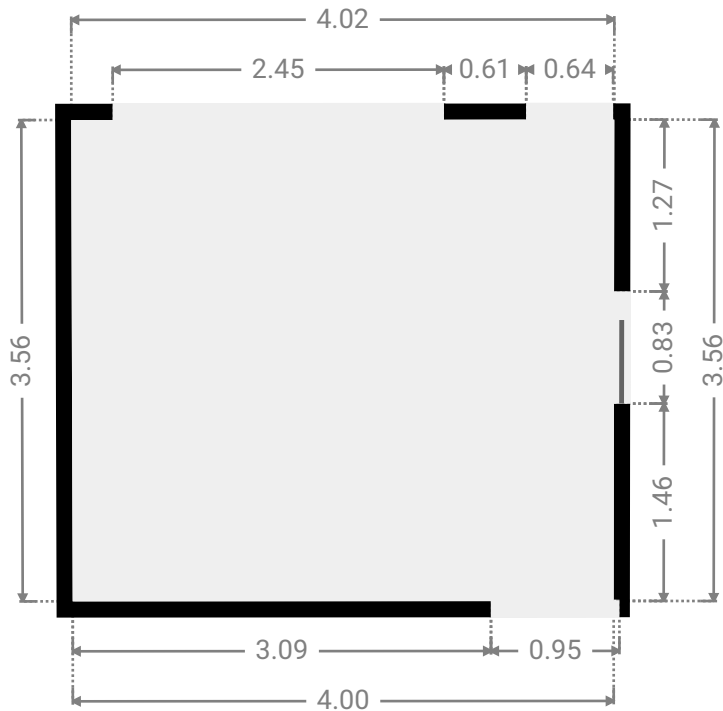
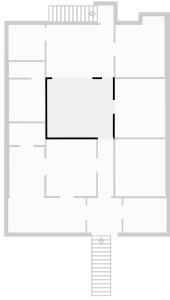

▼ Dining Room
1st Floor

WIDTH: 4.13 m • LENGTH: 3.22 m
AREA: 13.26 m² • PERIMETER: 14.68 m

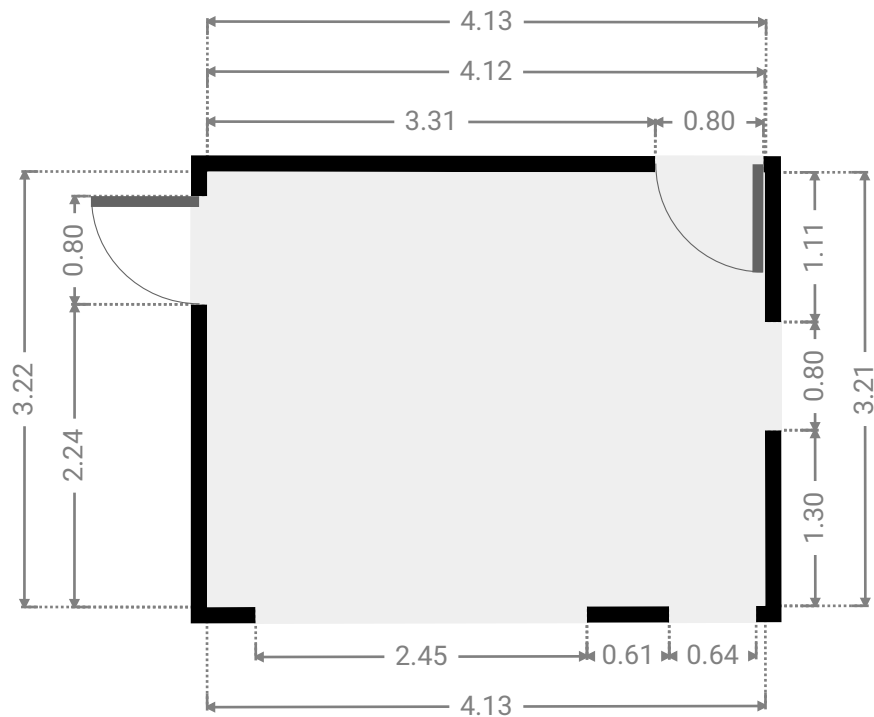
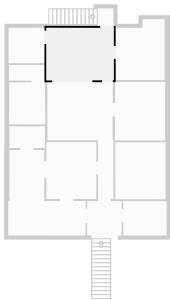

▼ **Bedroom**
1st Floor

WIDTH: 3.08 m • LENGTH: 3.60 m
AREA: 11.07 m² • PERIMETER: 13.35 m

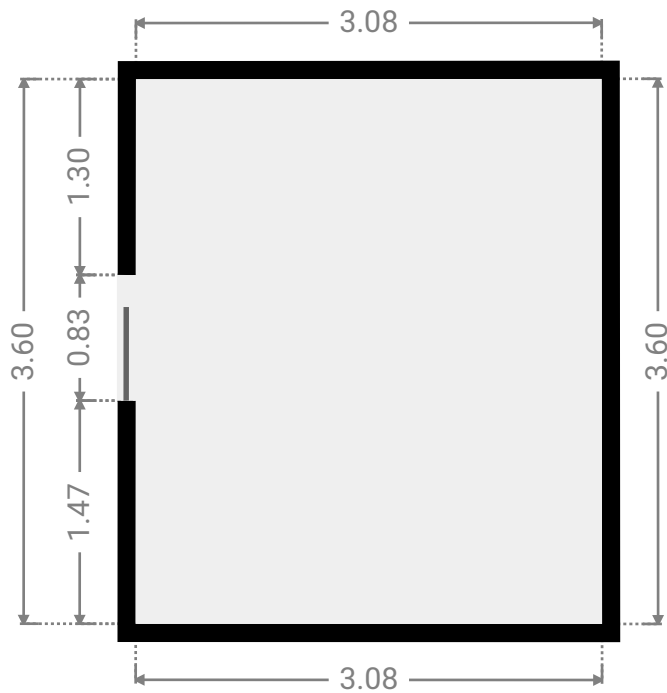
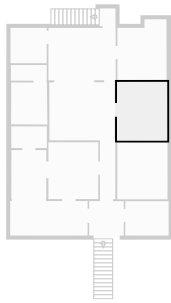

▼ **Kitchen**
1st Floor

WIDTH: 3.02 m • LENGTH: 3.73 m
AREA: 10.36 m² • PERIMETER: 13.49 m

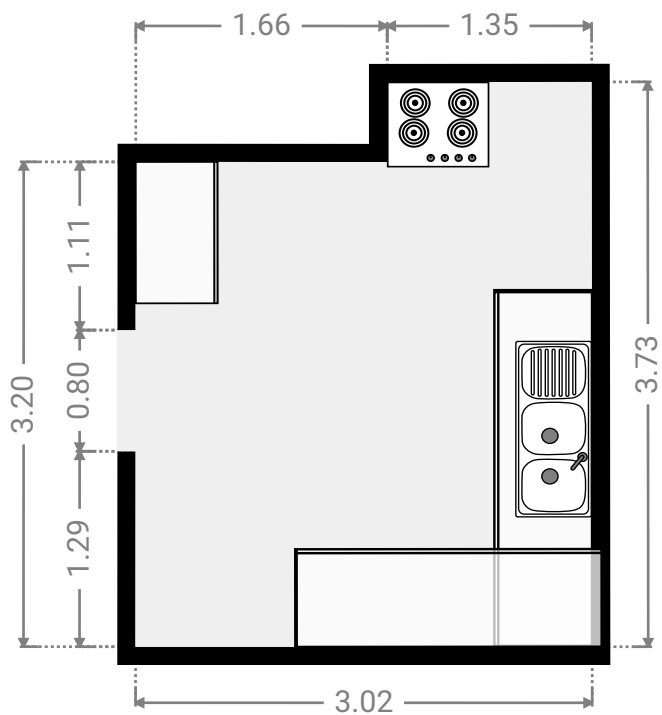
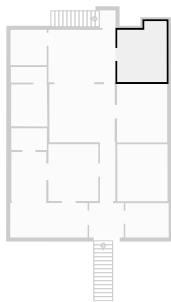

▼ Bathroom
1st Floor

WIDTH: 2.22 m • LENGTH: 2.17 m
AREA: 4.82 m² • PERIMETER: 8.78 m

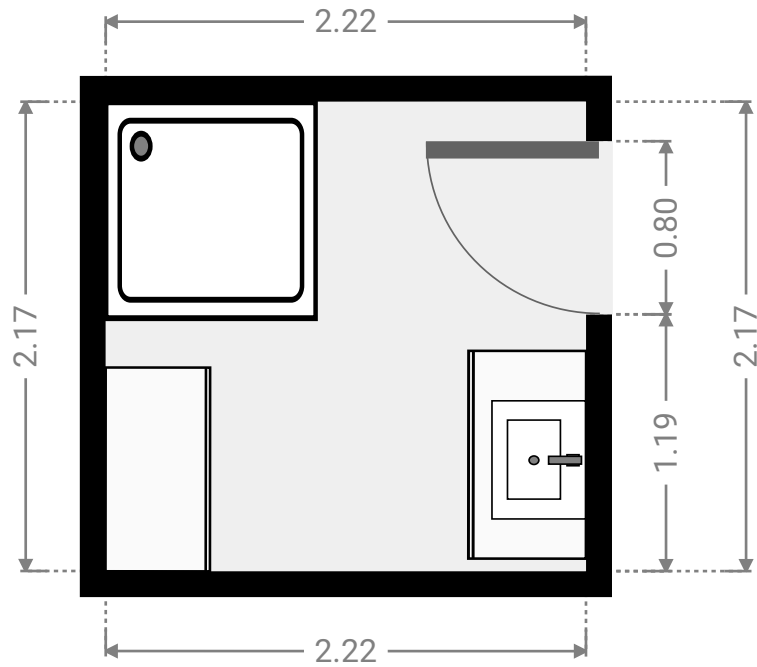
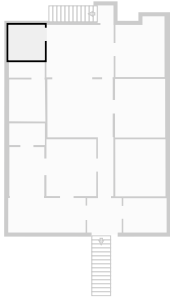

▼ Toilet
1st Floor

WIDTH: 2.20 m • LENGTH: 0.96 m
AREA: 2.11 m² • PERIMETER: 6.32 m

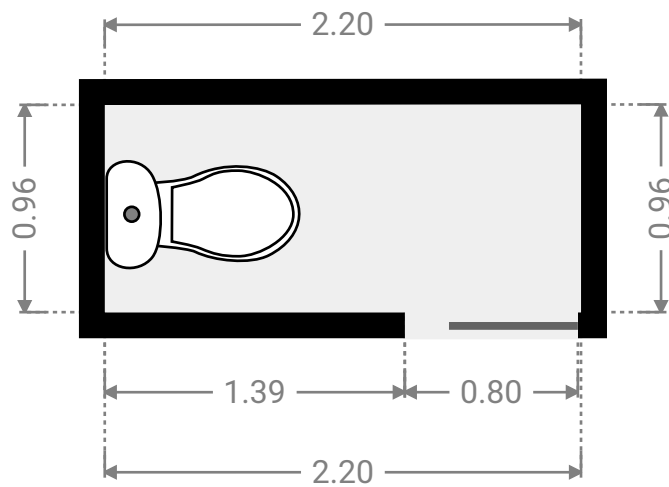
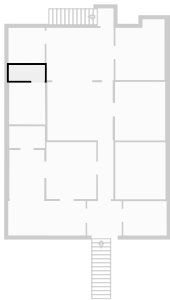

▼ Other
1st Floor

WIDTH: 2.23 m • LENGTH: 2.58 m
AREA: 5.68 m² • PERIMETER: 9.56 m

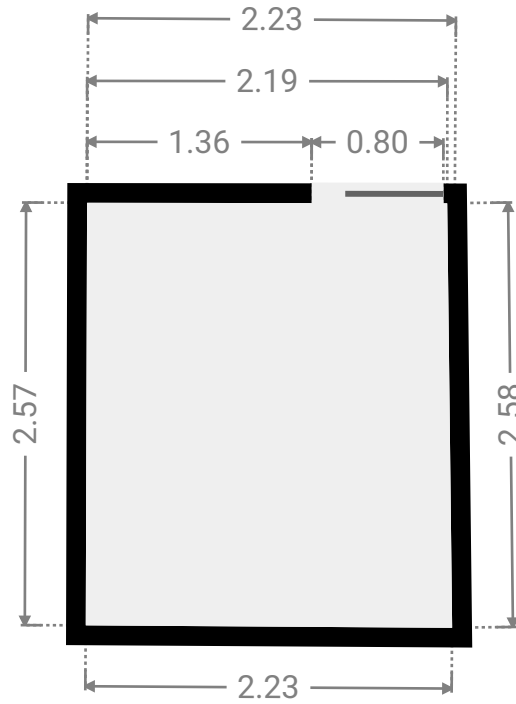
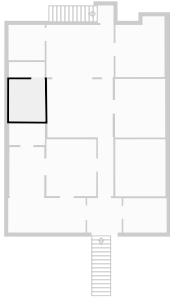

▼ Other
1st Floor

WIDTH: 0.98 m • LENGTH: 1.08 m
AREA: 1.06 m² • PERIMETER: 4.12 m

