

35 Burnett Street

Created on
2021-05-13

Floors
2

▼ Ground Floor



▼ Living Room
Ground Floor

WIDTH: 5.23 m • LENGTH: 9.38 m
AREA: 41.89 m² • PERIMETER: 28.88 m

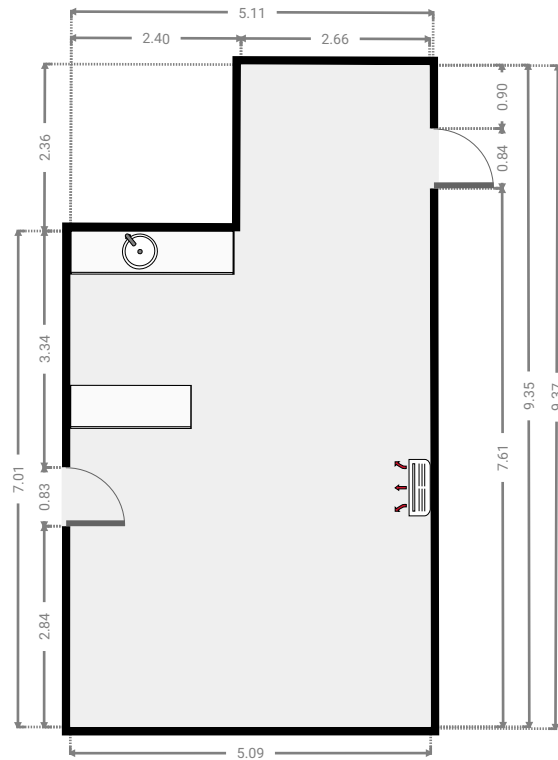
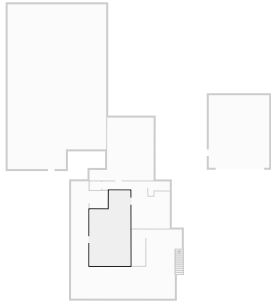

▼ Bedroom
Ground Floor

WIDTH: 4.78 m • LENGTH: 4.70 m
AREA: 21.62 m² • PERIMETER: 20.26 m

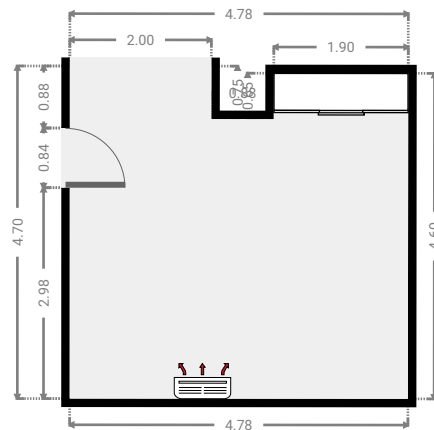
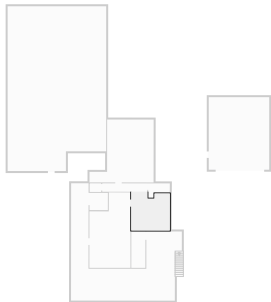

▼ **Hall**
Ground Floor

WIDTH: 5.58 m • LENGTH: 1.04 m
AREA: 5.80 m² • PERIMETER: 13.24 m

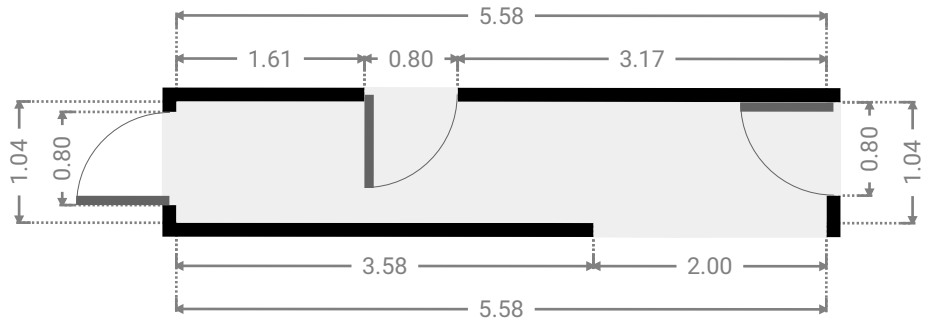
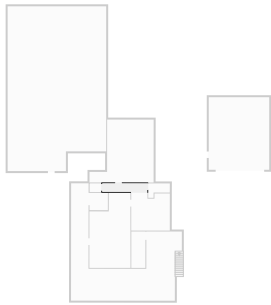

▼ **Bathroom**
Ground Floor

WIDTH: 2.68 m • LENGTH: 1.78 m
AREA: 3.44 m² • PERIMETER: 8.90 m

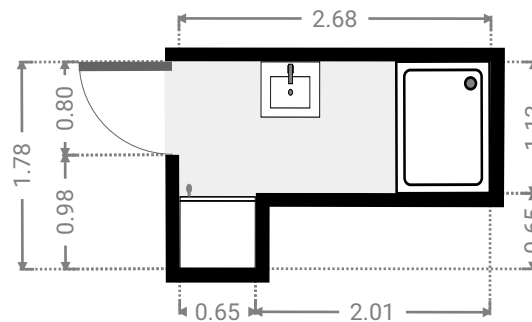
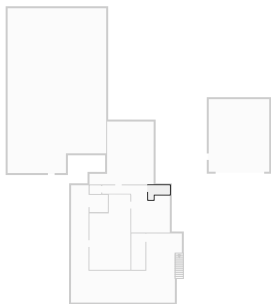

▼ Toilet
Ground Floor

WIDTH: 1.60 m • LENGTH: 1.04 m
AREA: 1.53 m² • PERIMETER: 4.97 m

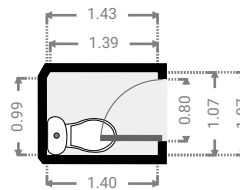
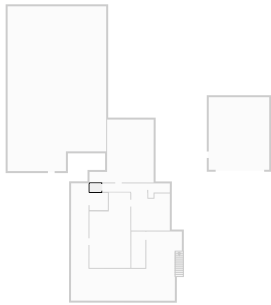

▼ Other
Ground Floor

WIDTH: 7.95 m • LENGTH: 7.80 m
AREA: 47.84 m² • PERIMETER: 31.50 m

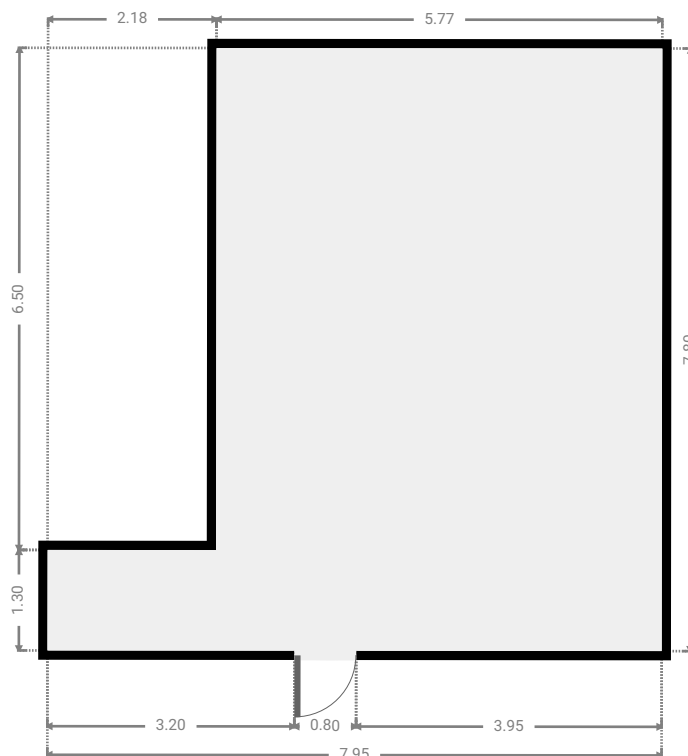
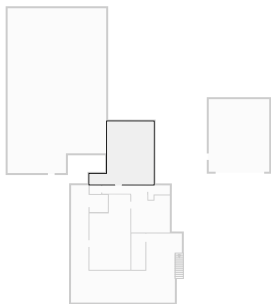

▼ Other
Ground Floor

WIDTH: 1.74 m • LENGTH: 4.54 m
AREA: 7.85 m² • PERIMETER: 12.51 m

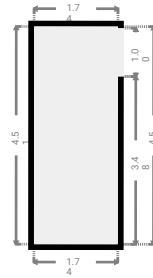
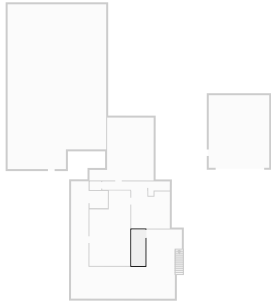

▼ Other
Ground Floor

WIDTH: 13.75 m • LENGTH: 14.56 m
AREA: 92.27 m² • PERIMETER: 65.87 m

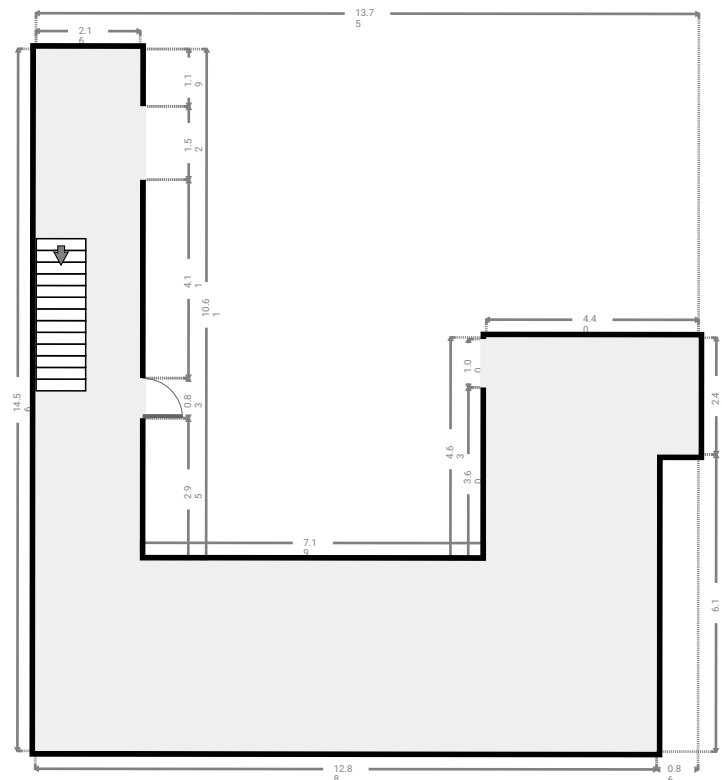
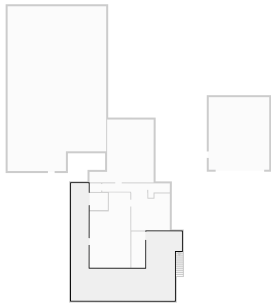

▼ Laundry Room
Ground Floor

WIDTH: 2.27 m • LENGTH: 2.14 m
AREA: 4.87 m² • PERIMETER: 8.83 m

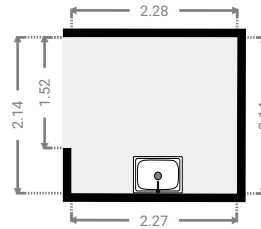
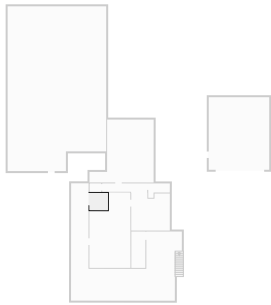

▼ Garage
Ground Floor

WIDTH: 7.50 m • LENGTH: 9.00 m
AREA: 67.50 m² • PERIMETER: 33.00 m

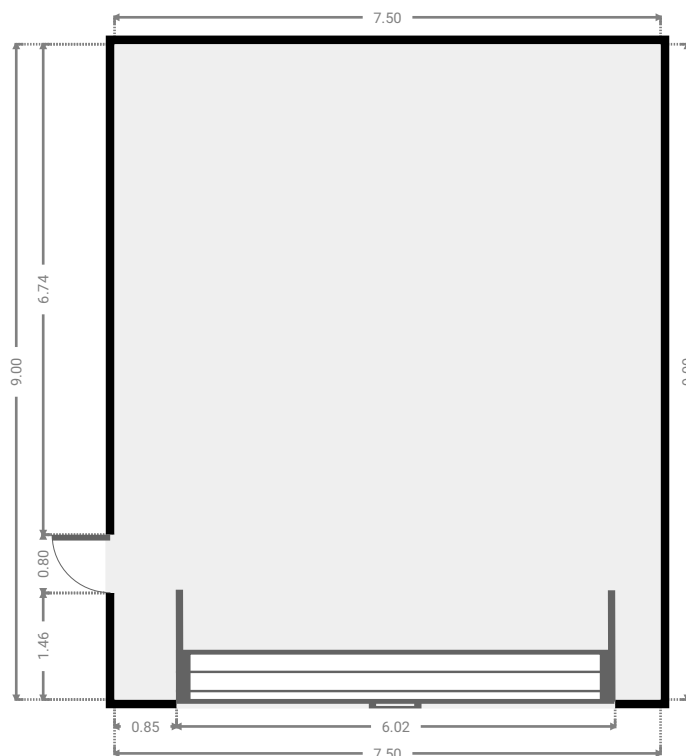
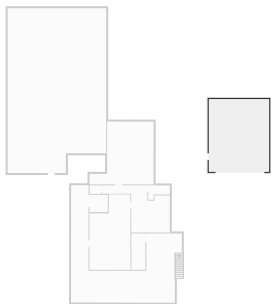

▼ Other
Ground Floor

WIDTH: 12.23 m • LENGTH: 20.45 m
AREA: 237.86 m² • PERIMETER: 65.36 m

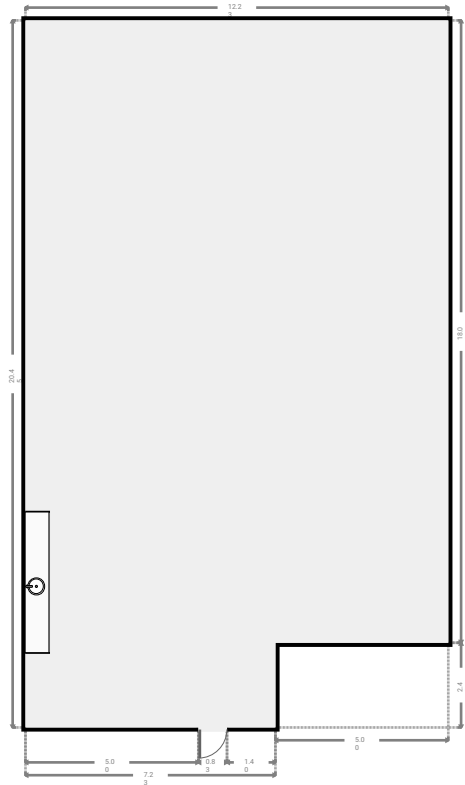
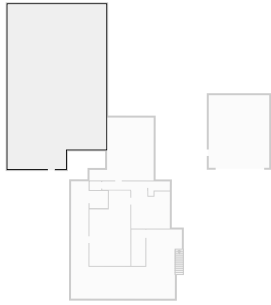

▼ 1st Floor

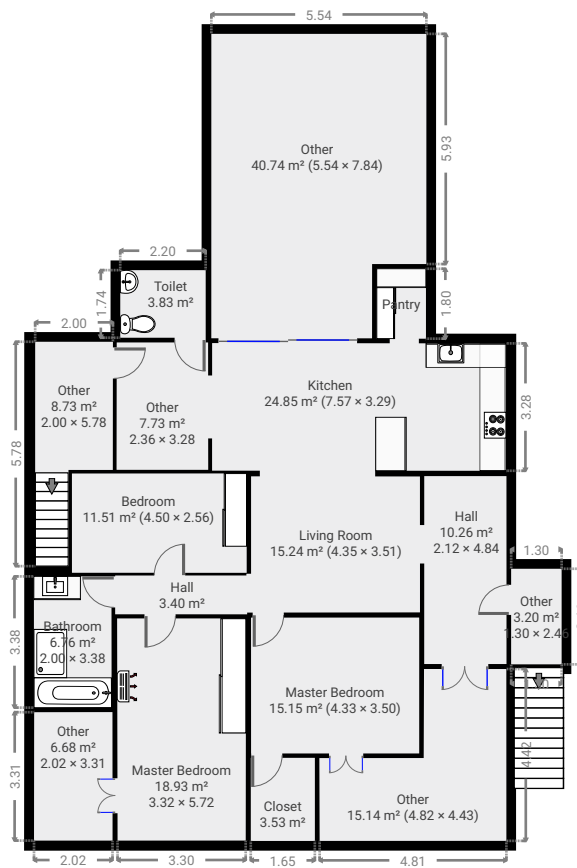

▼ Master Bedroom
1st Floor

WIDTH: 3.32 m • LENGTH: 5.72 m
AREA: 18.93 m² • PERIMETER: 18.06 m

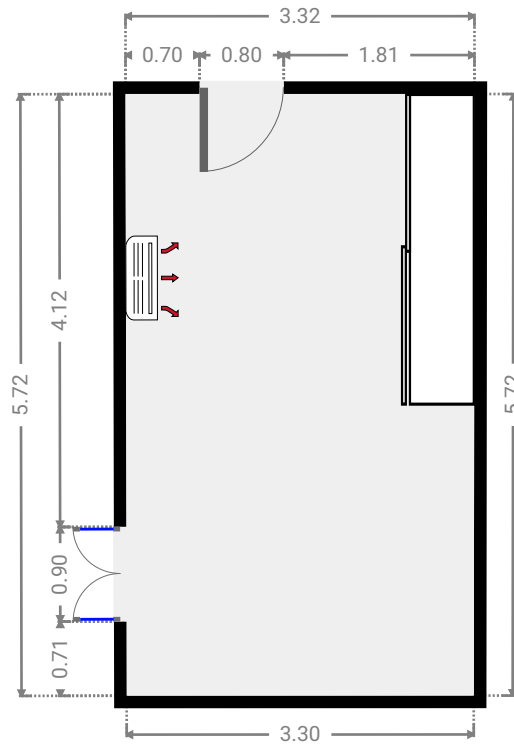
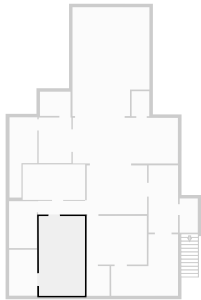

▼ Other
1st Floor

WIDTH: 2.00 m • LENGTH: 5.78 m
AREA: 8.73 m² • PERIMETER: 15.56 m

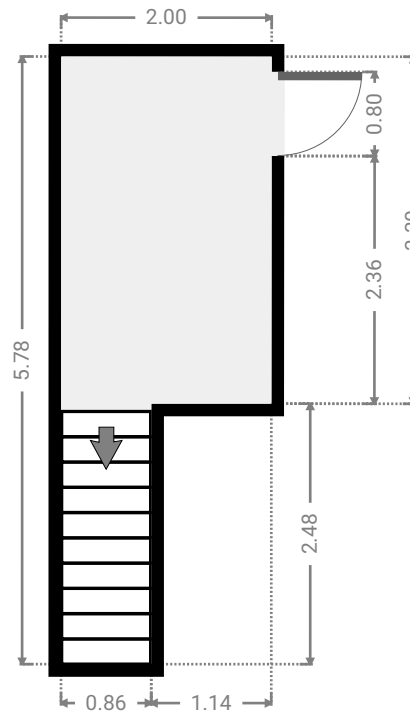
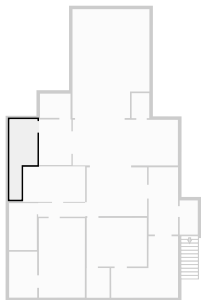

▼ Other
1st Floor

WIDTH: 5.54 m • LENGTH: 7.84 m
AREA: 40.74 m² • PERIMETER: 26.75 m

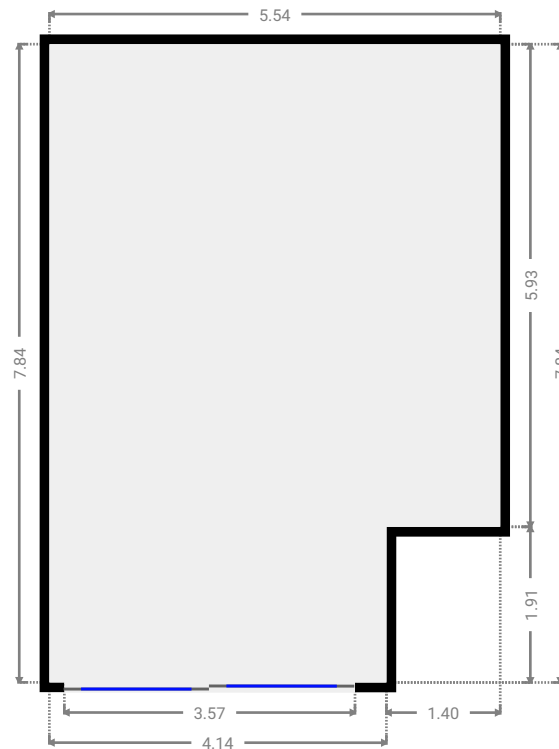
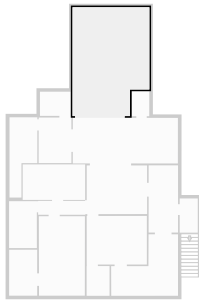

▼ Toilet
1st Floor

WIDTH: 2.20 m • LENGTH: 1.74 m
AREA: 3.83 m² • PERIMETER: 7.88 m

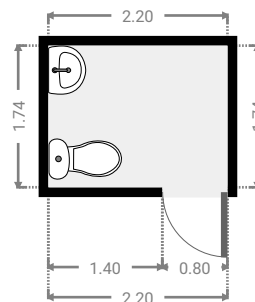
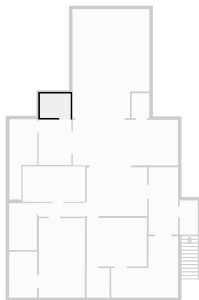

▼ Other
1st Floor

WIDTH: 2.36 m • LENGTH: 3.28 m
AREA: 7.73 m² • PERIMETER: 11.27 m

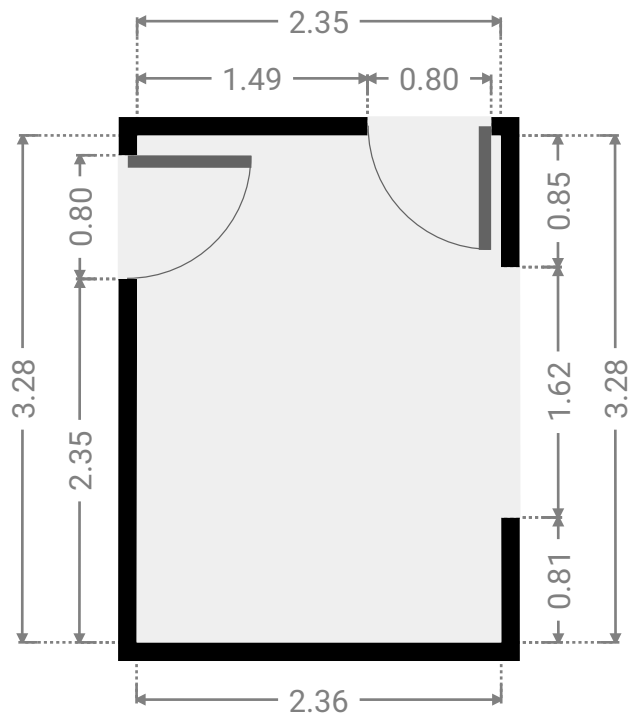
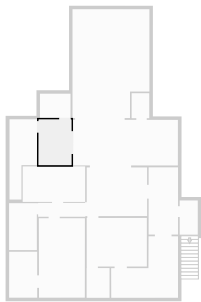

▼ Pantry
1st Floor

WIDTH: 1.27 m • LENGTH: 1.80 m
AREA: 2.29 m² • PERIMETER: 6.14 m

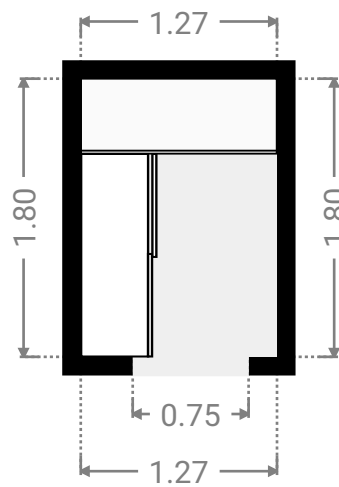
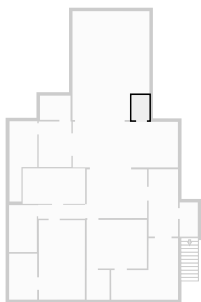

▼ **Kitchen**
1st Floor

WIDTH: 7.57 m • LENGTH: 3.29 m
AREA: 24.85 m² • PERIMETER: 21.71 m

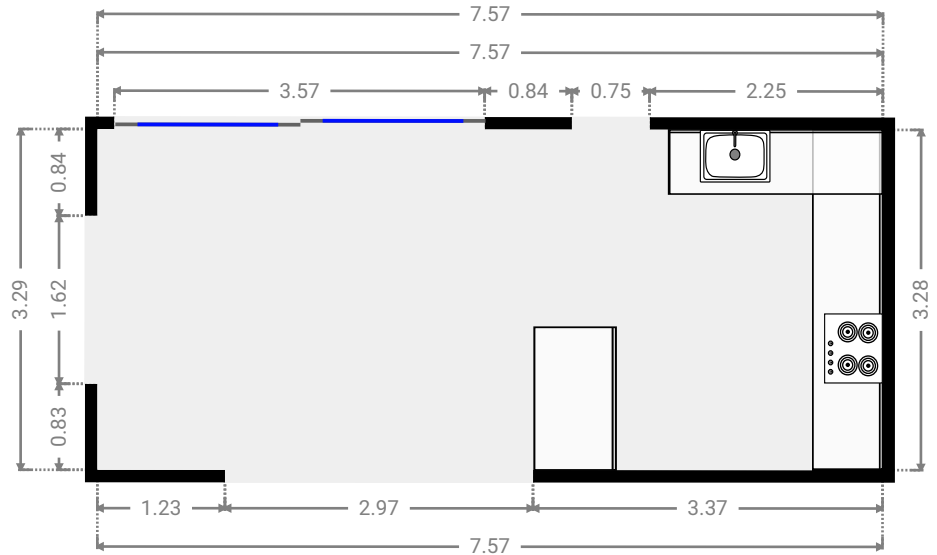
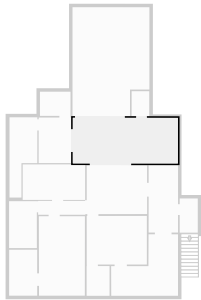

▼ **Other**
1st Floor

WIDTH: 2.02 m • LENGTH: 3.31 m
AREA: 6.68 m² • PERIMETER: 10.65 m

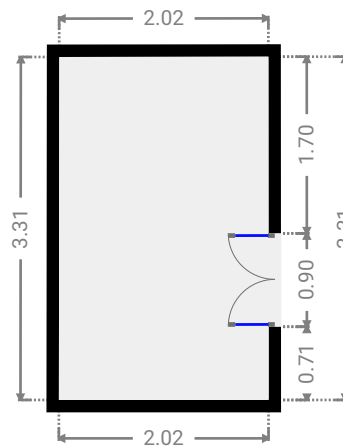

▼ **Bathroom**
1st Floor

WIDTH: 2.00 m • LENGTH: 3.38 m
AREA: 6.76 m² • PERIMETER: 10.76 m

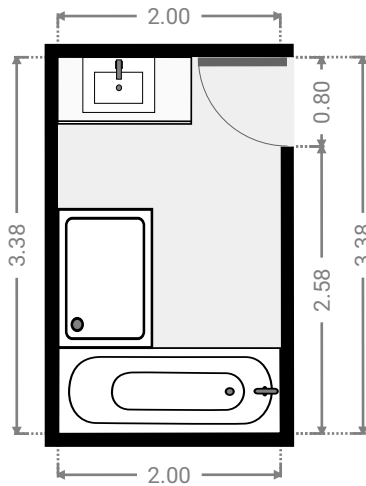
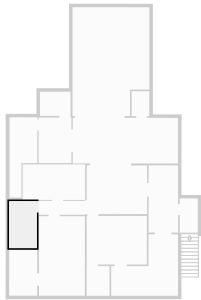

▼ **Hall**
1st Floor

WIDTH: 2.12 m • LENGTH: 4.84 m
AREA: 10.26 m² • PERIMETER: 13.92 m

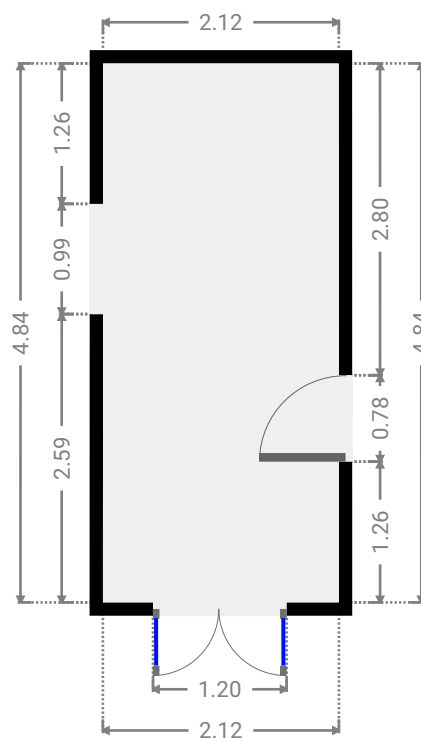
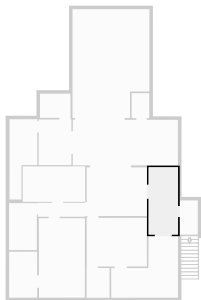

▼ **Bedroom**
1st Floor

WIDTH: 4.50 m • LENGTH: 2.56 m
AREA: 11.51 m² • PERIMETER: 14.12 m

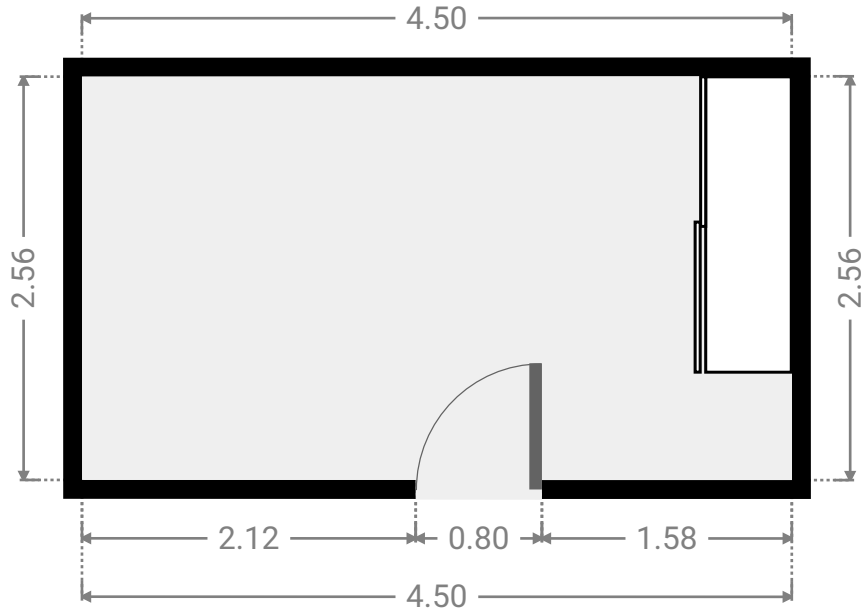
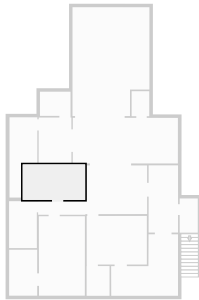

▼ **Hall**
1st Floor

WIDTH: 3.40 m • LENGTH: 1.00 m
AREA: 3.40 m² • PERIMETER: 8.80 m

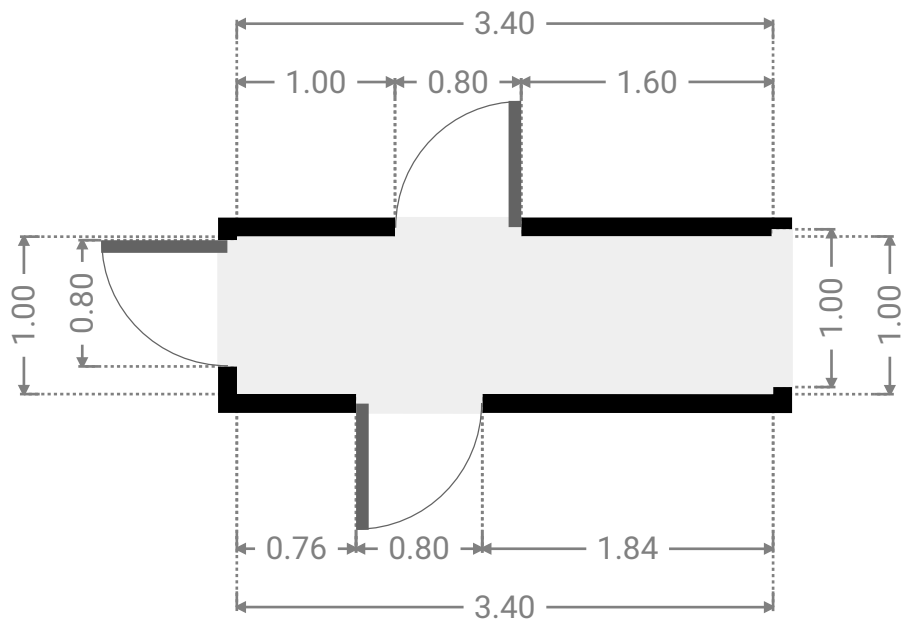
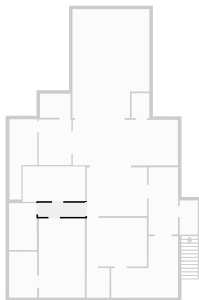

▼ Other
1st Floor

WIDTH: 4.82 m • LENGTH: 4.43 m
AREA: 15.14 m² • PERIMETER: 18.47 m

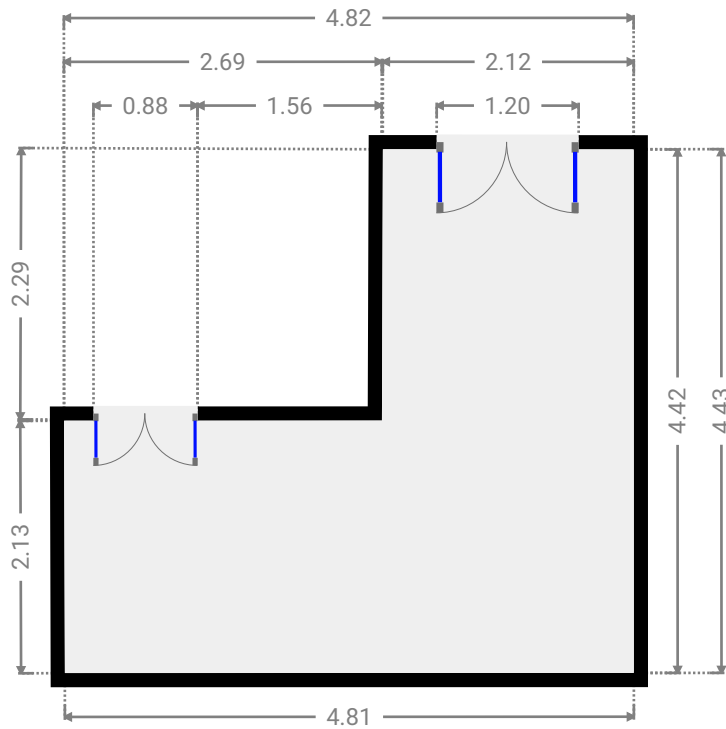
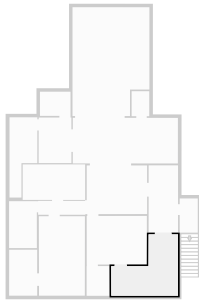

▼ Closet
1st Floor

WIDTH: 1.65 m • LENGTH: 2.14 m
AREA: 3.53 m² • PERIMETER: 7.58 m

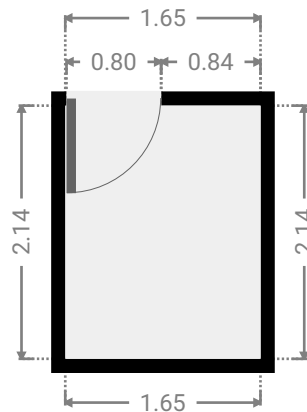

▼ **Master Bedroom**
1st Floor

WIDTH: 4.33 m • LENGTH: 3.50 m
AREA: 15.15 m² • PERIMETER: 15.66 m

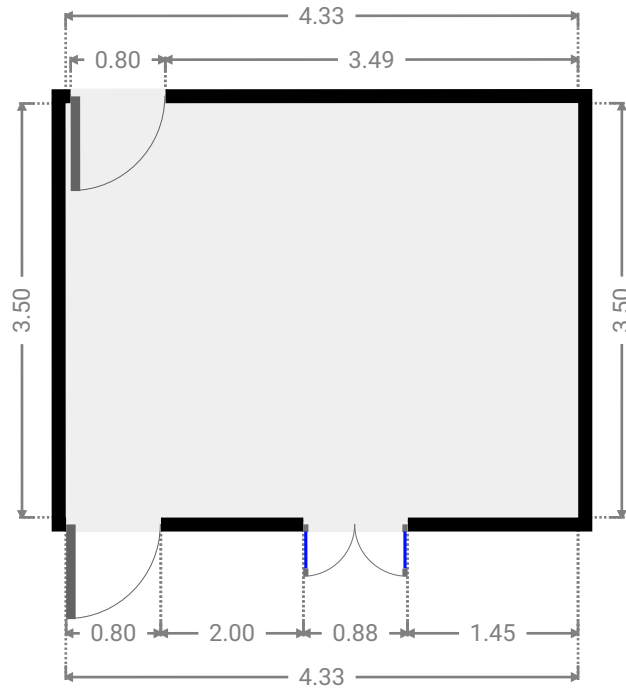
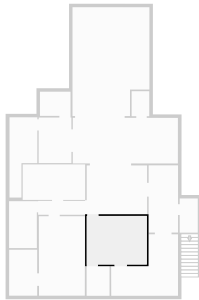

▼ **Living Room**
1st Floor

WIDTH: 4.35 m • LENGTH: 3.51 m
AREA: 15.24 m² • PERIMETER: 15.71 m

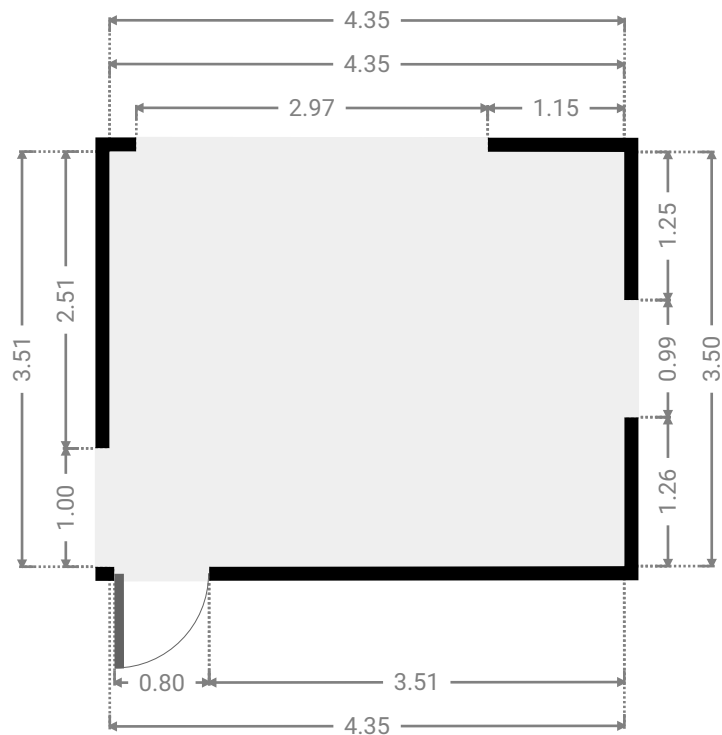
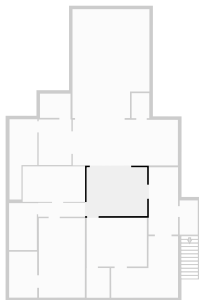

▼ Other
1st Floor

WIDTH: 1.30 m • LENGTH: 2.46 m
AREA: 3.20 m² • PERIMETER: 7.52 m

