

349 Waterloo Street

SUBMITTED BY

Ray White Rockhampton Casey
stockers@cqoz.com

CREATED ON

2021-11-25

Floors

1

▼ Ground Floor

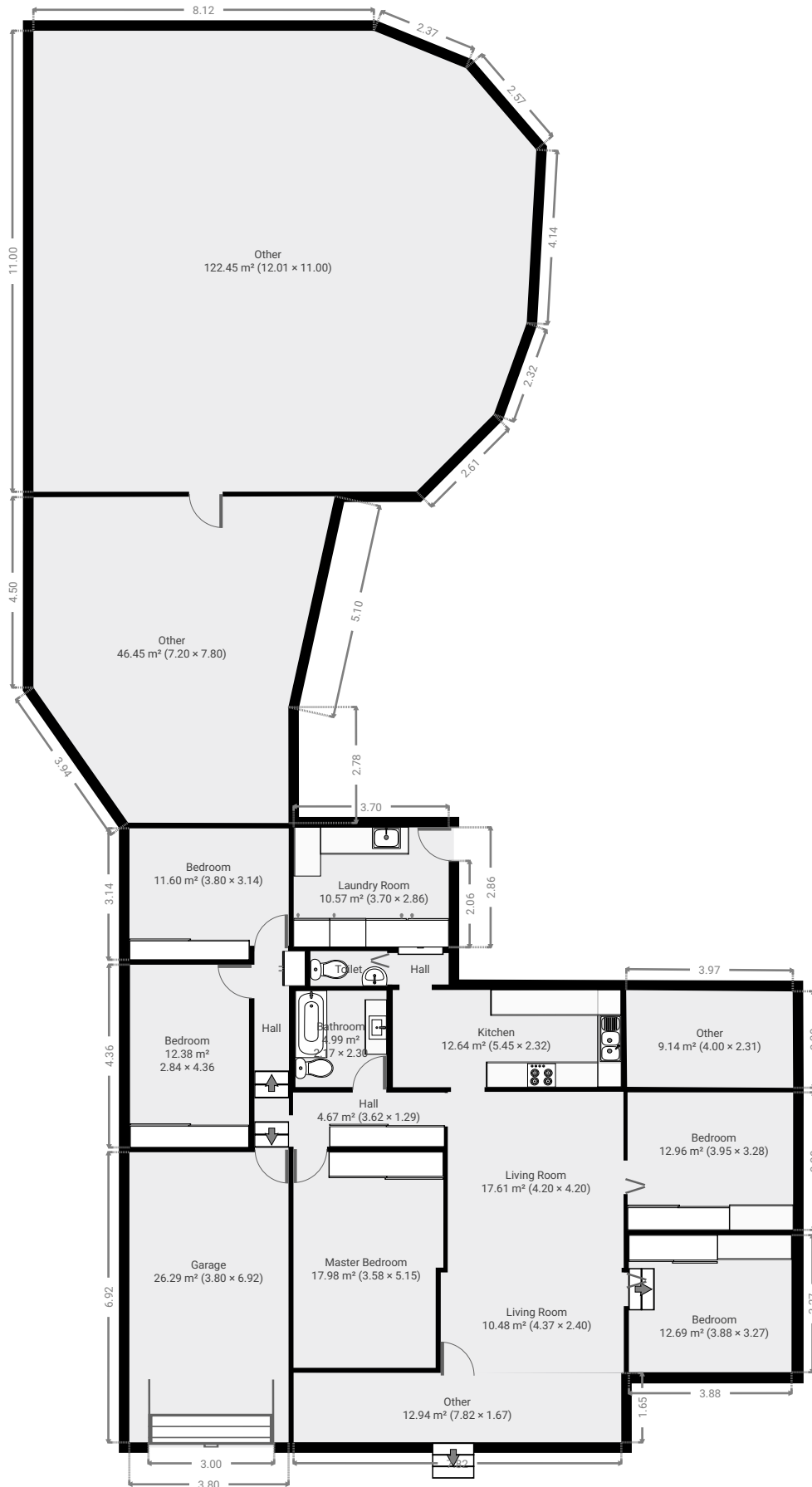

FLOORS: 1

▼ **Bedroom**
Ground Floor

WIDTH: 2.84 m • LENGTH: 4.36 m
AREA: 12.38 m² • PERIMETER: 14.40 m

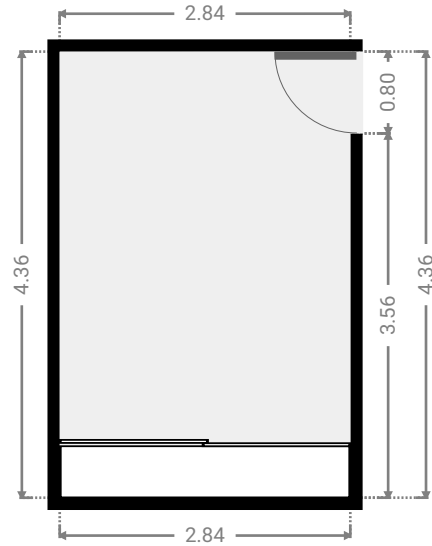
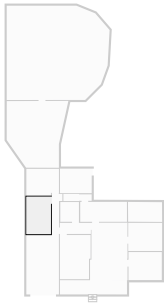

▼ **Other**
Ground Floor

WIDTH: 7.82 m • LENGTH: 1.67 m
AREA: 12.94 m² • PERIMETER: 18.95 m

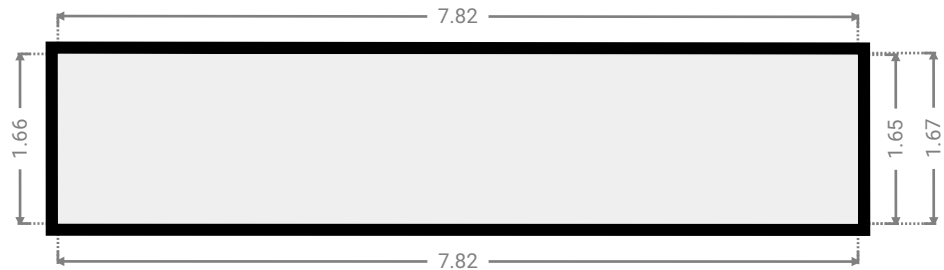
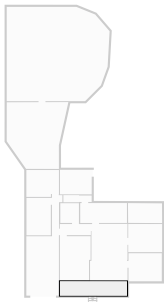

FLOORS: 1

▼ Other
Ground Floor

WIDTH: 12.01 m • LENGTH: 11.00 m
AREA: 122.45 m² • PERIMETER: 42.27 m

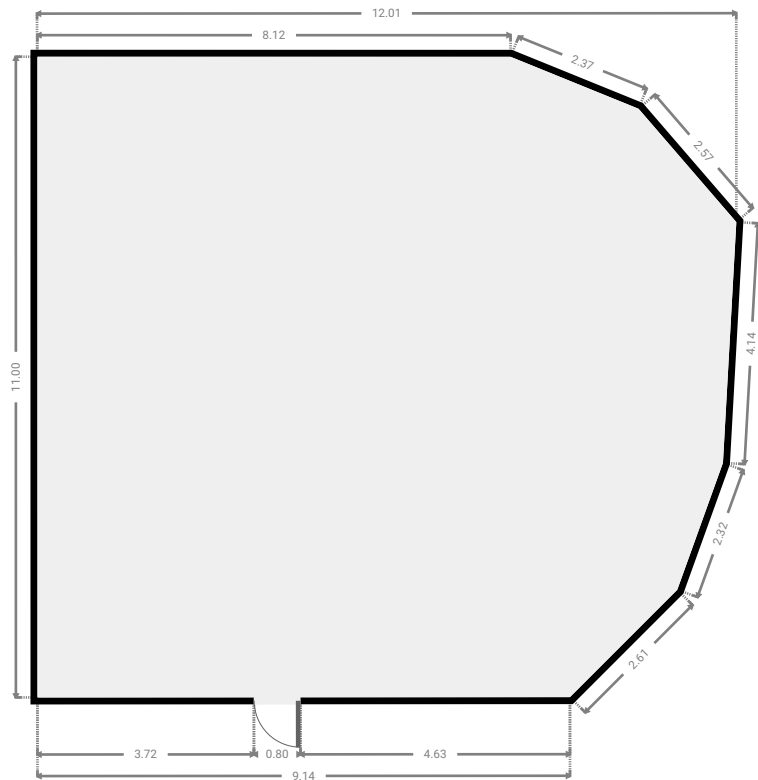
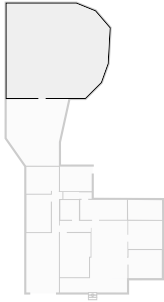

▼ Other
Ground Floor

WIDTH: 7.20 m • LENGTH: 7.80 m
AREA: 46.45 m² • PERIMETER: 27.41 m

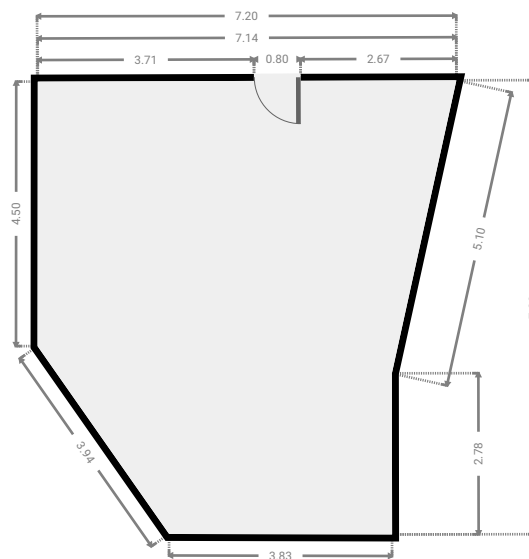
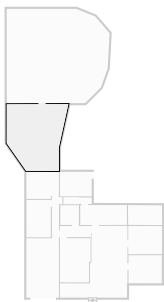

FLOORS: 1

▼ Other
Ground Floor

WIDTH: 4.00 m • LENGTH: 2.31 m
AREA: 9.14 m² • PERIMETER: 12.54 m

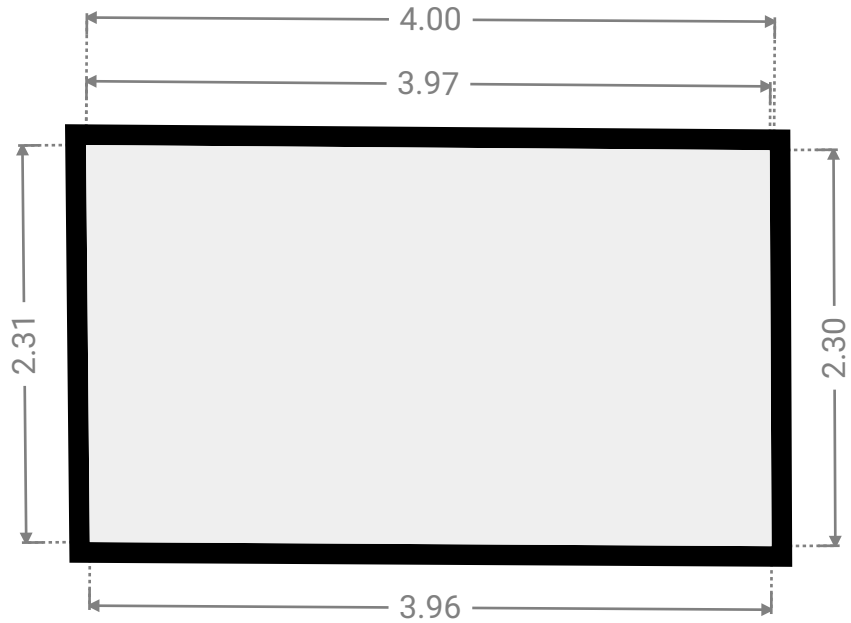
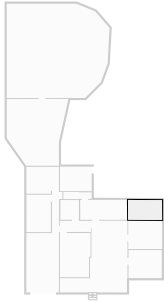

▼ Laundry Room
Ground Floor

WIDTH: 3.70 m • LENGTH: 2.86 m
AREA: 10.57 m² • PERIMETER: 13.12 m

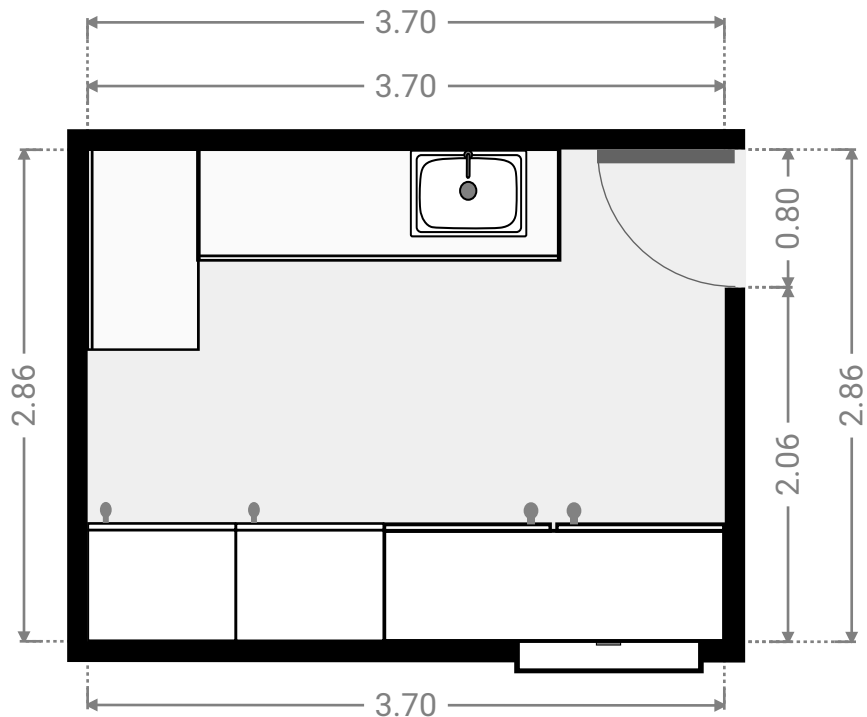
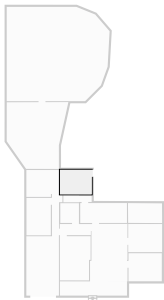

FLOORS: 1

▼ **Toilet**
Ground Floor

WIDTH: 1.83 m • LENGTH: 0.83 m
AREA: 1.52 m² • PERIMETER: 5.32 m

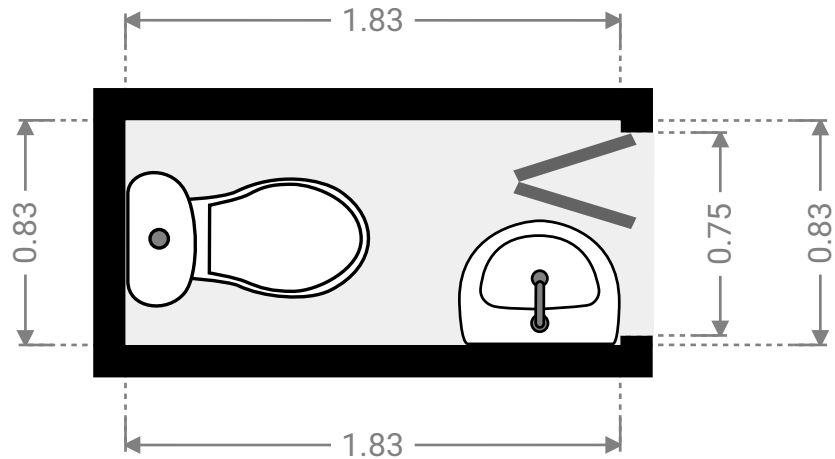
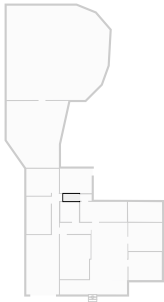

▼ **Hall**
Ground Floor

WIDTH: 1.35 m • LENGTH: 0.75 m
AREA: 1.01 m² • PERIMETER: 4.20 m

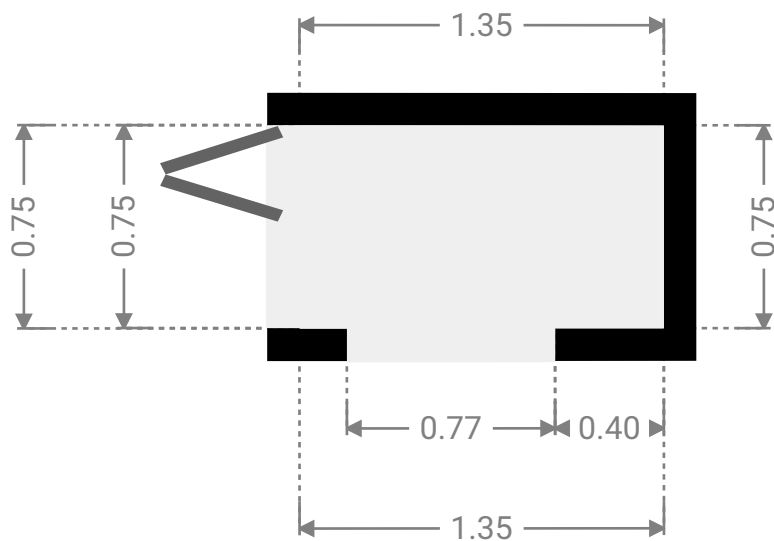
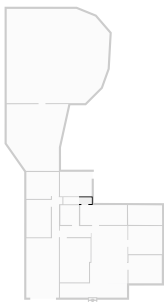

▼ **Kitchen**
Ground Floor

WIDTH: 5.45 m • LENGTH: 2.32 m
AREA: 12.64 m² • PERIMETER: 15.54 m

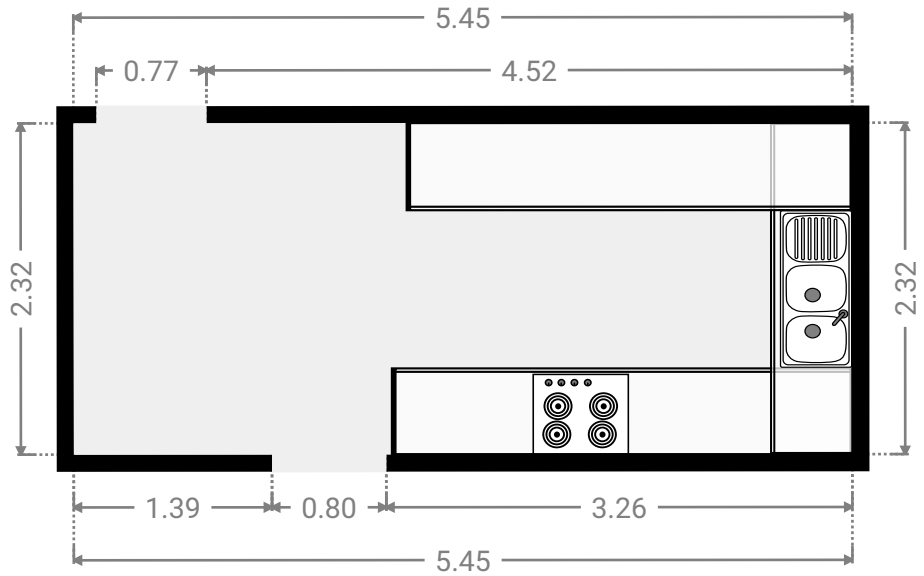
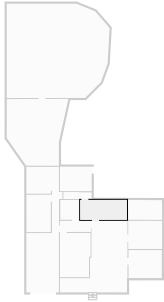

▼ **Bedroom**
Ground Floor

WIDTH: 3.80 m • LENGTH: 3.14 m
AREA: 11.60 m² • PERIMETER: 13.87 m

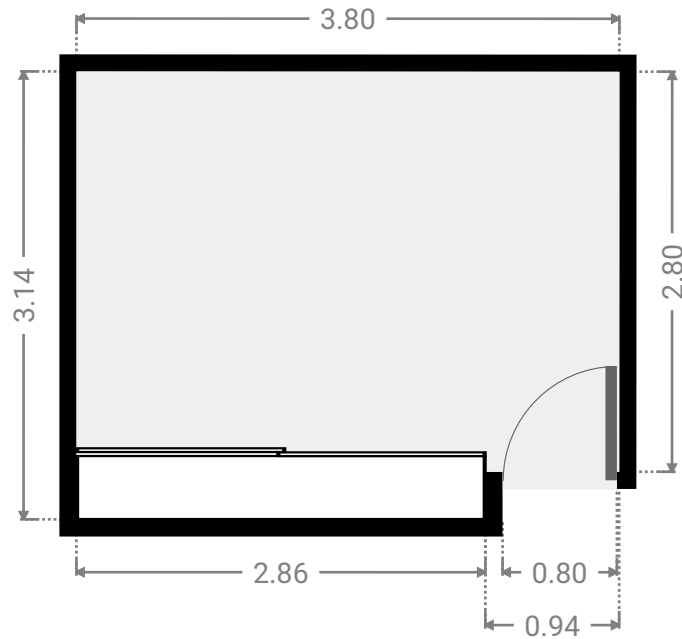
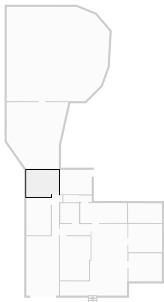

FLOORS: 1

▼ **Living Room**
Ground Floor

WIDTH: 4.37 m • LENGTH: 2.40 m
AREA: 10.48 m² • PERIMETER: 13.54 m

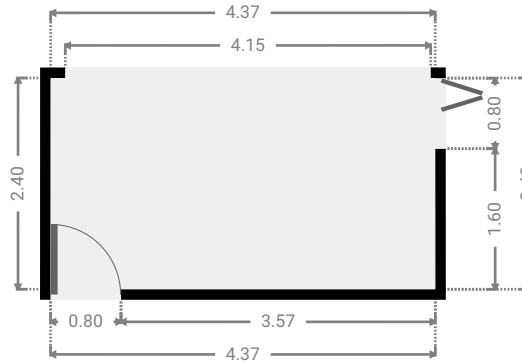
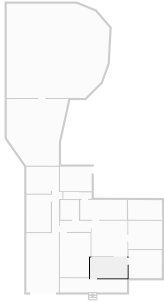

▼ **Garage**
Ground Floor

WIDTH: 3.80 m • LENGTH: 6.92 m
AREA: 26.29 m² • PERIMETER: 21.44 m

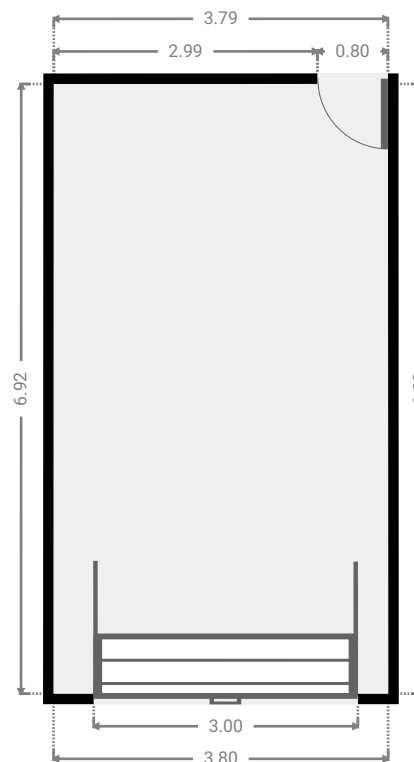
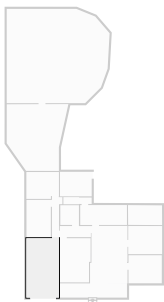

FLOORS: 1

▼ **Hall**
Ground Floor

WIDTH: 1.22 m • LENGTH: 4.67 m
AREA: 4.16 m² • PERIMETER: 11.77 m

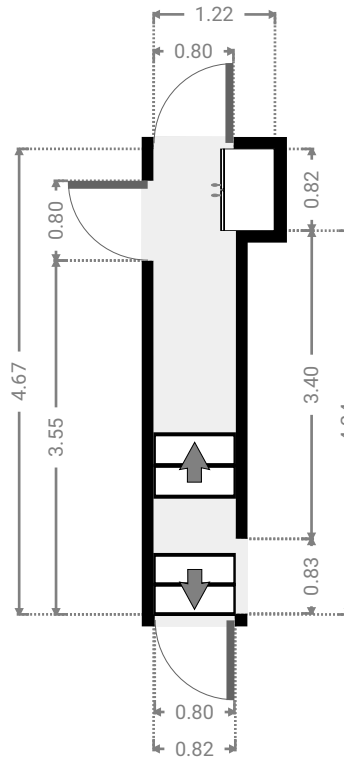
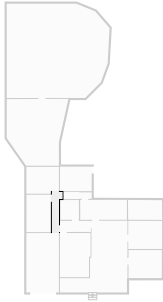

▼ **Master Bedroom**
Ground Floor

WIDTH: 3.58 m • LENGTH: 5.15 m
AREA: 17.98 m² • PERIMETER: 17.45 m

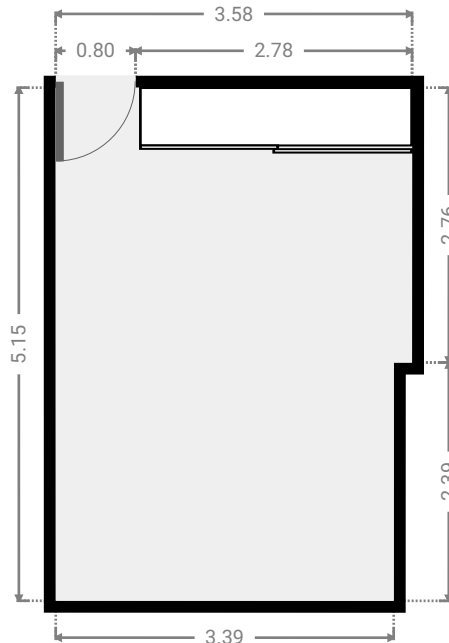
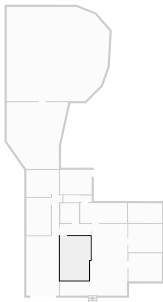

FLOORS: 1

▼ **Bathroom**
Ground Floor

WIDTH: 2.17 m • LENGTH: 2.30 m
AREA: 4.99 m² • PERIMETER: 8.94 m

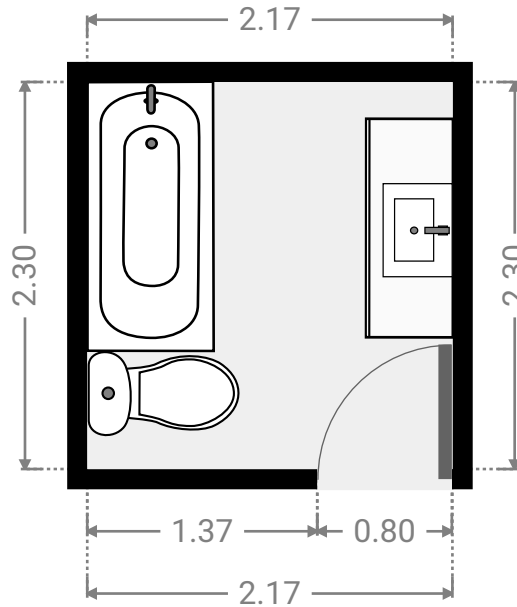
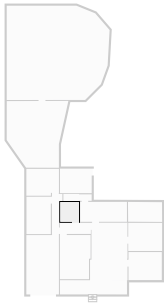

▼ **Hall**
Ground Floor

WIDTH: 3.62 m • LENGTH: 1.29 m
AREA: 4.67 m² • PERIMETER: 9.82 m

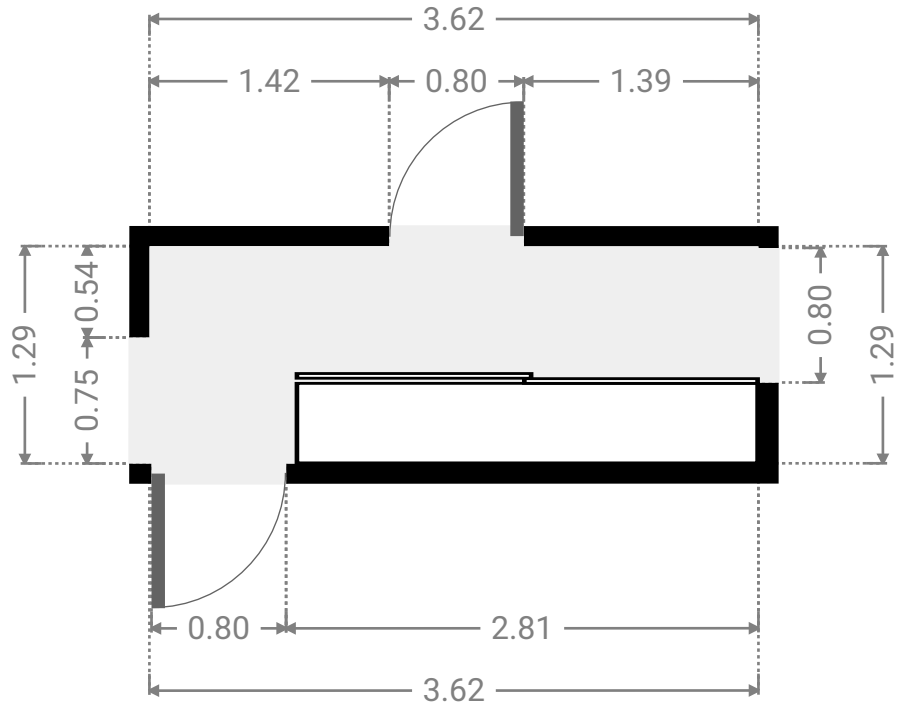
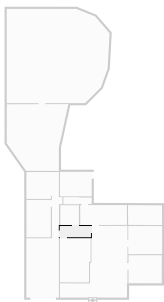

▼ **Bedroom**
Ground Floor

WIDTH: 3.95 m • LENGTH: 3.28 m
AREA: 12.96 m² • PERIMETER: 14.46 m

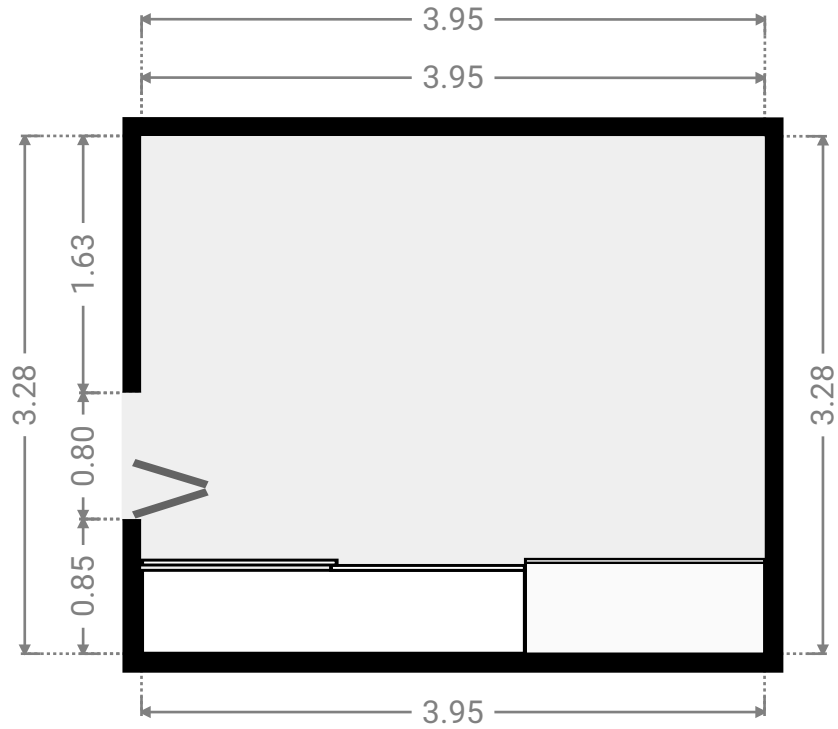
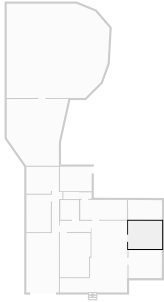

▼ **Bedroom**
Ground Floor

WIDTH: 3.88 m • LENGTH: 3.27 m
AREA: 12.69 m² • PERIMETER: 14.30 m

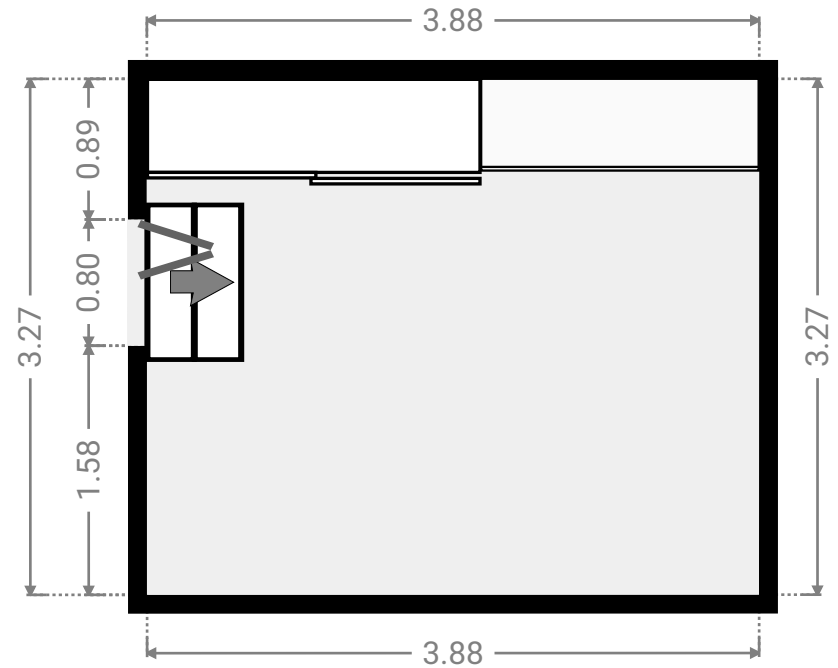
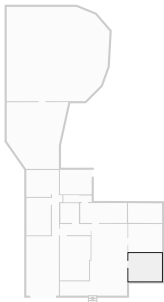

▼ **Living Room**
Ground Floor

WIDTH: 4.20 m • LENGTH: 4.20 m
AREA: 17.61 m² • PERIMETER: 16.79 m

