

345 Lawrence Avenue

SUBMITTED BY

Ray White Rockhampton Casey
stockers@cqoz.com

CREATED ON

2022-04-19

Floors

2

▼ Ground Floor

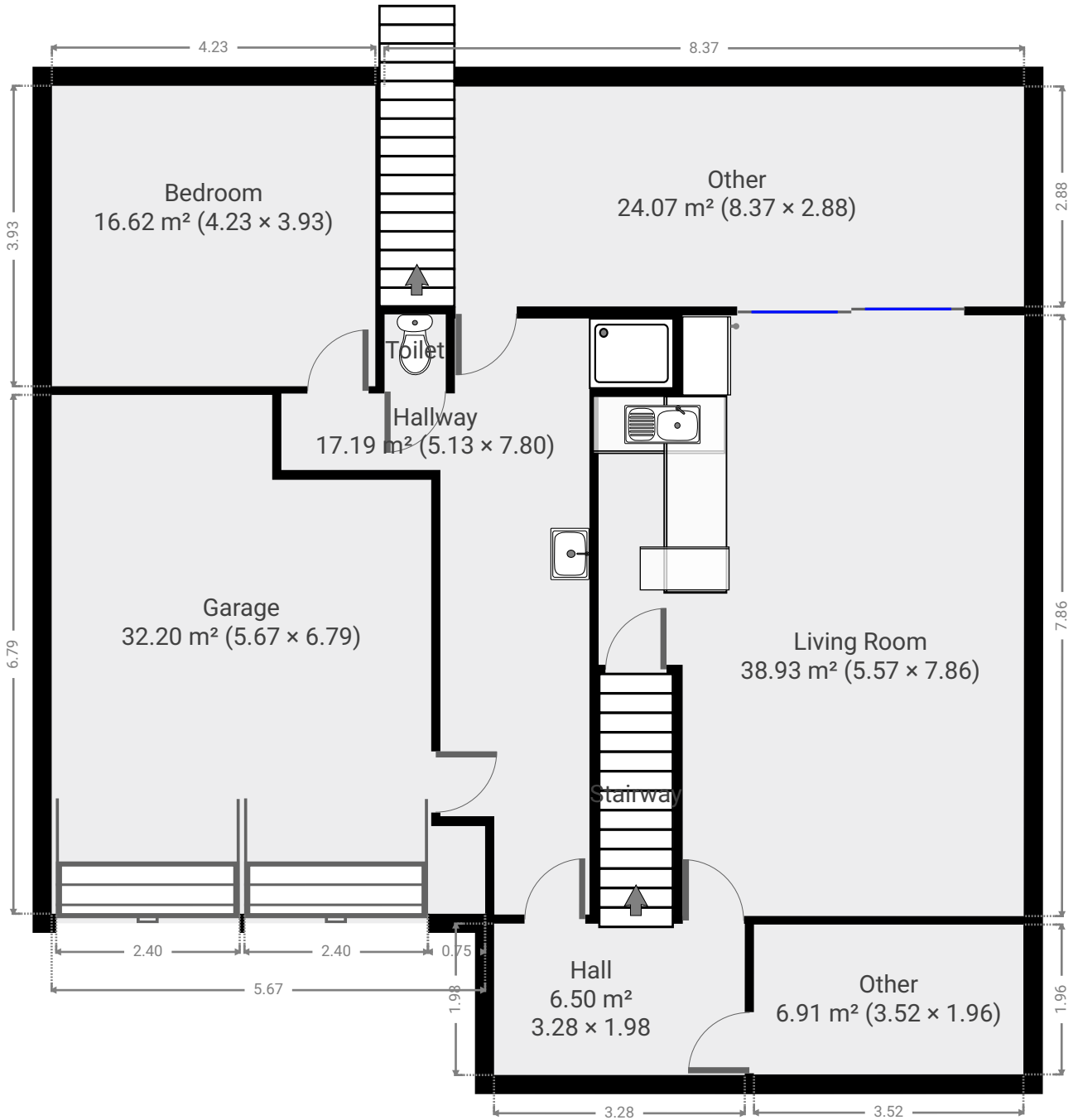

▼ **Hall**
Ground Floor

WIDTH: 3.28 m • LENGTH: 1.98 m
AREA: 6.50 m² • PERIMETER: 10.52 m

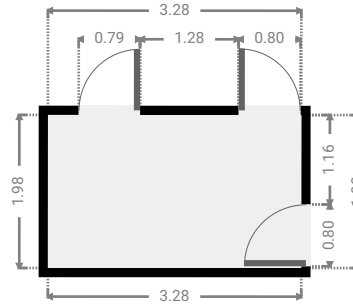
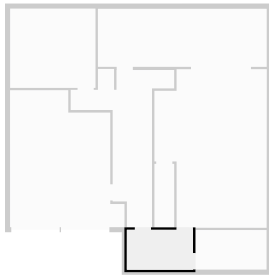

▼ **Living Room**
Ground Floor

WIDTH: 5.57 m • LENGTH: 7.86 m
AREA: 38.93 m² • PERIMETER: 26.85 m

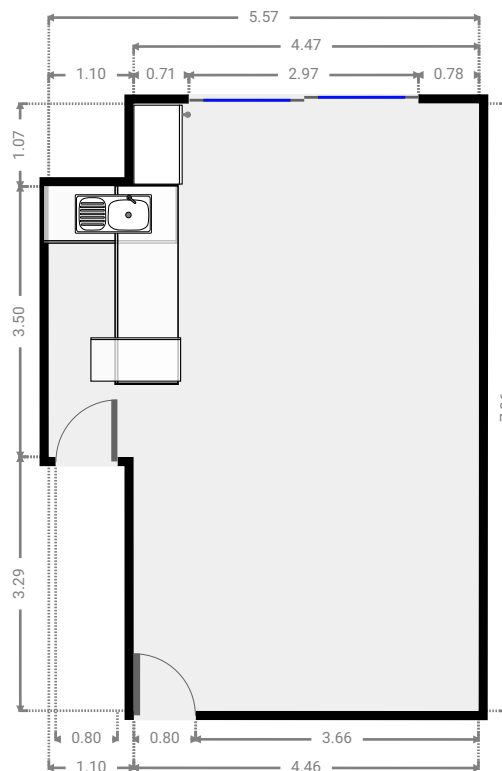
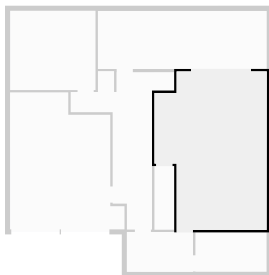

▼ **Stairway**
Ground Floor

WIDTH: 0.98 m • LENGTH: 3.17 m
AREA: 3.10 m² • PERIMETER: 8.27 m

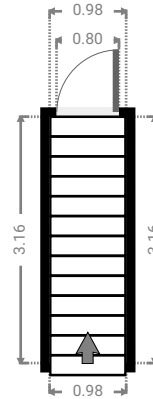
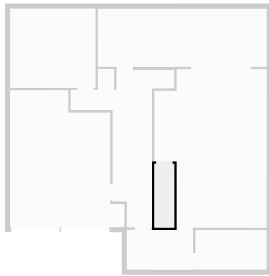

▼ **Hallway**
Ground Floor

WIDTH: 5.07 m • LENGTH: 7.87 m
AREA: 17.19 m² • PERIMETER: 25.85 m

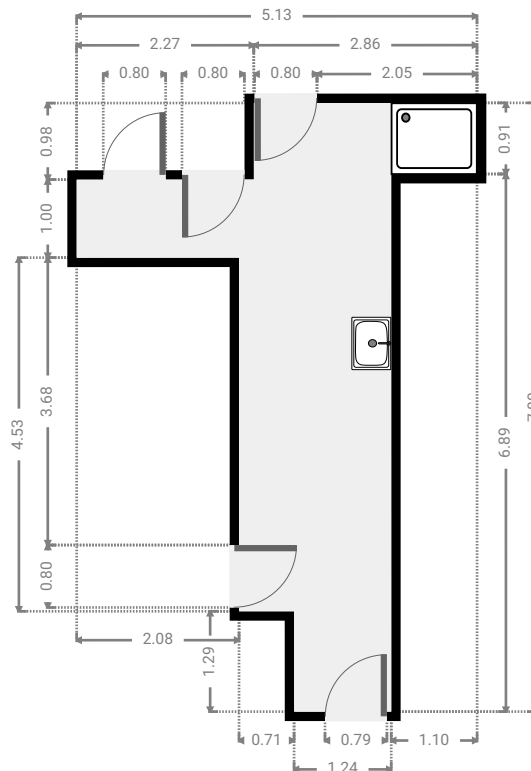
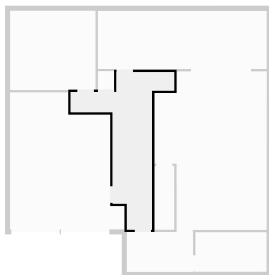

▼ **Toilet**
Ground Floor

WIDTH: 0.80 m • LENGTH: 0.95 m
AREA: 0.76 m² • PERIMETER: 3.50 m

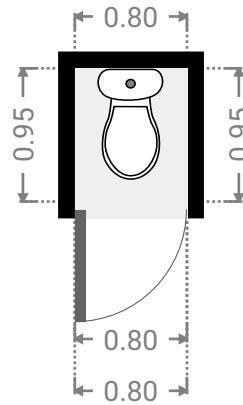
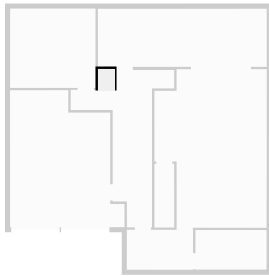

▼ **Bedroom**
Ground Floor

WIDTH: 4.23 m • LENGTH: 3.93 m
AREA: 16.62 m² • PERIMETER: 16.32 m

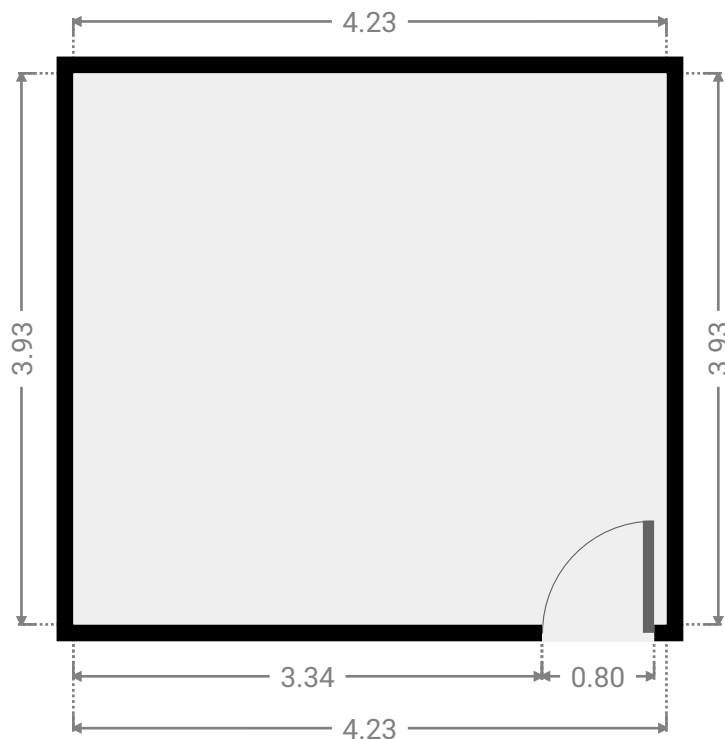
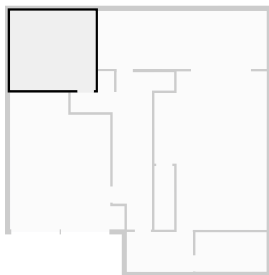

▼ **Garage**
Ground Floor

WIDTH: 5.67 m • LENGTH: 6.76 m
AREA: 32.20 m² • PERIMETER: 24.92 m

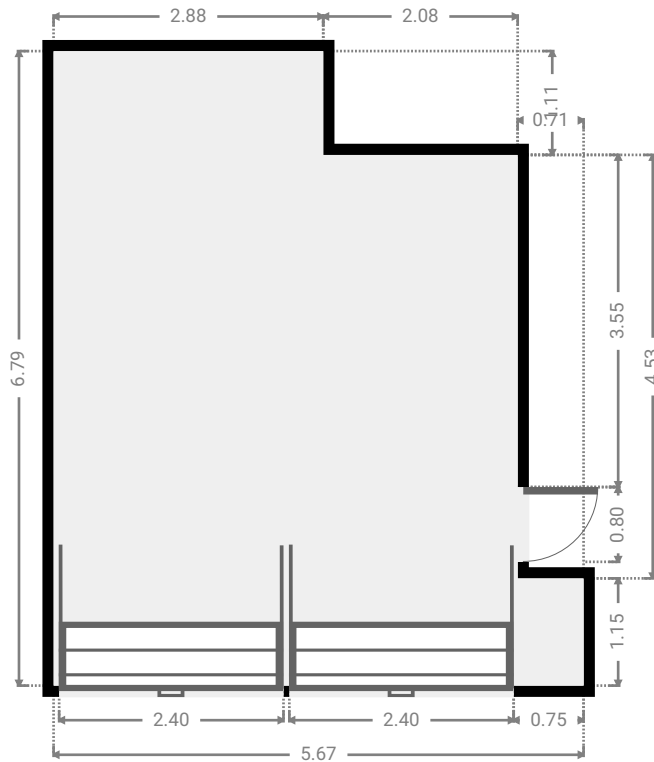
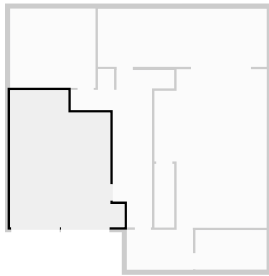

▼ **Other**
Ground Floor

WIDTH: 8.37 m • LENGTH: 2.88 m
AREA: 24.07 m² • PERIMETER: 22.49 m

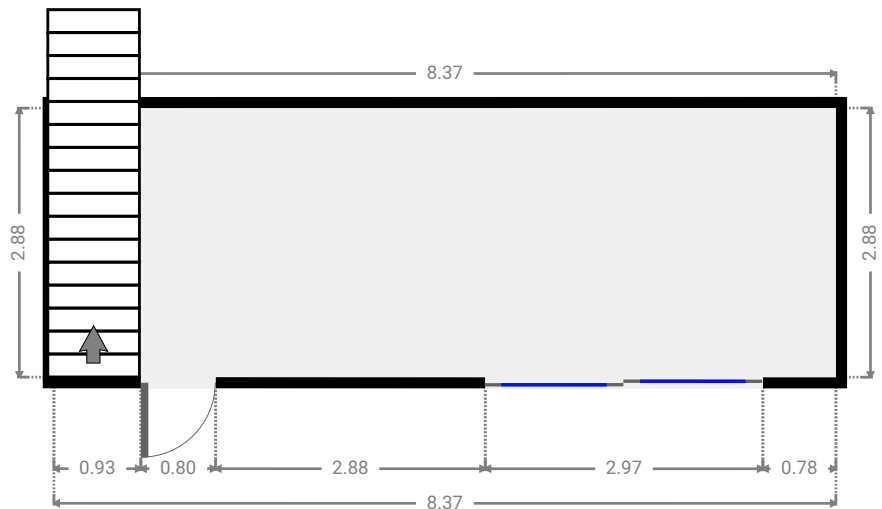
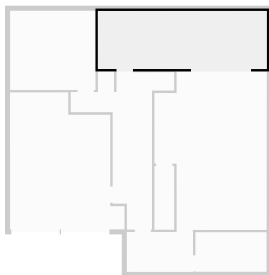

▼ Other
Ground Floor

WIDTH: 3.52 m • LENGTH: 1.96 m
AREA: 6.91 m² • PERIMETER: 10.97 m

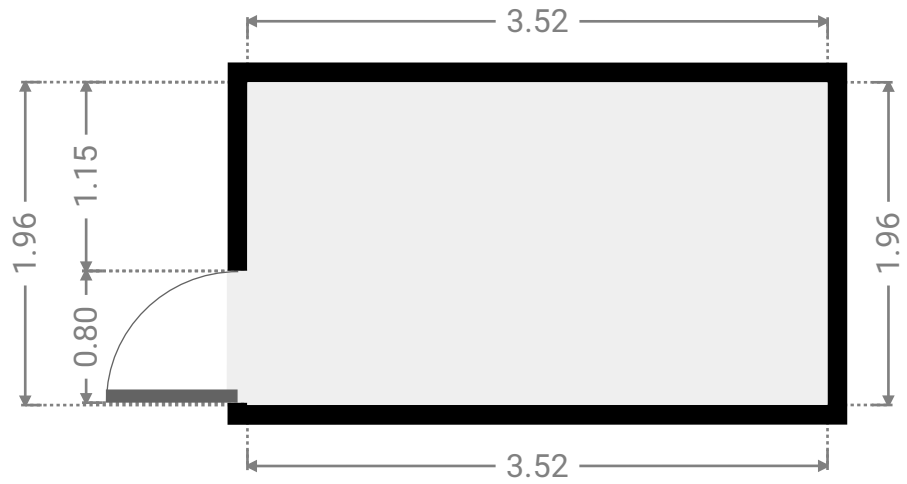
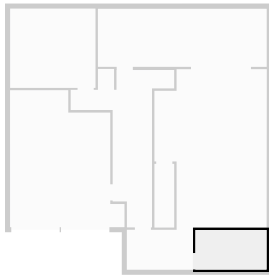

▼ 1st Floor

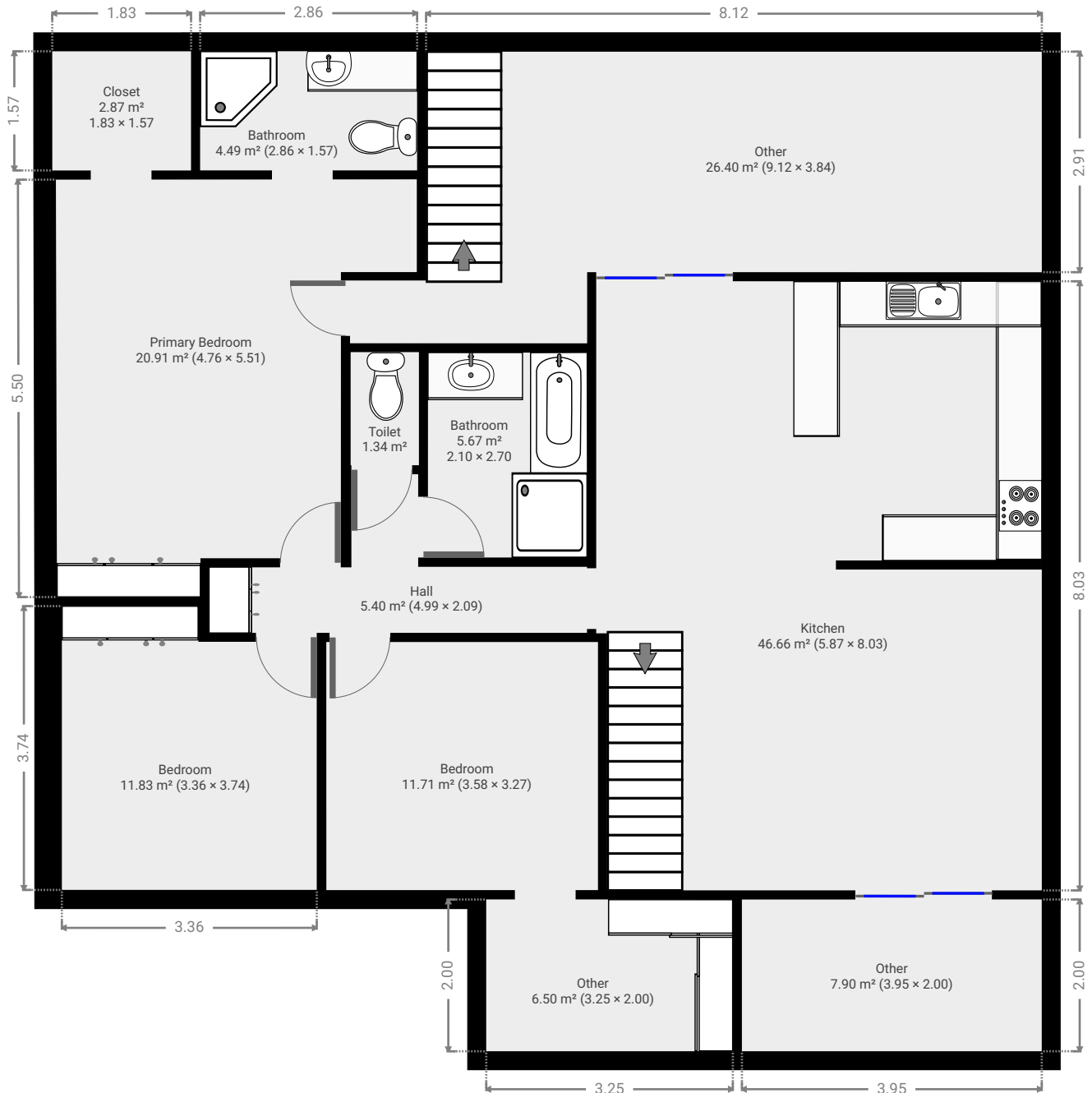

▼ **Bedroom**
1st Floor

WIDTH: 3.36 m • LENGTH: 3.74 m
AREA: 11.83 m² • PERIMETER: 14.20 m

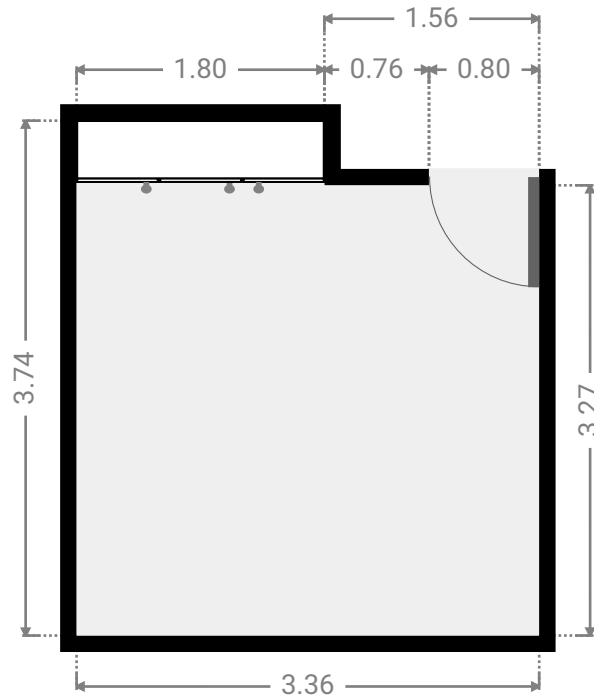
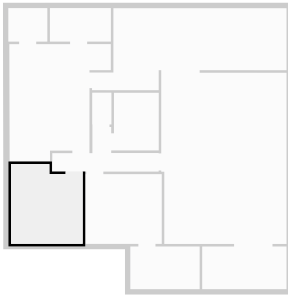

▼ **Hall**
1st Floor

WIDTH: 4.99 m • LENGTH: 2.09 m
AREA: 5.40 m² • PERIMETER: 14.15 m

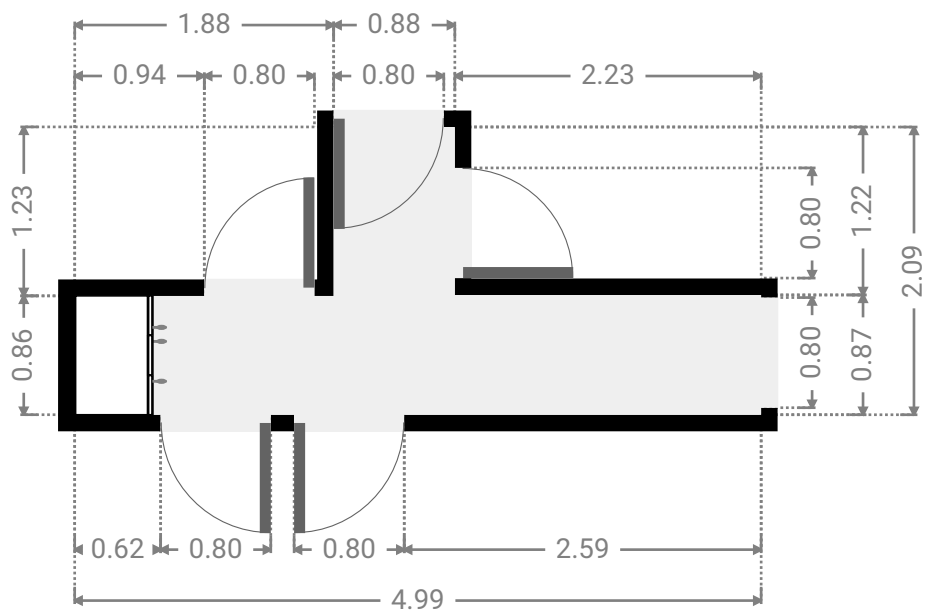
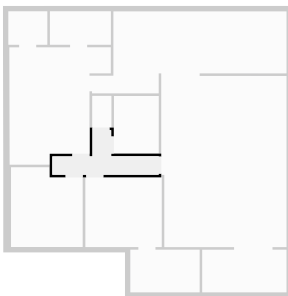

▼ Primary Bedroom
1st Floor

WIDTH: 4.76 m • LENGTH: 5.51 m
AREA: 20.91 m² • PERIMETER: 20.50 m

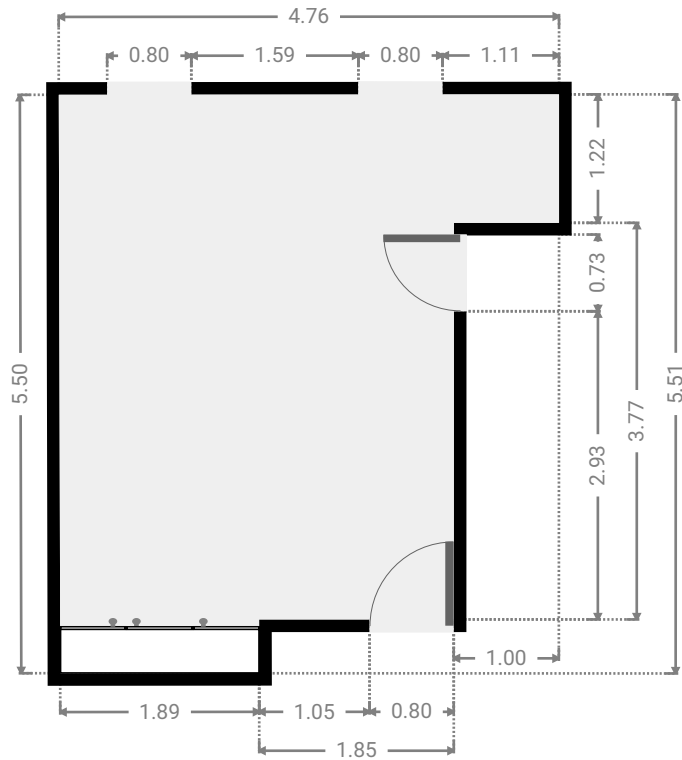
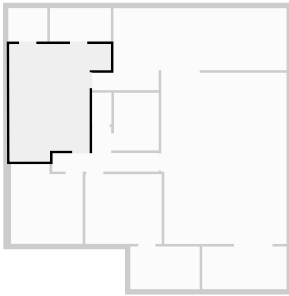

▼ Closet
1st Floor

WIDTH: 1.83 m • LENGTH: 1.57 m
AREA: 2.87 m² • PERIMETER: 6.80 m

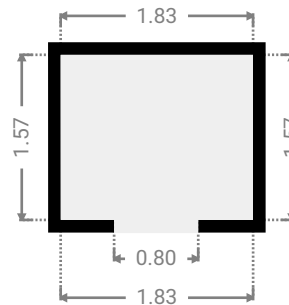
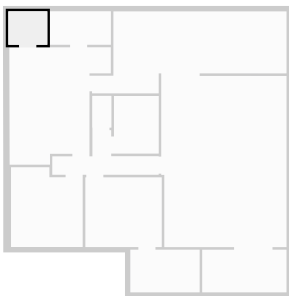

▼ **Bathroom**
1st Floor

WIDTH: 2.86 m • LENGTH: 1.57 m
AREA: 4.49 m² • PERIMETER: 8.86 m

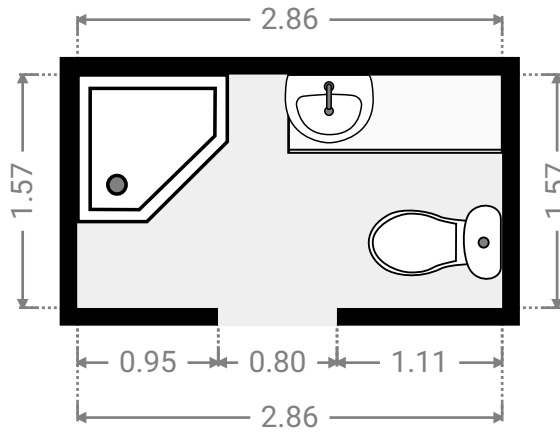
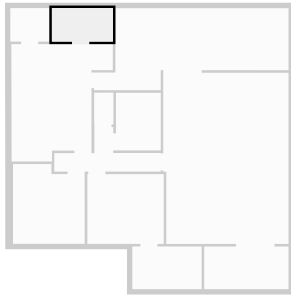

▼ **Bedroom**
1st Floor

WIDTH: 3.58 m • LENGTH: 3.27 m
AREA: 11.71 m² • PERIMETER: 13.70 m

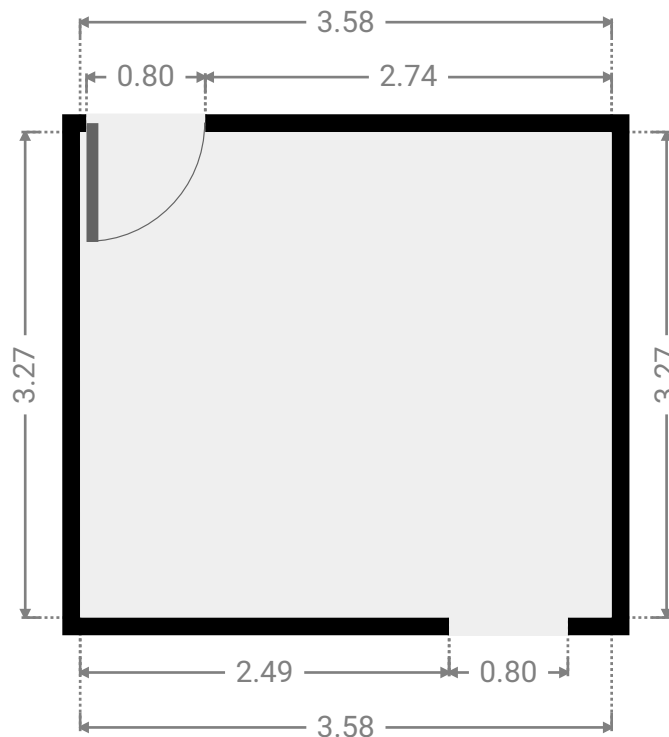
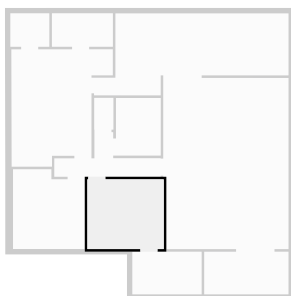

▼ **Other**
1st Floor

WIDTH: 3.25 m • LENGTH: 2.00 m
AREA: 6.50 m² • PERIMETER: 10.50 m

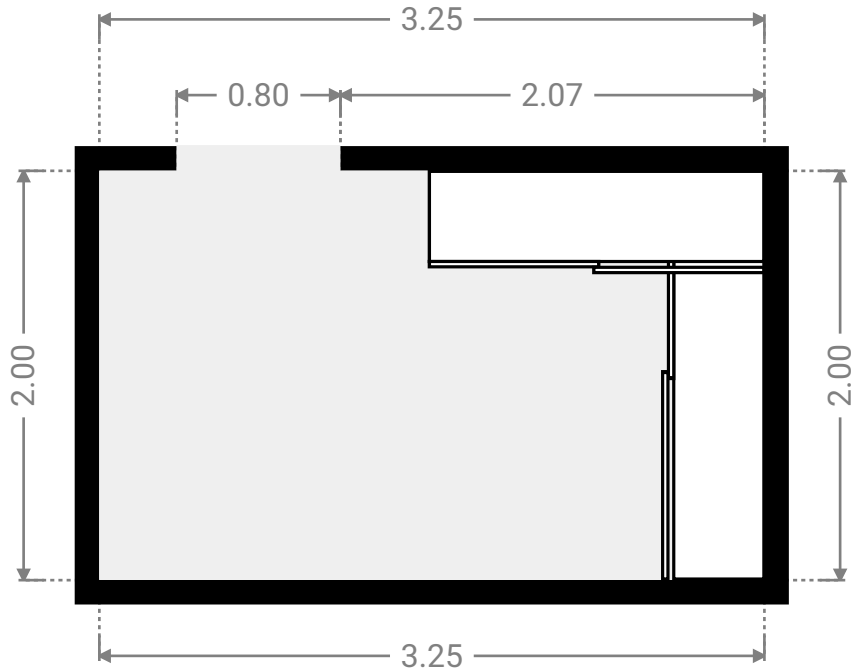
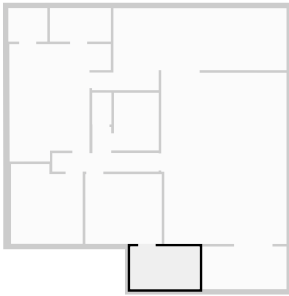

▼ **Toilet**
1st Floor

WIDTH: 0.90 m • LENGTH: 1.49 m
AREA: 1.34 m² • PERIMETER: 4.78 m

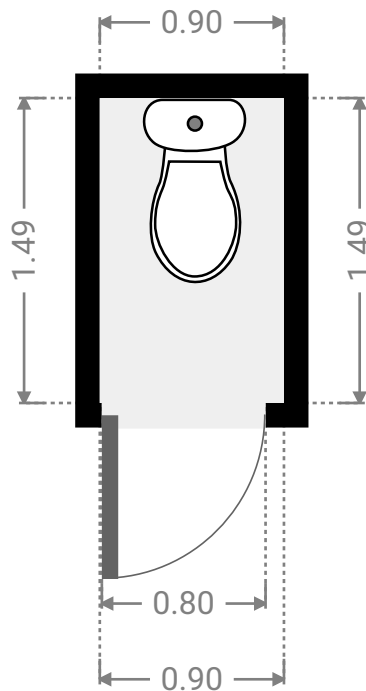
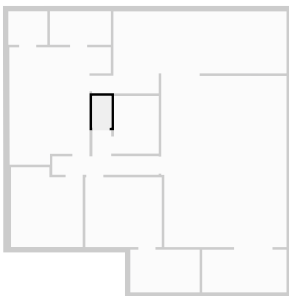

▼ Bathroom
1st Floor

WIDTH: 2.10 m • LENGTH: 2.70 m
AREA: 5.67 m² • PERIMETER: 9.60 m

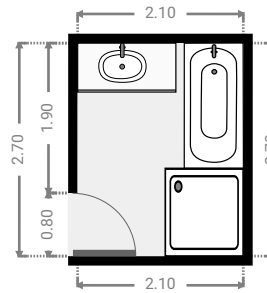
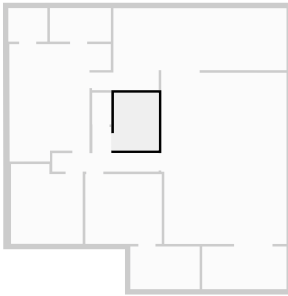

▼ Kitchen
1st Floor

WIDTH: 5.87 m • LENGTH: 8.03 m
AREA: 46.66 m² • PERIMETER: 27.80 m

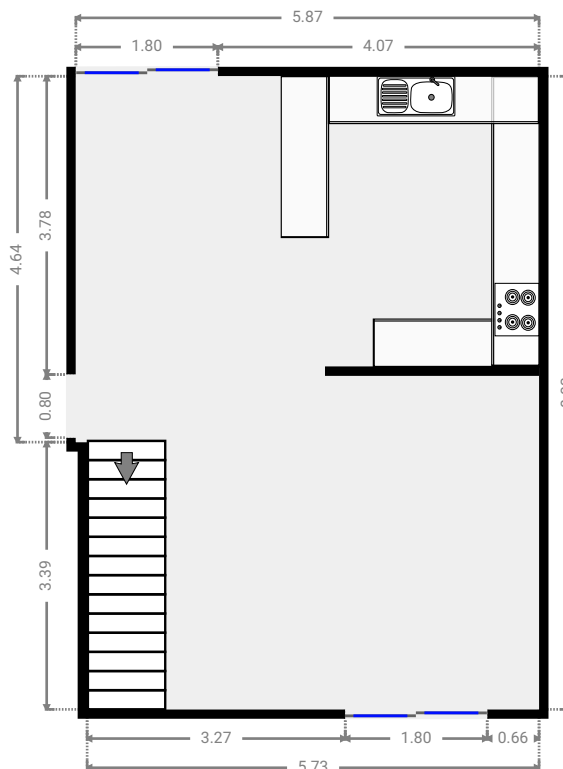
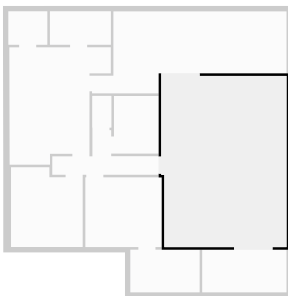

▼ Other
1st Floor

WIDTH: 9.12 m • LENGTH: 3.84 m
AREA: 26.40 m² • PERIMETER: 25.92 m

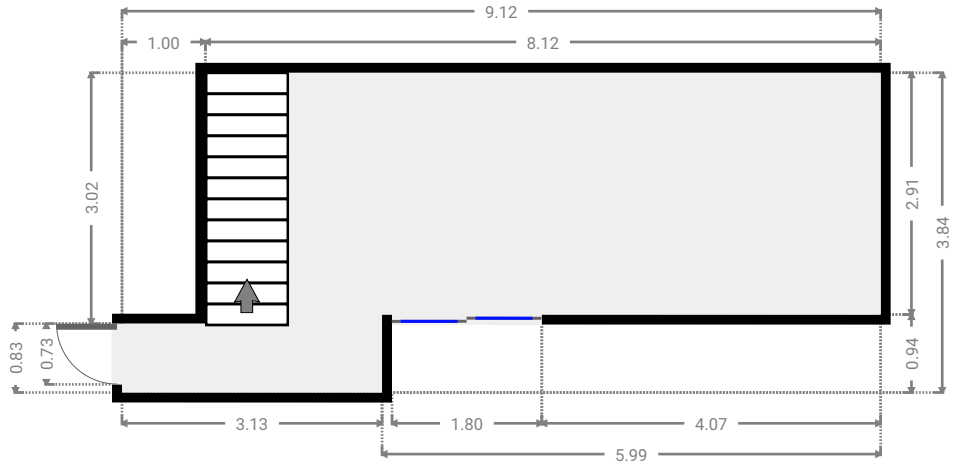
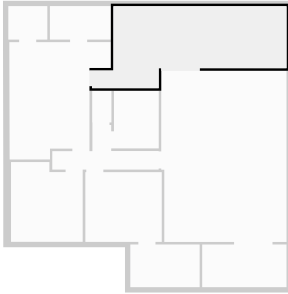

▼ Other
1st Floor

WIDTH: 3.95 m • LENGTH: 2.00 m
AREA: 7.90 m² • PERIMETER: 11.90 m

