

343 Waterloo Street

SUBMITTED BY

Ray White Rockhampton Casey
stockers@cqoz.com

CREATED ON

2021-12-15

Floors

2

▼ Ground Floor

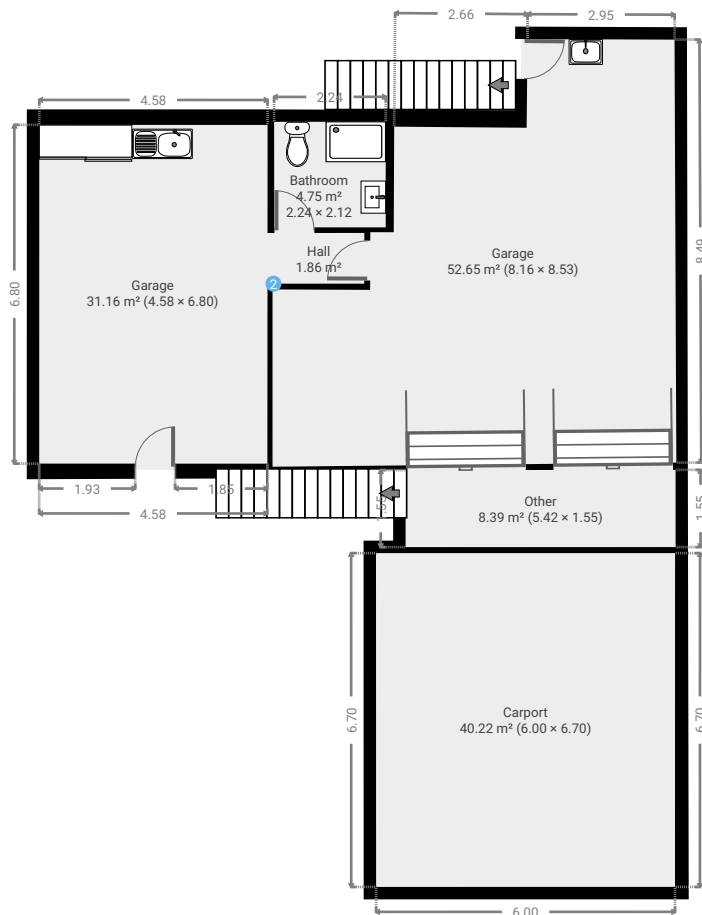
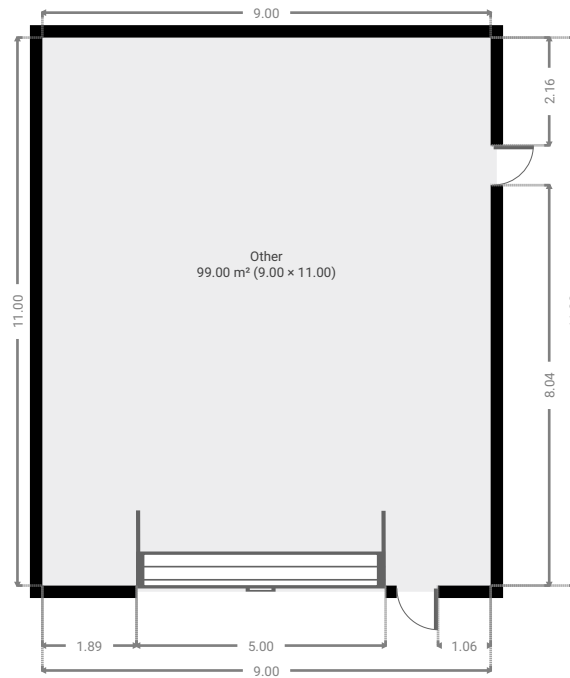

▼ Garage
Ground Floor

WIDTH: 8.15 m • LENGTH: 8.53 m
AREA: 52.65 m² • PERIMETER: 33.26 m

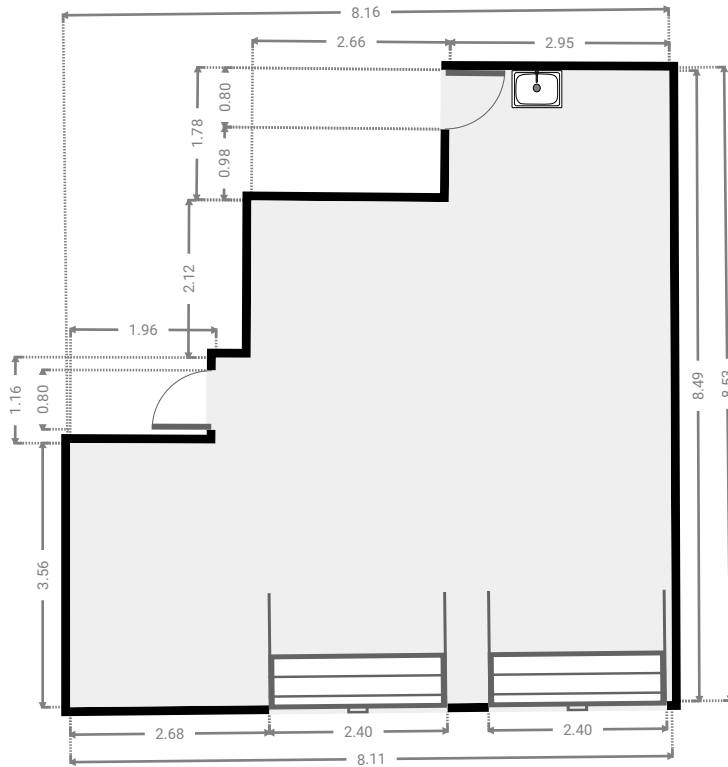

▼ Bathroom
Ground Floor

WIDTH: 2.24 m • LENGTH: 2.12 m
AREA: 4.75 m² • PERIMETER: 8.72 m

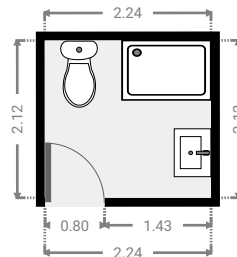
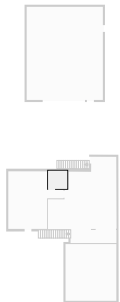

▼ **Garage**
Ground Floor

WIDTH: 4.58 m • LENGTH: 6.80 m
AREA: 31.16 m² • PERIMETER: 22.76 m

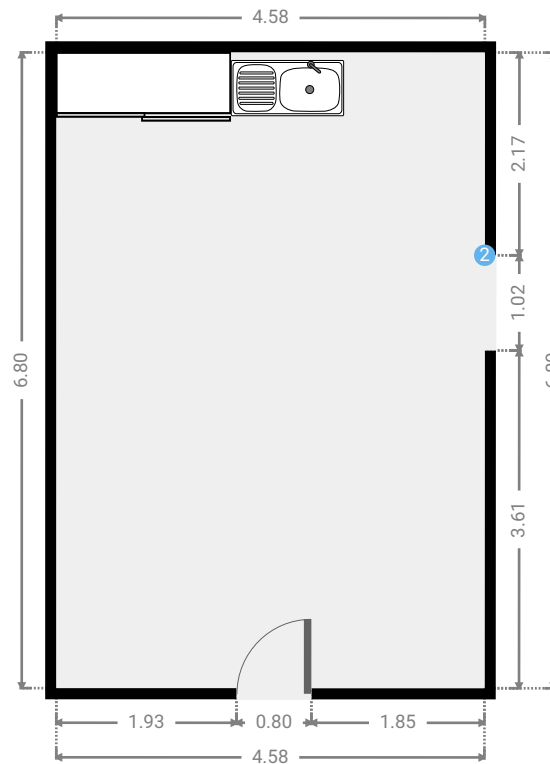
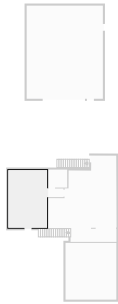

▼ **Hall**
Ground Floor

WIDTH: 1.83 m • LENGTH: 1.02 m
AREA: 1.86 m² • PERIMETER: 5.69 m

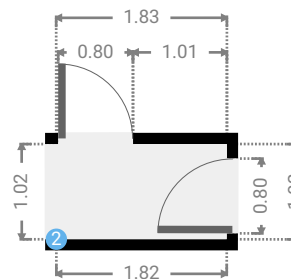

▼ Hall/Ground Floor

2 OPENING

Height
0.00 m



▼ Other
Ground Floor

WIDTH: 9.00 m • LENGTH: 11.00 m
AREA: 99.00 m² • PERIMETER: 40.00 m

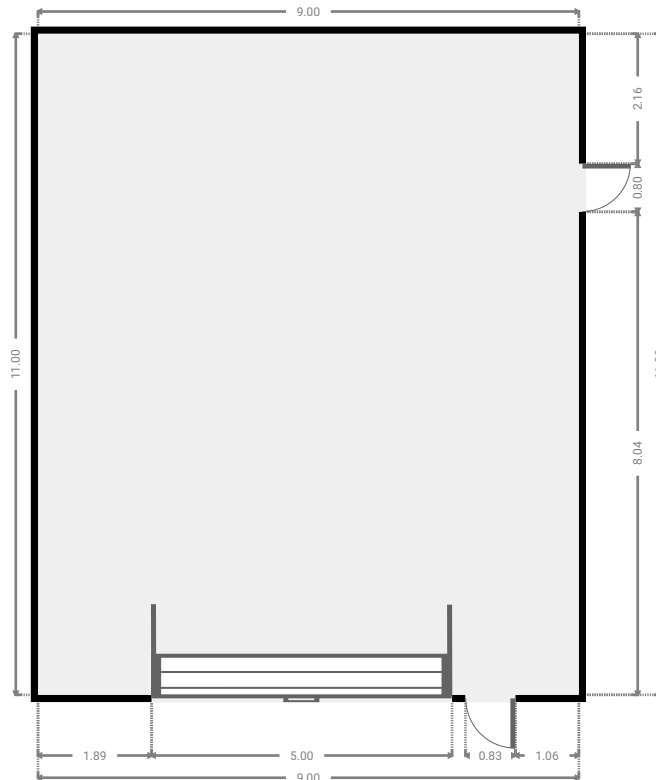
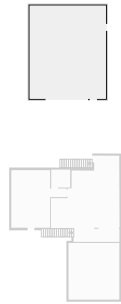

▼ Other
Ground Floor

WIDTH: 5.42 m • LENGTH: 1.55 m
AREA: 8.39 m² • PERIMETER: 13.94 m

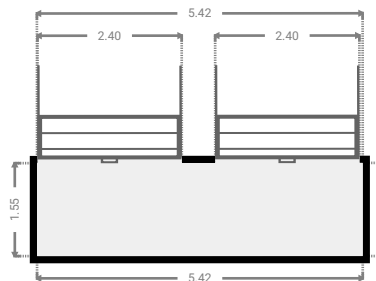
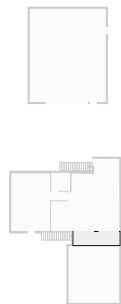

▼ **Carpport**
Ground Floor

WIDTH: 6.01 m • LENGTH: 6.70 m
AREA: 40.22 m² • PERIMETER: 25.41 m

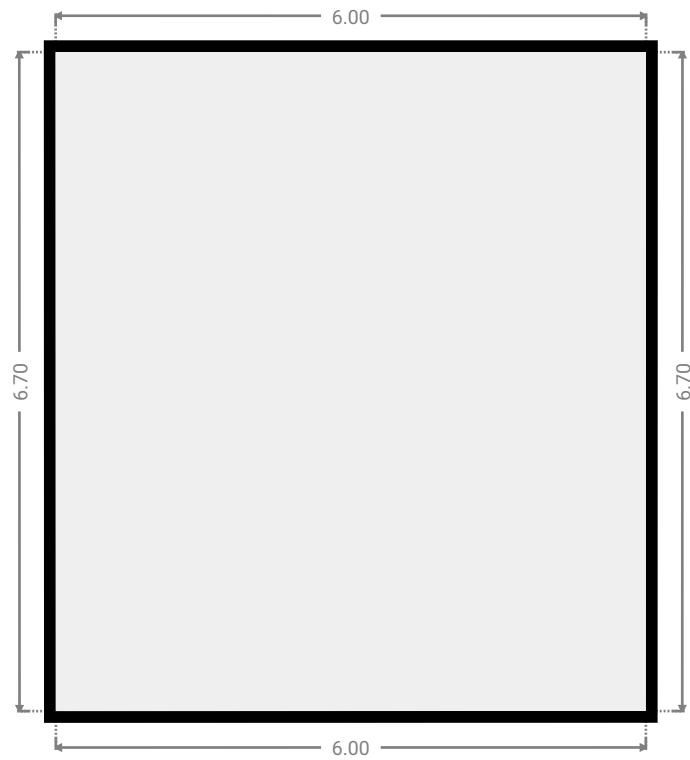
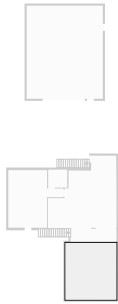

▼ 1st Floor

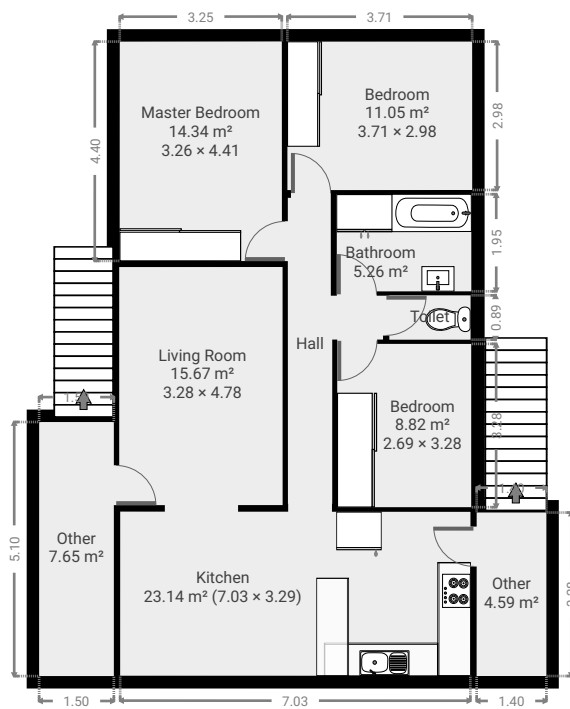

▼ **Living Room**
1st Floor

WIDTH: 4.78 m • LENGTH: 3.28 m
AREA: 15.67 m² • PERIMETER: 16.12 m

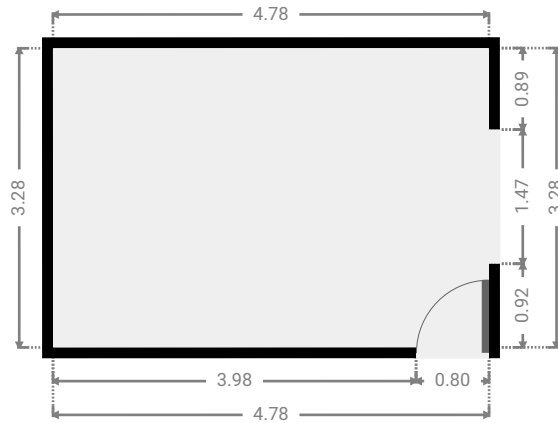
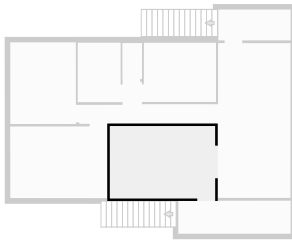

▼ **Kitchen**
1st Floor

WIDTH: 3.29 m • LENGTH: 7.03 m
AREA: 23.14 m² • PERIMETER: 20.64 m

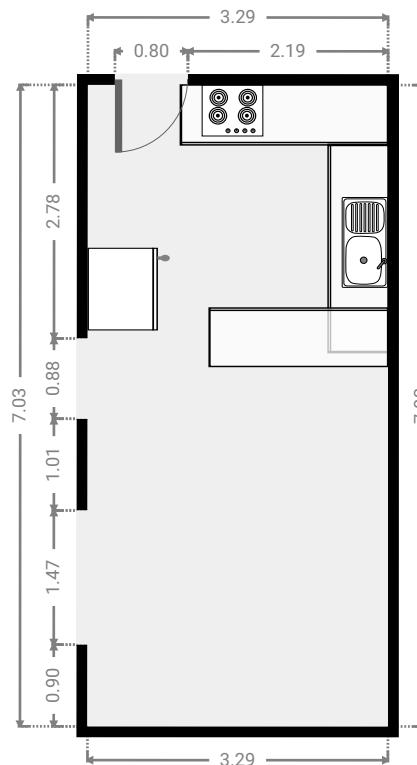
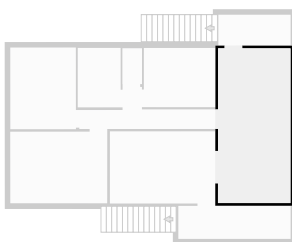

▼ **Hall**
1st Floor

WIDTH: 6.14 m • LENGTH: 1.91 m
AREA: 6.31 m² • PERIMETER: 16.10 m

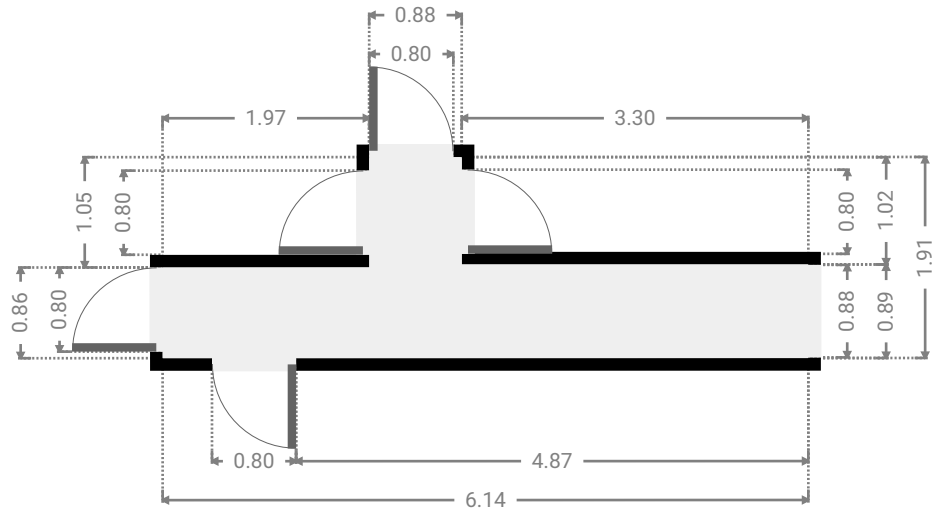
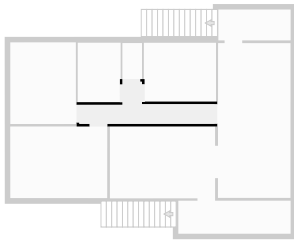

▼ **Bedroom**
1st Floor

WIDTH: 3.28 m • LENGTH: 2.69 m
AREA: 8.82 m² • PERIMETER: 11.94 m

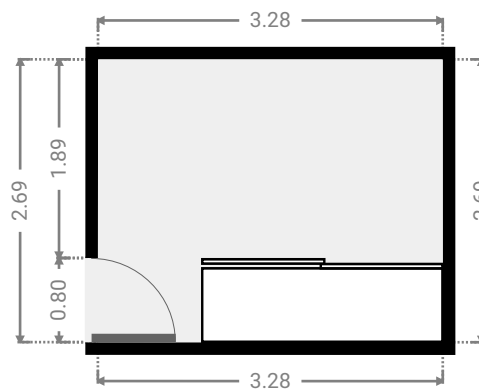
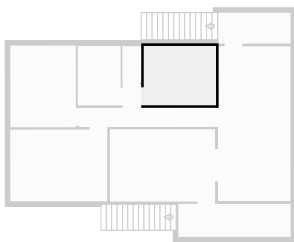

▼ **Toilet**
1st Floor

WIDTH: 0.89 m • LENGTH: 1.63 m
AREA: 1.45 m² • PERIMETER: 5.04 m

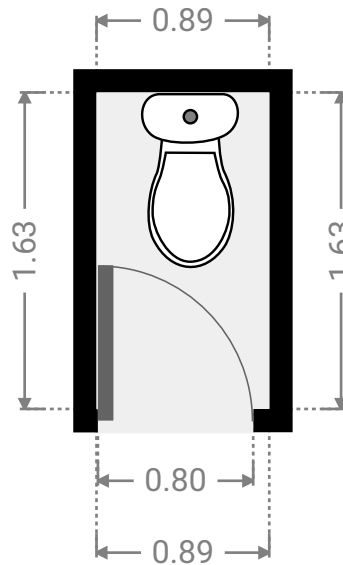
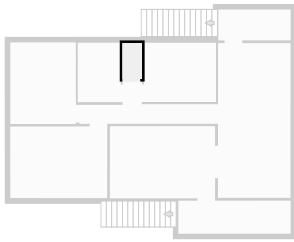

▼ **Bathroom**
1st Floor

WIDTH: 1.95 m • LENGTH: 2.70 m
AREA: 5.26 m² • PERIMETER: 9.30 m

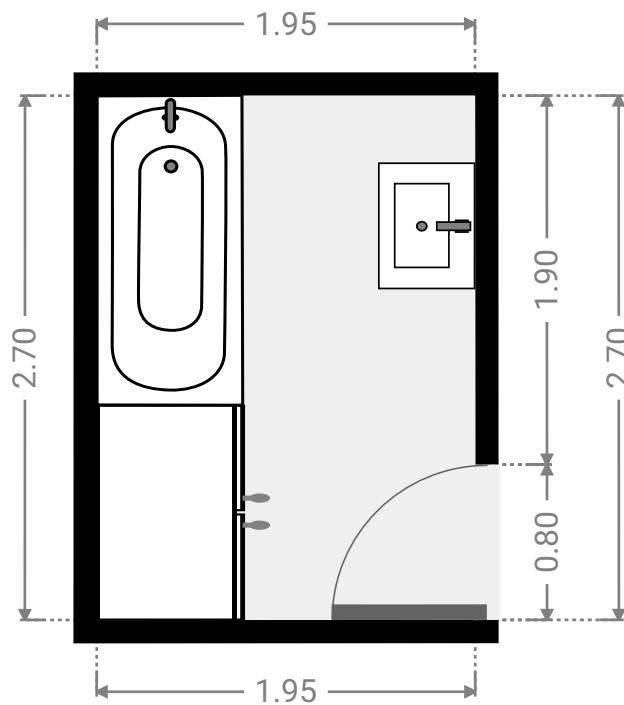
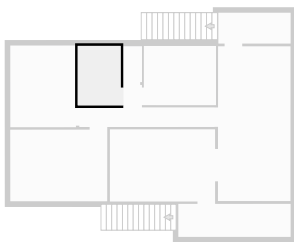

▼ **Bedroom**
1st Floor

WIDTH: 2.98 m • LENGTH: 3.71 m
AREA: 11.05 m² • PERIMETER: 13.38 m

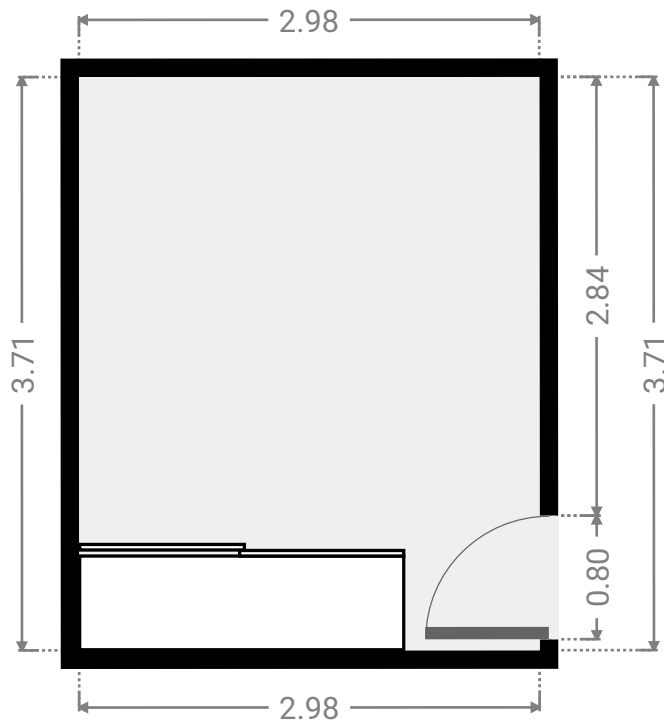
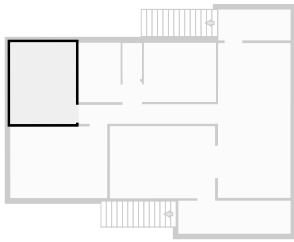

▼ **Master Bedroom**
1st Floor

WIDTH: 4.41 m • LENGTH: 3.26 m
AREA: 14.34 m² • PERIMETER: 15.32 m

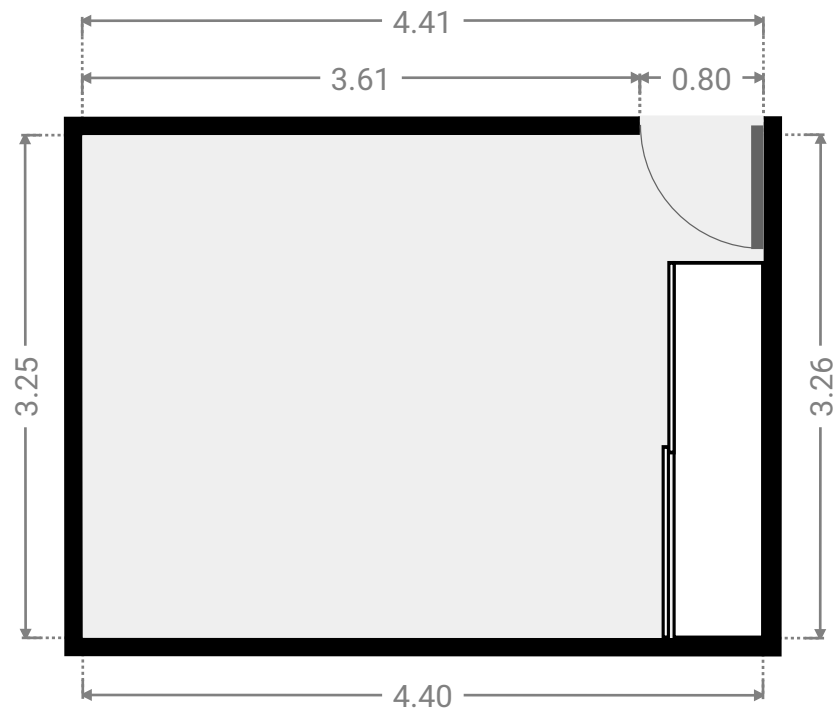
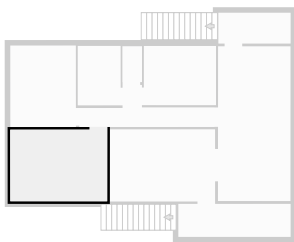

▼ Other
1st Floor

WIDTH: 5.10 m • LENGTH: 1.50 m
AREA: 7.65 m² • PERIMETER: 13.20 m

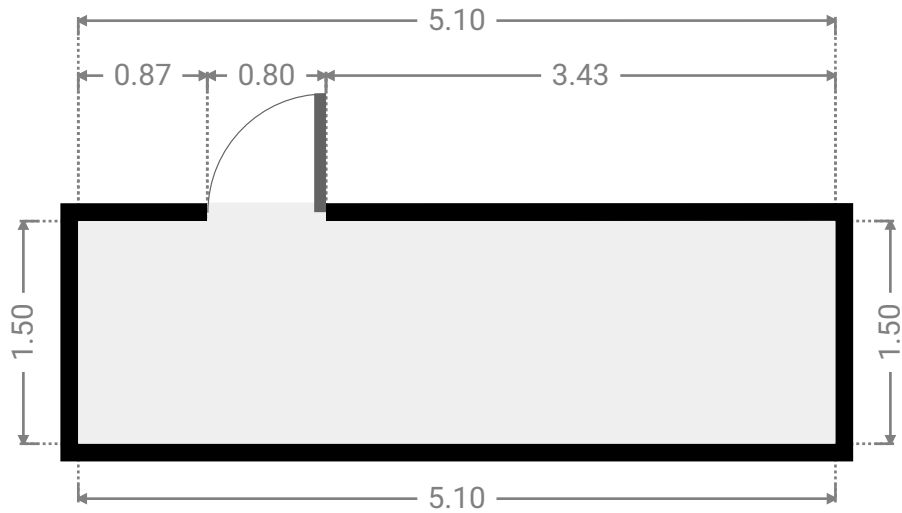
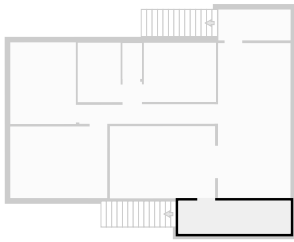

▼ Other
1st Floor

WIDTH: 3.28 m • LENGTH: 1.40 m
AREA: 4.59 m² • PERIMETER: 9.36 m

