

# 334 George Street

**SUBMITTED BY**  
Ray White Rockhampton Casey  
stockers@cqoz.com

---

**CREATED ON**  
2022-05-25

---

**Floors**  
2

---

▼ Ground Floor

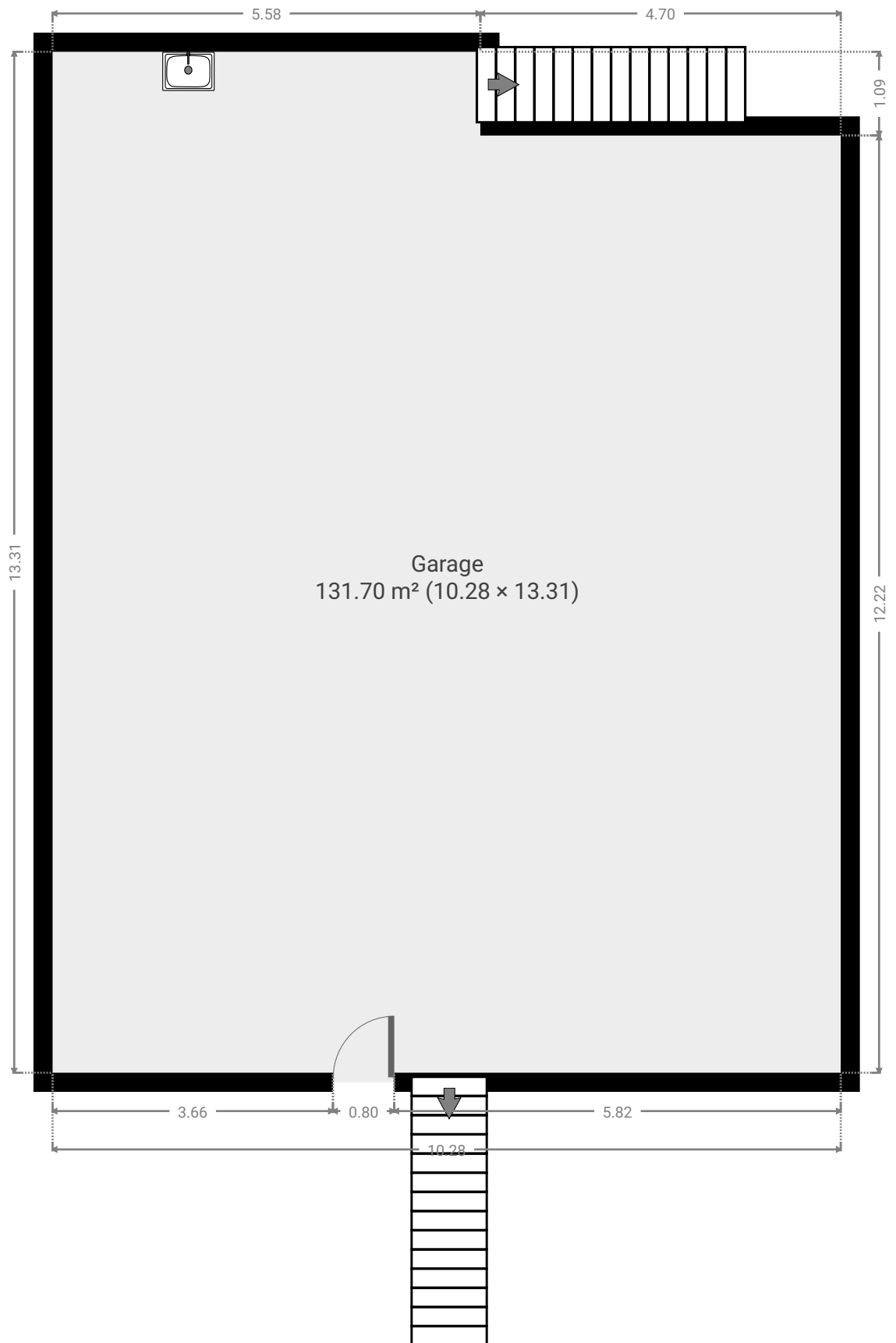

▼ **Garage**  
Ground Floor

WIDTH: 10.28 m • LENGTH: 13.31 m  
AREA: 131.70 m<sup>2</sup> • PERIMETER: 47.18 m

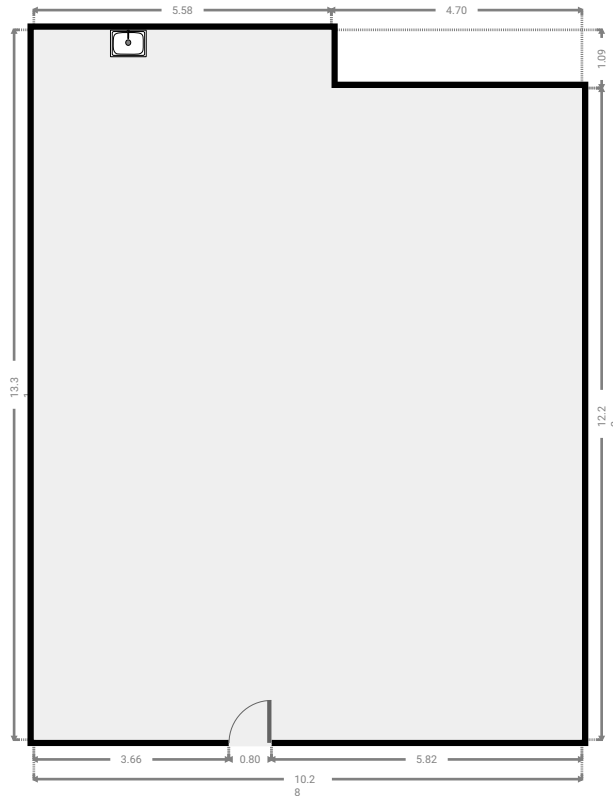
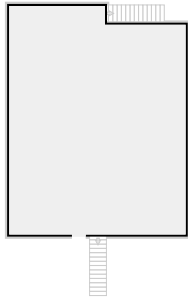

▼ 1st Floor

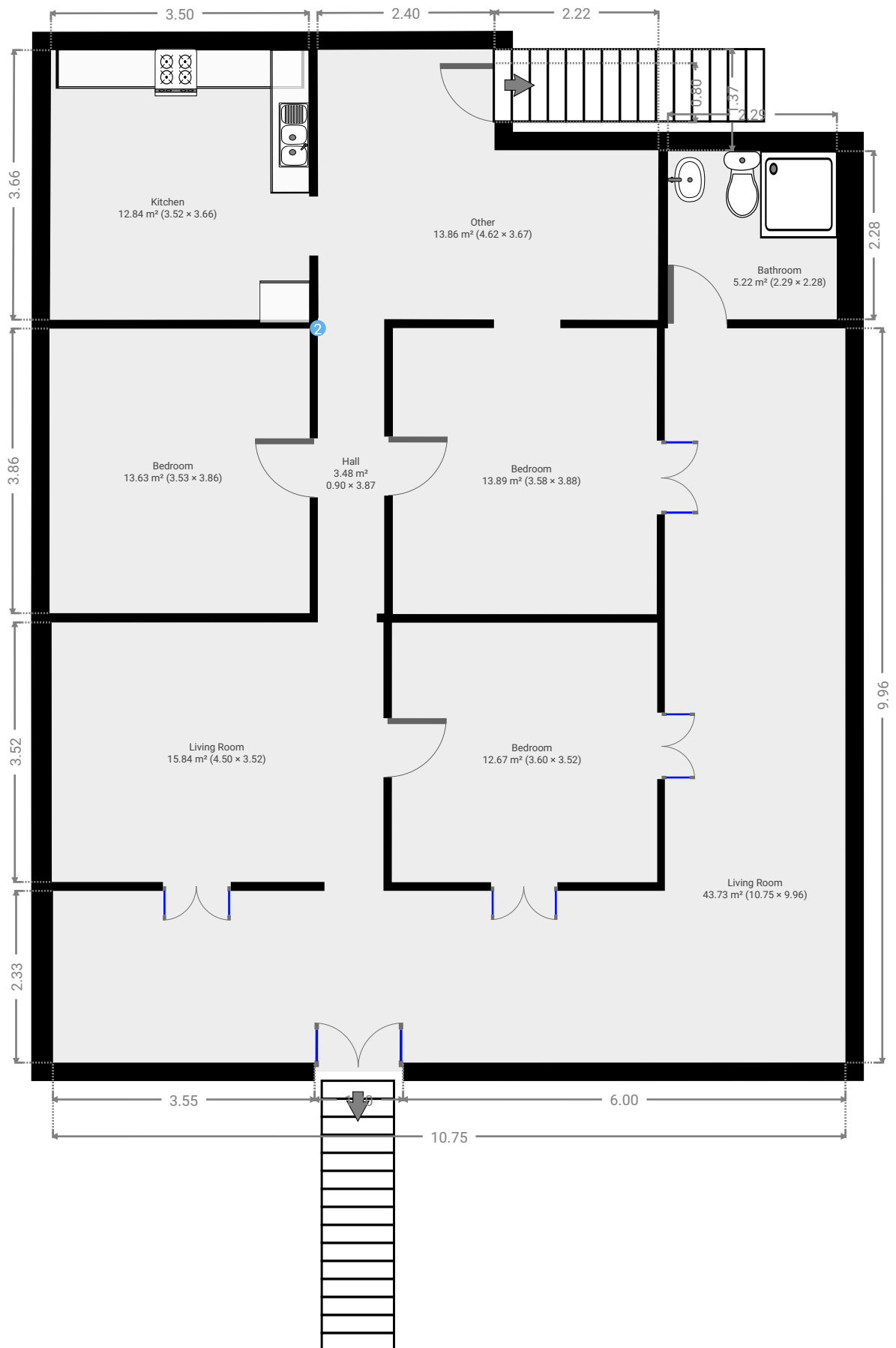

▼ Bathroom  
1st Floor

WIDTH: 2.29 m • LENGTH: 2.28 m  
AREA: 5.22 m<sup>2</sup> • PERIMETER: 9.14 m

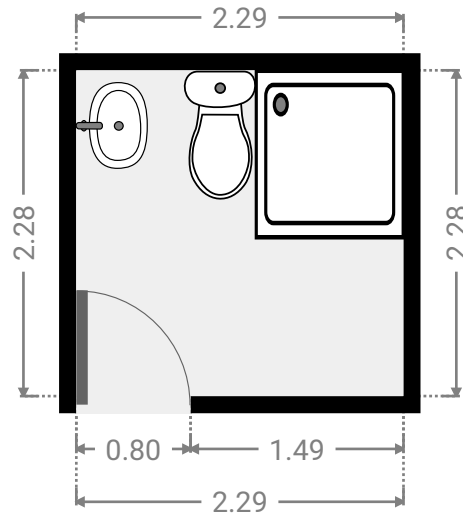
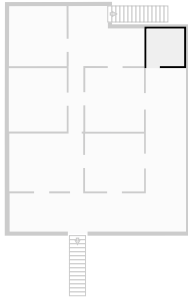

▼ Bedroom  
1st Floor

WIDTH: 3.60 m • LENGTH: 3.52 m  
AREA: 12.67 m<sup>2</sup> • PERIMETER: 14.24 m

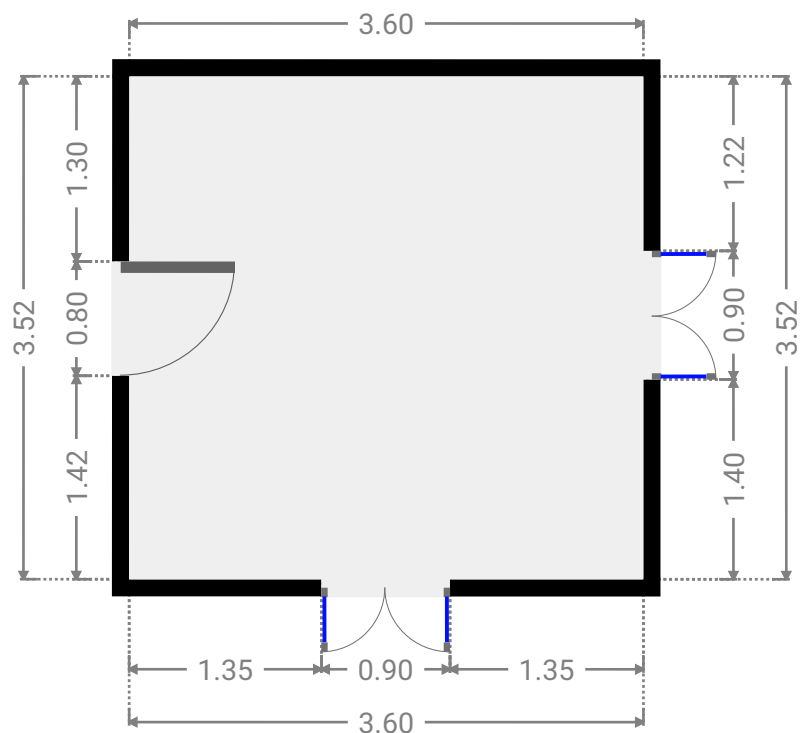
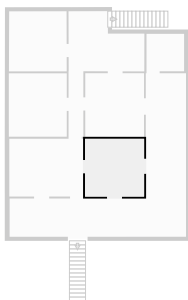

▼ **Bedroom**  
1st Floor

WIDTH: 3.58 m • LENGTH: 3.88 m  
AREA: 13.89 m<sup>2</sup> • PERIMETER: 14.92 m

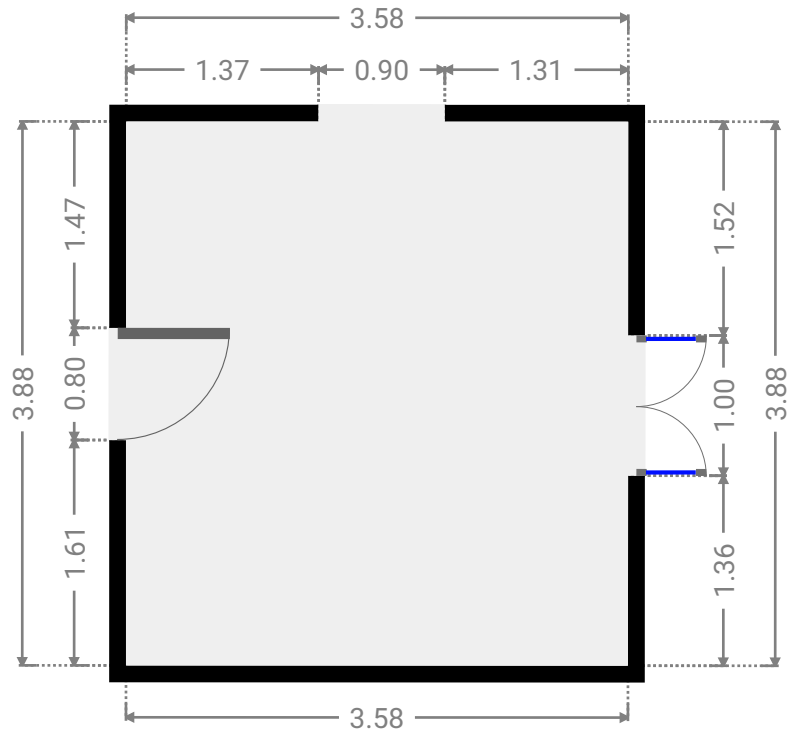
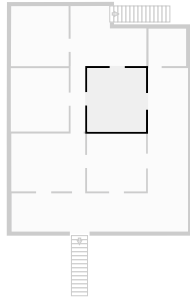

▼ **Bedroom**  
1st Floor

WIDTH: 3.53 m • LENGTH: 3.86 m  
AREA: 13.63 m<sup>2</sup> • PERIMETER: 14.78 m

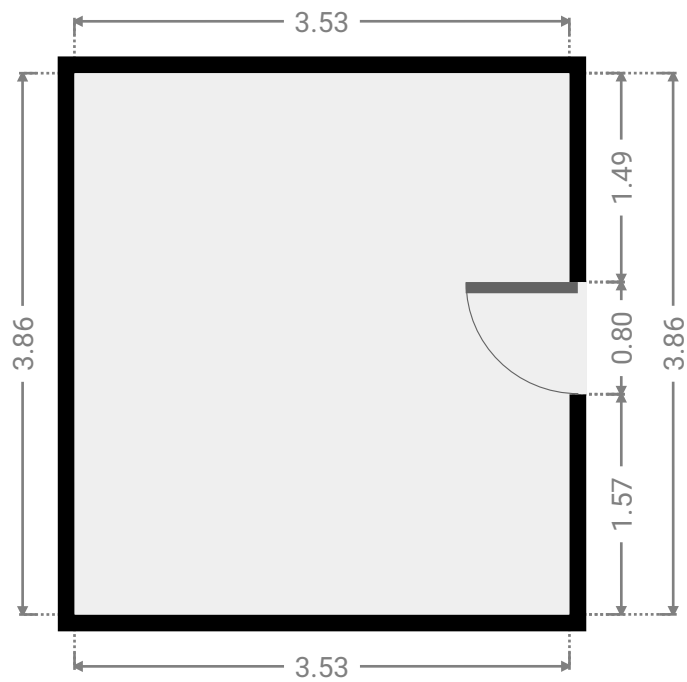
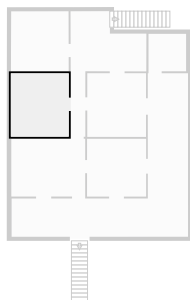

▼ **Hall**  
1st Floor

WIDTH: 0.90 m • LENGTH: 3.87 m  
AREA: 3.48 m<sup>2</sup> • PERIMETER: 9.54 m

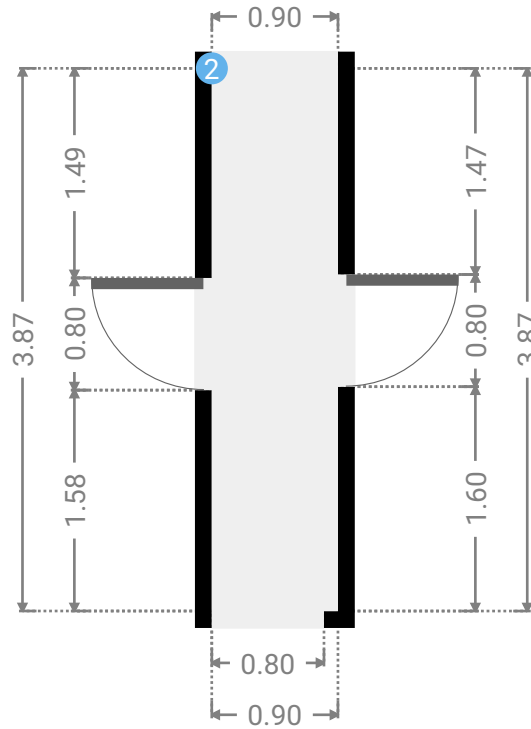
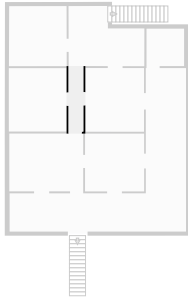

▼ **Hall/1st Floor**

**2** OPENING

Height  
0.00 m



▼ Kitchen  
1st Floor

WIDTH: 3.52 m • LENGTH: 3.66 m  
AREA: 12.84 m<sup>2</sup> • PERIMETER: 14.33 m

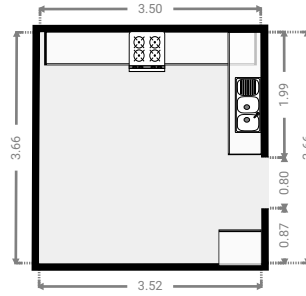
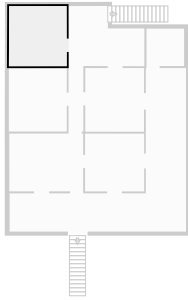

▼ Living Room  
1st Floor

WIDTH: 10.75 m • LENGTH: 9.96 m  
AREA: 43.73 m<sup>2</sup> • PERIMETER: 41.42 m

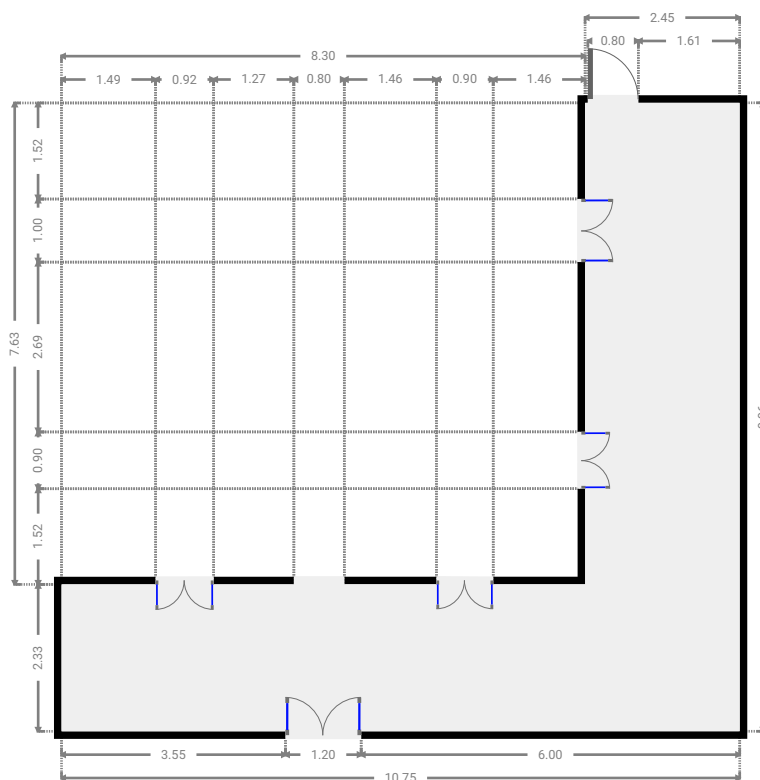
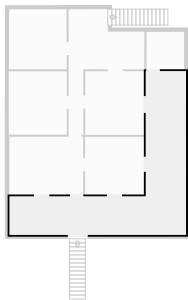



▼ Living Room  
1st Floor

WIDTH: 4.50 m • LENGTH: 3.52 m  
AREA: 15.84 m<sup>2</sup> • PERIMETER: 16.04 m

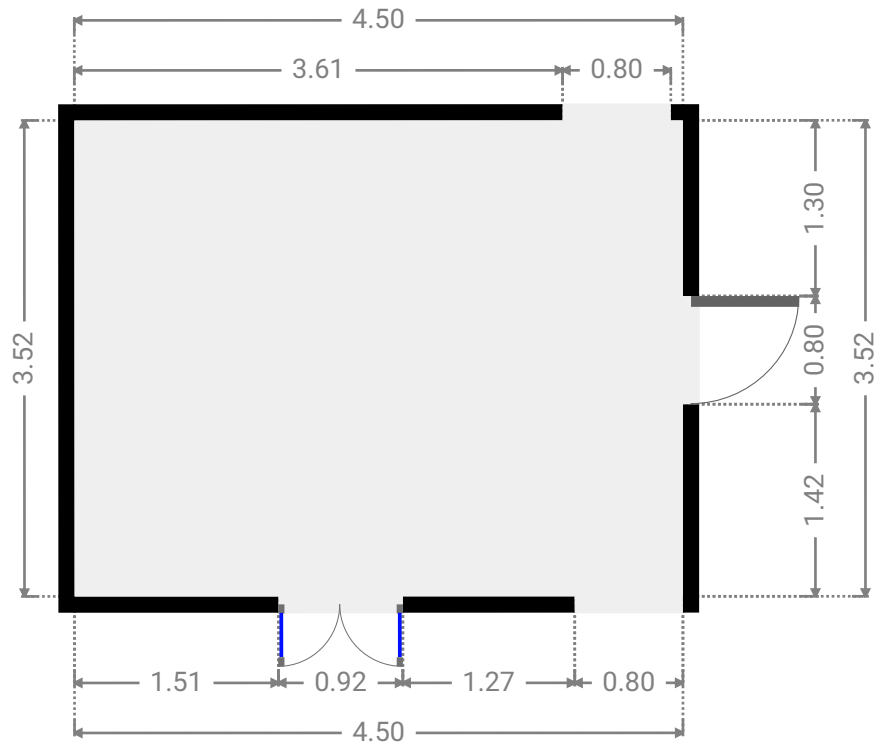
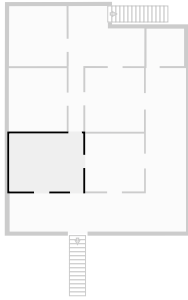

▼ Other  
1st Floor

WIDTH: 4.62 m • LENGTH: 3.67 m  
AREA: 13.86 m<sup>2</sup> • PERIMETER: 16.55 m

