

33 Lamb Avenue

Created on
2021-05-26

Floors
1

▼ Ground Floor



▼ **Hall**
Ground Floor

WIDTH: 1.76 m • LENGTH: 6.75 m
AREA: 8.91 m² • PERIMETER: 17.00 m

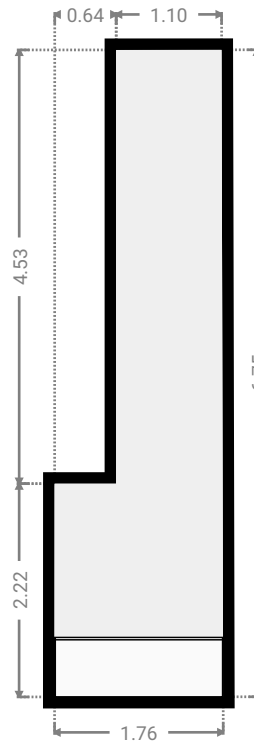
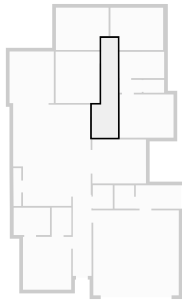

▼ **Closet**
Ground Floor

WIDTH: 0.54 m • LENGTH: 2.57 m
AREA: 1.35 m² • PERIMETER: 6.18 m

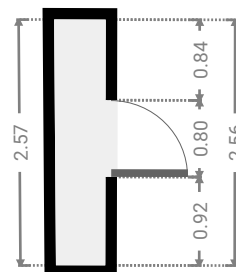
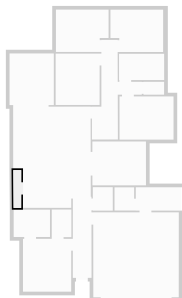

▼ Other
Ground Floor

WIDTH: 3.00 m • LENGTH: 3.50 m
AREA: 10.50 m² • PERIMETER: 13.00 m

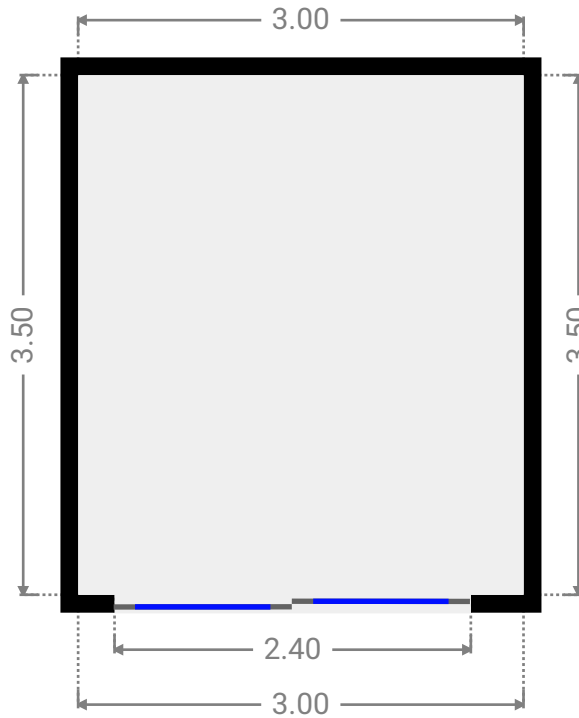
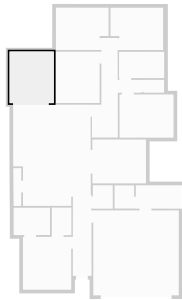

▼ Bedroom
Ground Floor

WIDTH: 3.66 m • LENGTH: 2.93 m
AREA: 10.72 m² • PERIMETER: 13.18 m

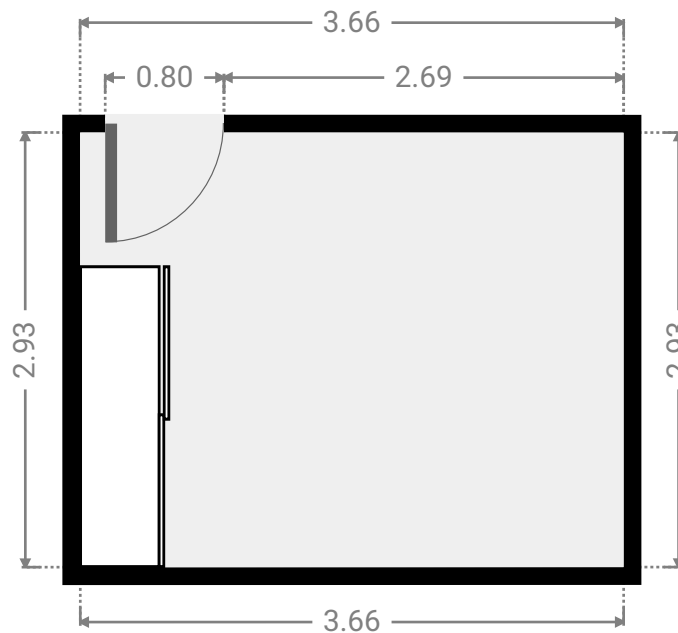
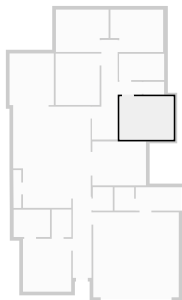

▼ **Toilet**
Ground Floor

WIDTH: 1.40 m • LENGTH: 0.87 m
AREA: 1.22 m² • PERIMETER: 4.54 m

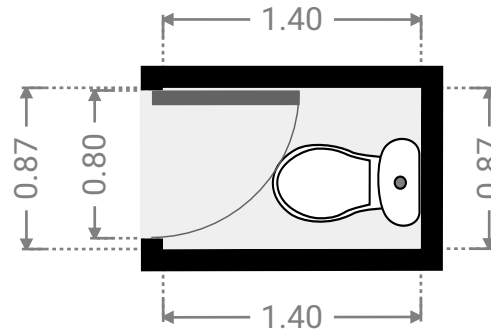
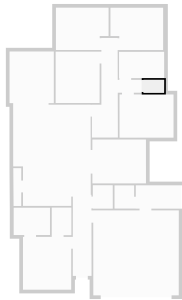

▼ **Hall**
Ground Floor

WIDTH: 1.52 m • LENGTH: 0.87 m
AREA: 1.32 m² • PERIMETER: 4.78 m

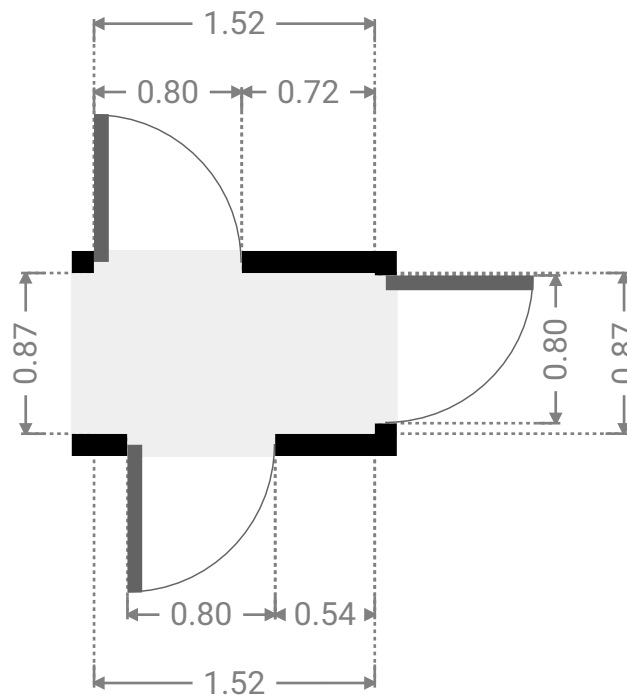
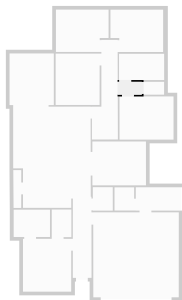

▼ **Bathroom**
Ground Floor

WIDTH: 3.06 m • LENGTH: 1.78 m
AREA: 5.45 m² • PERIMETER: 9.68 m

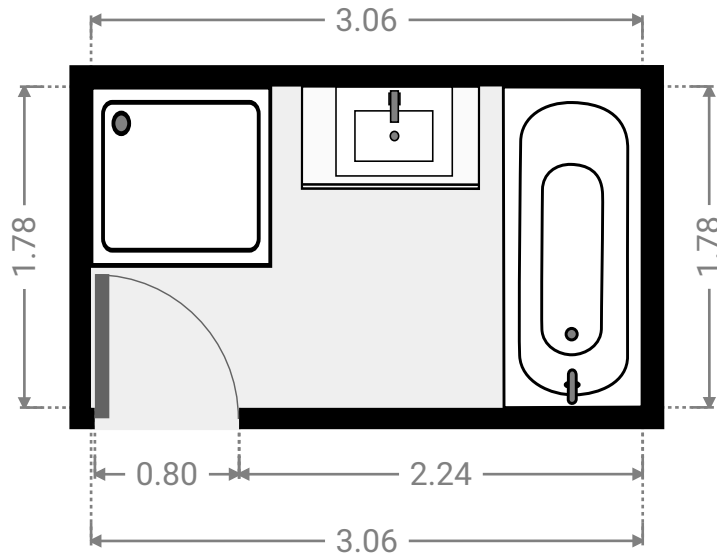
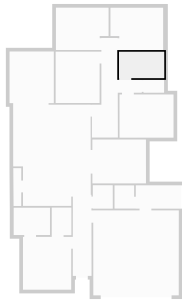

▼ **Bedroom**
Ground Floor

WIDTH: 3.57 m • LENGTH: 2.87 m
AREA: 9.68 m² • PERIMETER: 12.88 m

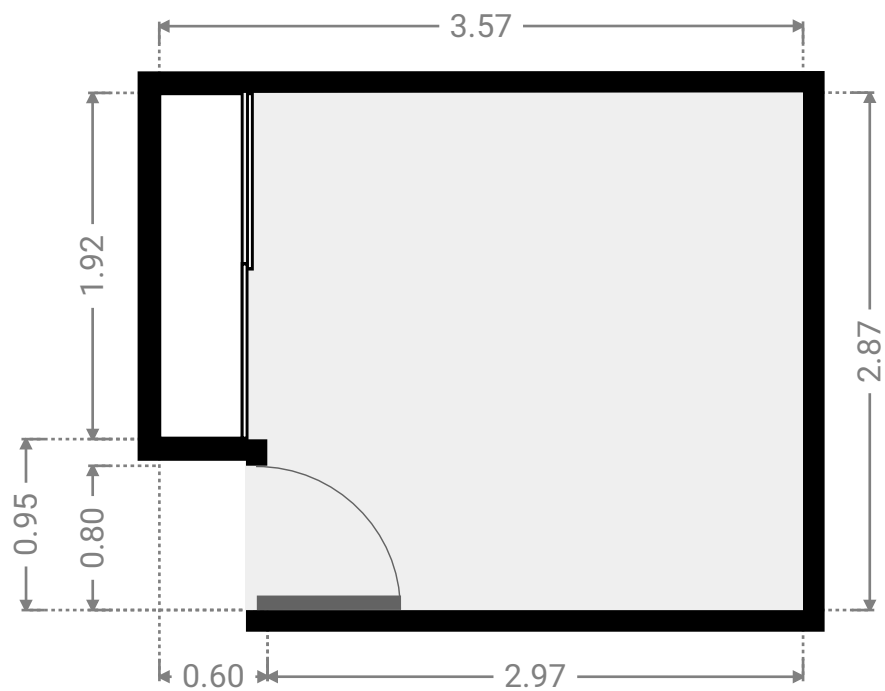
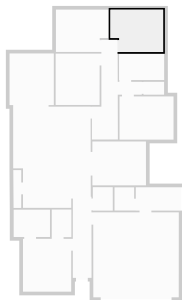

▼ **Bedroom**
Ground Floor

WIDTH: 3.57 m • LENGTH: 2.87 m
AREA: 9.67 m² • PERIMETER: 12.88 m

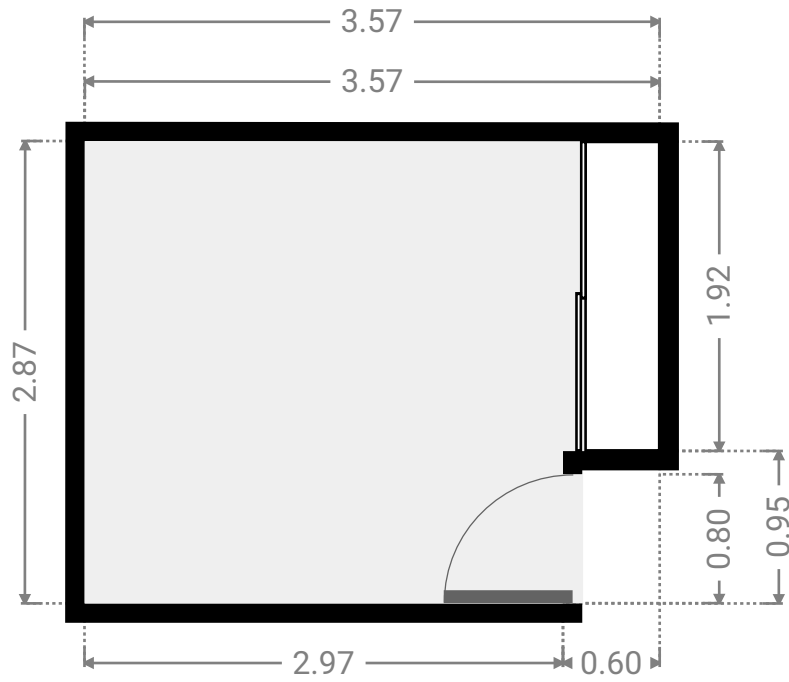
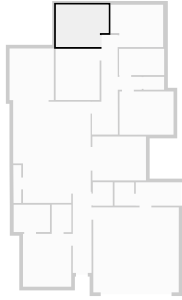

▼ **Bedroom**
Ground Floor

WIDTH: 2.98 m • LENGTH: 3.48 m
AREA: 10.37 m² • PERIMETER: 12.92 m

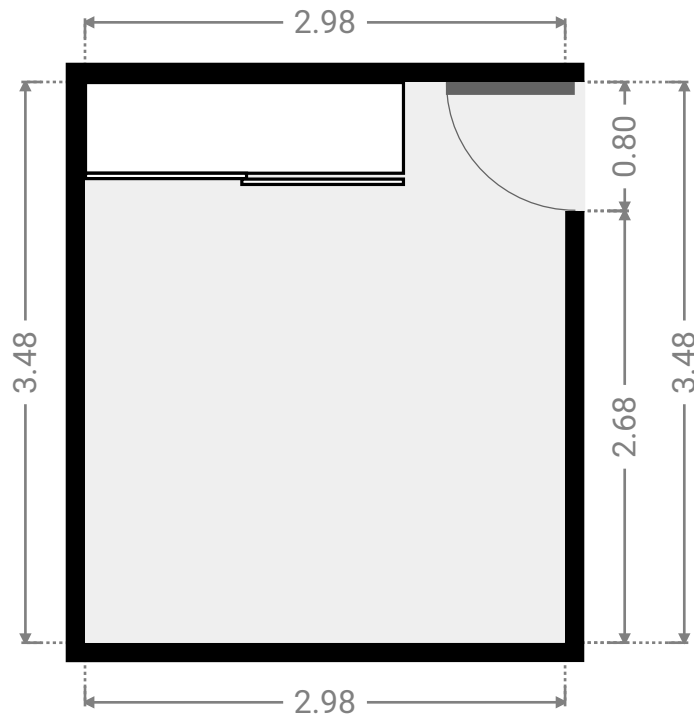
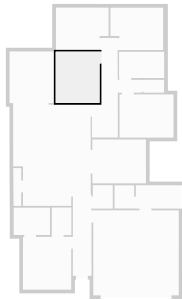

▼ Hall
Ground Floor

WIDTH: 1.27 m • LENGTH: 5.38 m
AREA: 6.80 m² • PERIMETER: 13.29 m

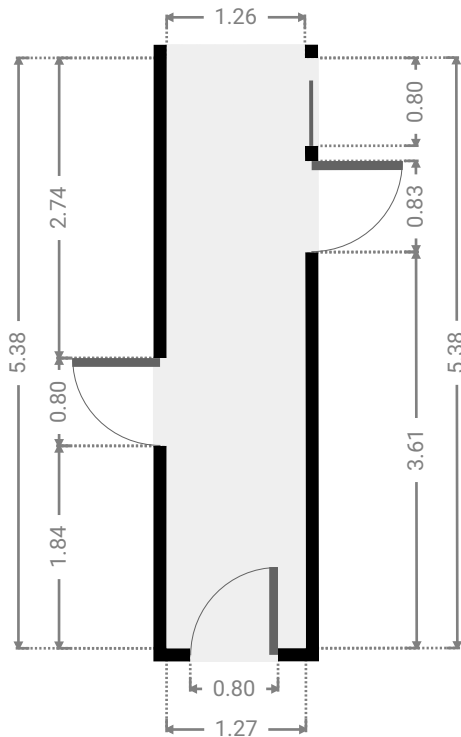

▼ Living Room
Ground Floor

WIDTH: 3.63 m • LENGTH: 2.97 m
AREA: 10.79 m² • PERIMETER: 13.20 m

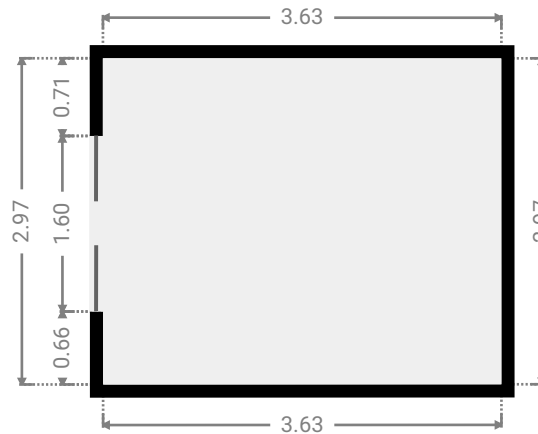
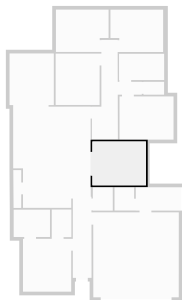

▼ Kitchen
Ground Floor

WIDTH: 5.26 m • LENGTH: 6.86 m
AREA: 33.27 m² • PERIMETER: 24.23 m

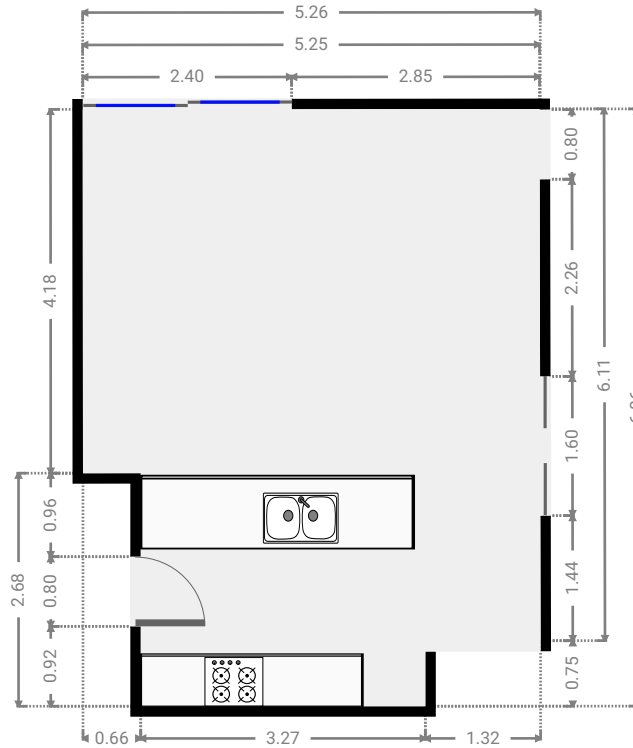
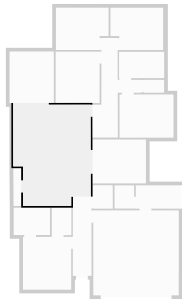

▼ Closet
Ground Floor

WIDTH: 1.35 m • LENGTH: 1.59 m
AREA: 2.14 m² • PERIMETER: 5.87 m

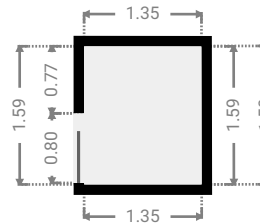
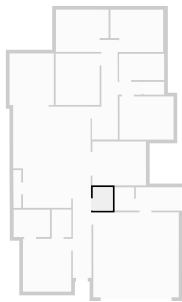

▼ **Closet**
Ground Floor

WIDTH: 1.33 m • LENGTH: 1.57 m
AREA: 2.09 m² • PERIMETER: 5.80 m

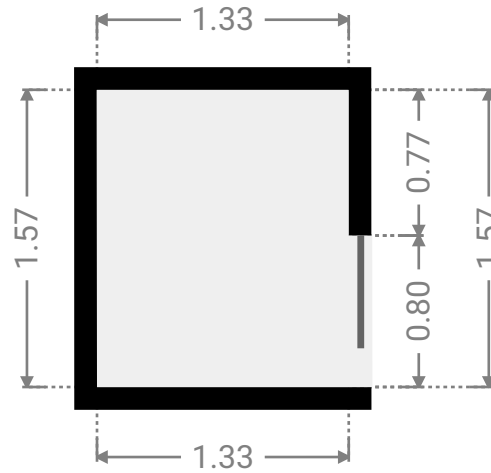
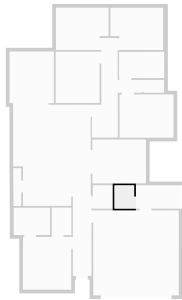

▼ **Laundry Room**
Ground Floor

WIDTH: 2.95 m • LENGTH: 1.58 m
AREA: 4.66 m² • PERIMETER: 9.06 m

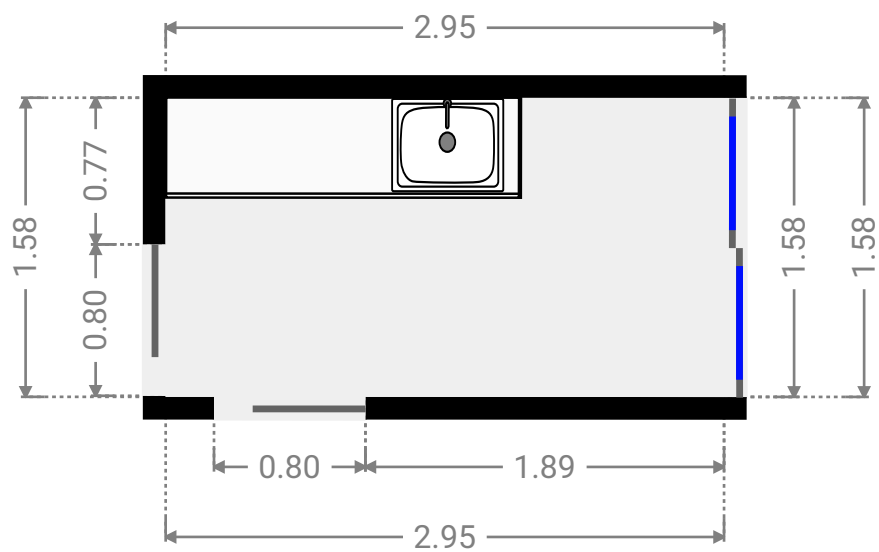
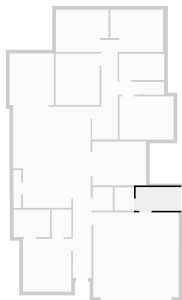

▼ **Garage**
Ground Floor

WIDTH: 5.80 m • LENGTH: 5.76 m
AREA: 33.38 m² • PERIMETER: 23.11 m

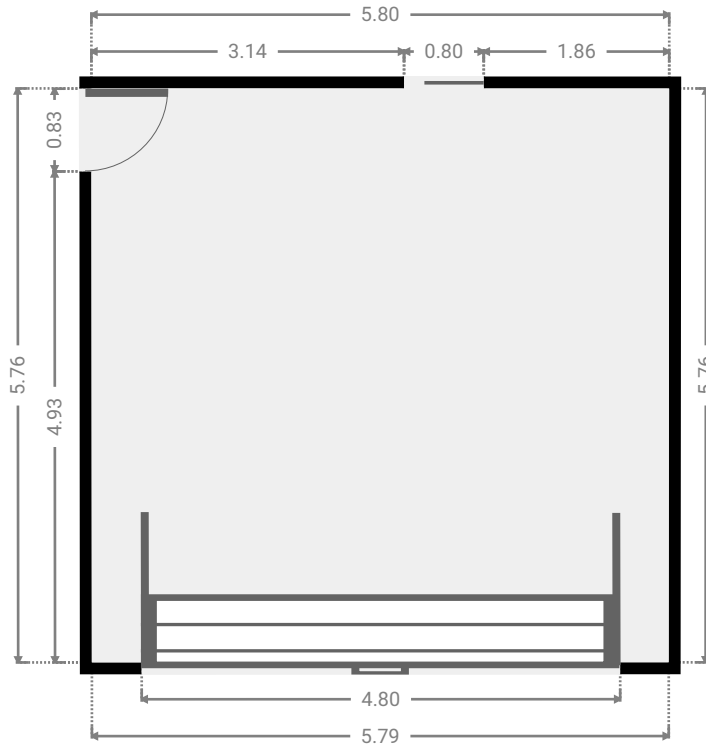
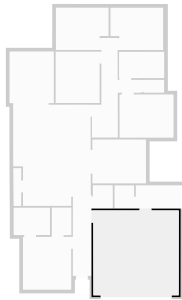

▼ **Bathroom**
Ground Floor

WIDTH: 2.46 m • LENGTH: 1.85 m
AREA: 4.55 m² • PERIMETER: 8.62 m

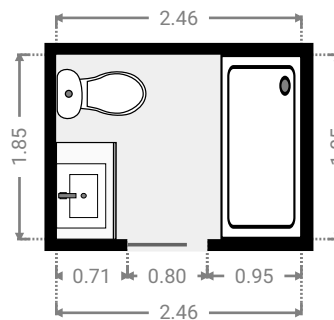
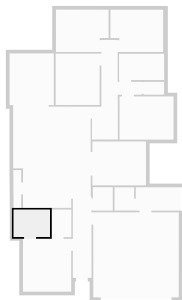

▼ **Closet**
Ground Floor

WIDTH: 1.33 m • LENGTH: 1.87 m
AREA: 2.49 m² • PERIMETER: 6.40 m

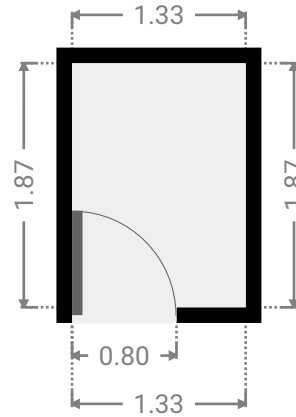
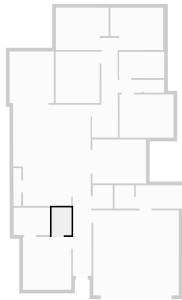

▼ **Master Bedroom**
Ground Floor

WIDTH: 3.27 m • LENGTH: 3.58 m
AREA: 11.71 m² • PERIMETER: 13.70 m

