

# 321 Salamanca street

**SUBMITTED BY**

Ray White Rockhampton Casey  
stockers@cqoz.com

---

**CREATED ON**

2022-03-16

---

**Floors**

2

---

▼ Ground Floor

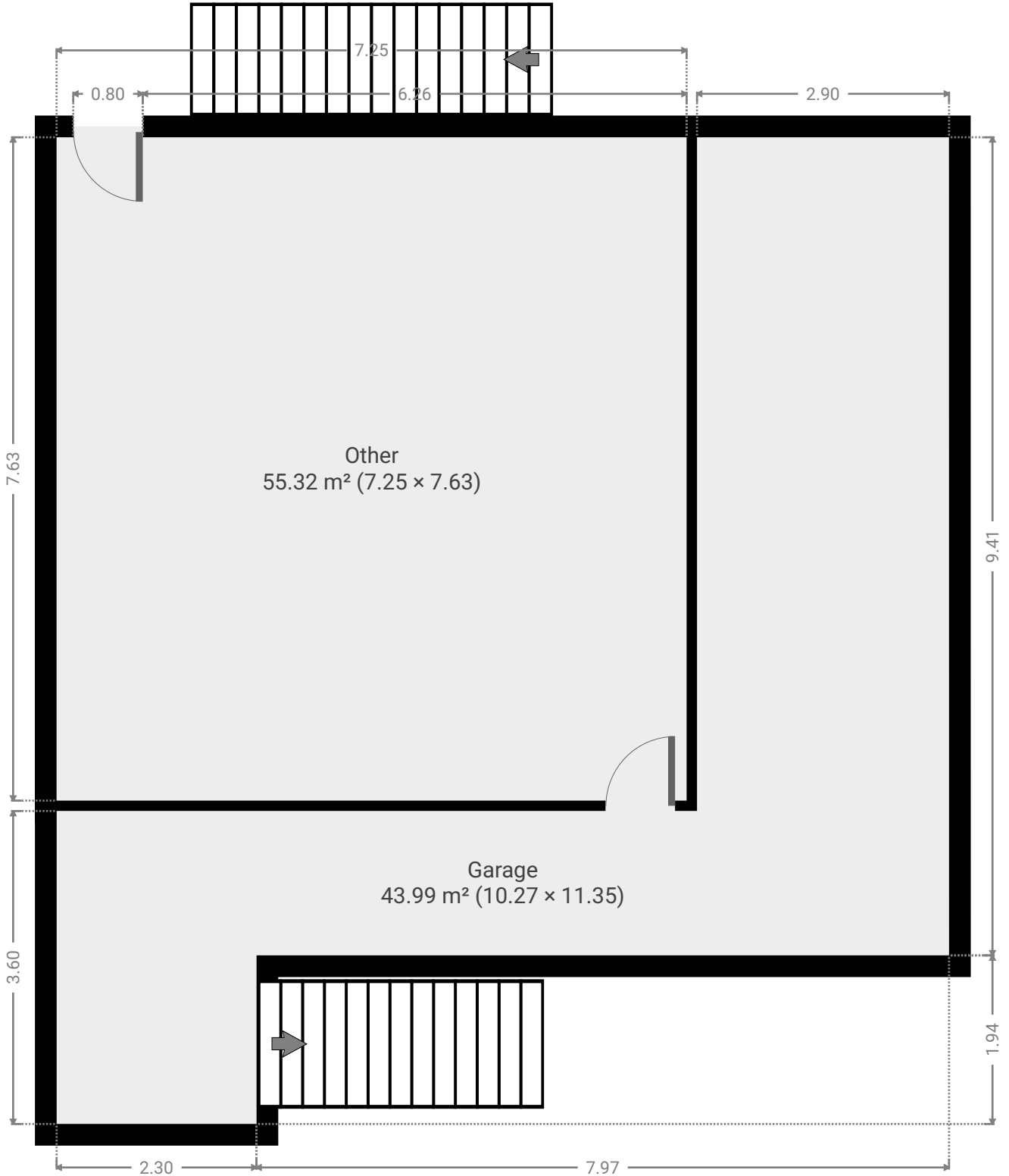

FLOORS: 2

▼ **Other**  
Ground Floor

WIDTH: 7.25 m • LENGTH: 7.63 m  
AREA: 55.32 m<sup>2</sup> • PERIMETER: 29.76 m

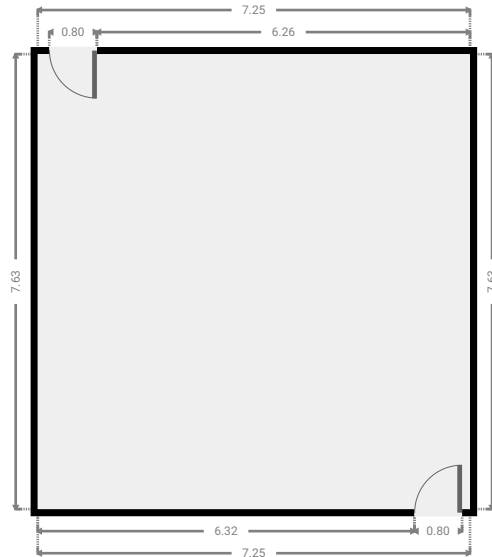
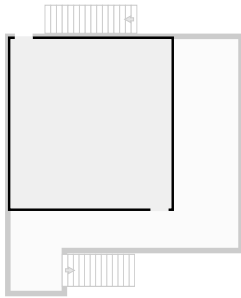

▼ **Garage**  
Ground Floor

WIDTH: 10.27 m • LENGTH: 11.35 m  
AREA: 43.99 m<sup>2</sup> • PERIMETER: 43.24 m

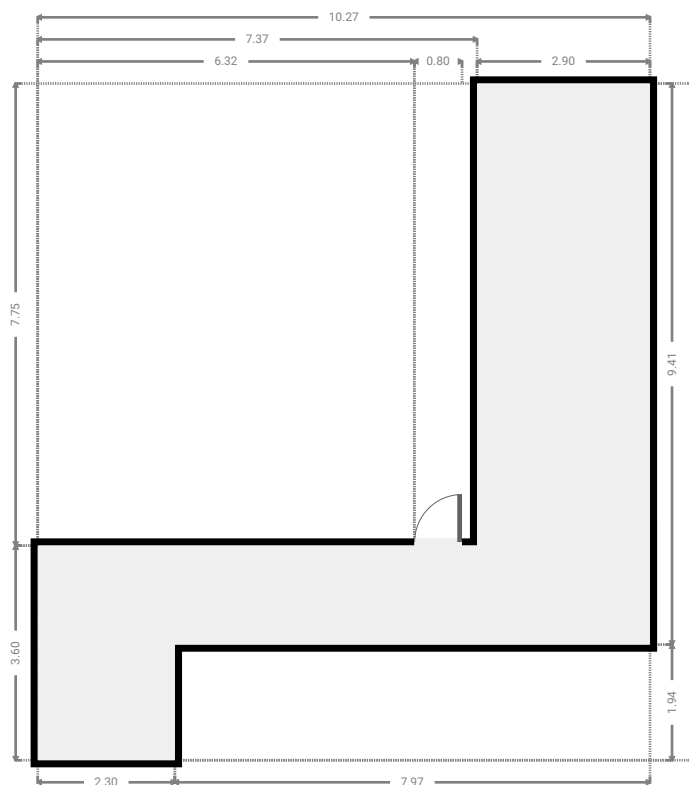
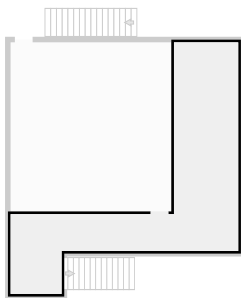

▼ 1st Floor

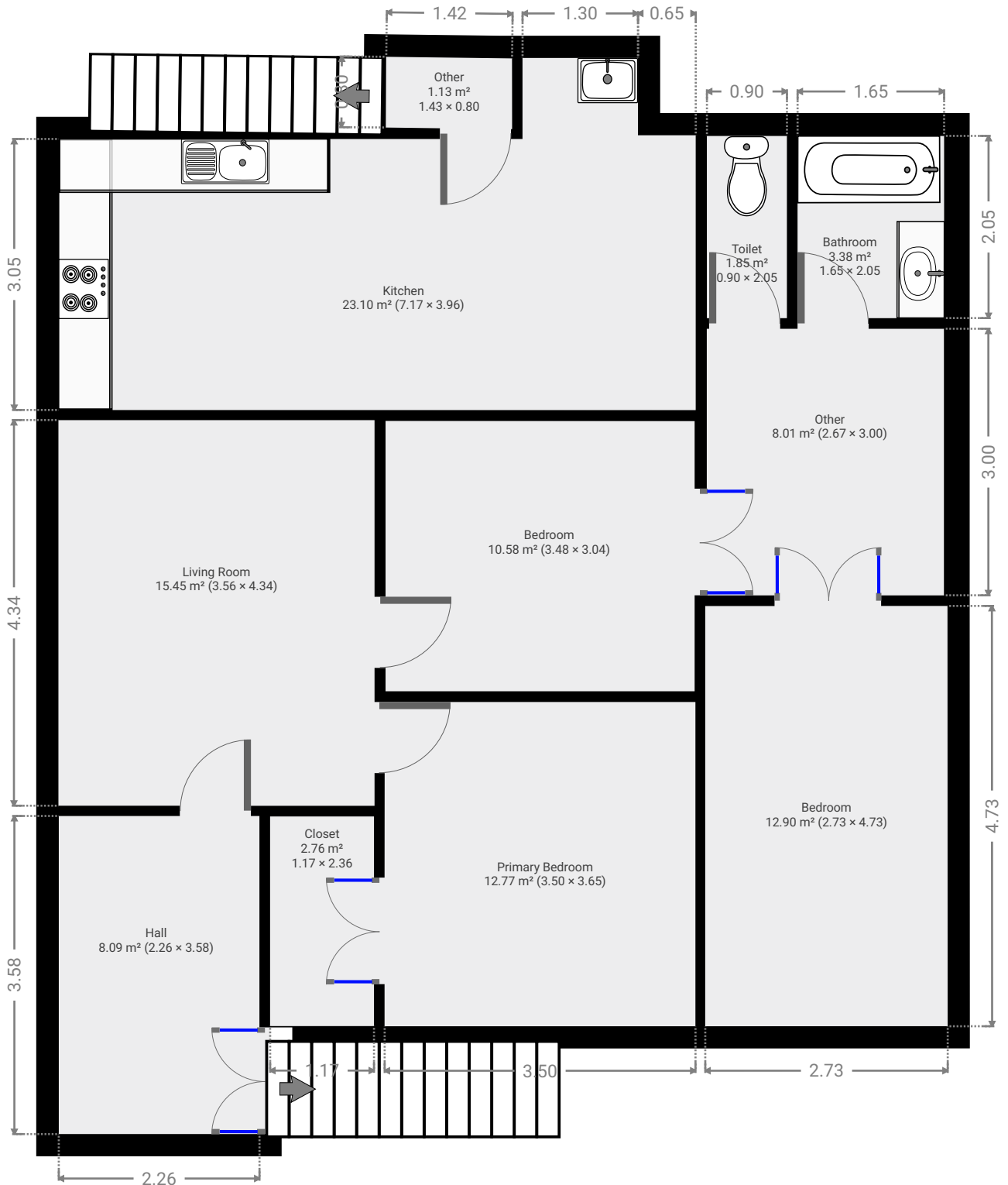

▼ **Hall**  
1st Floor

WIDTH: 2.26 m • LENGTH: 3.58 m  
AREA: 8.09 m<sup>2</sup> • PERIMETER: 11.68 m

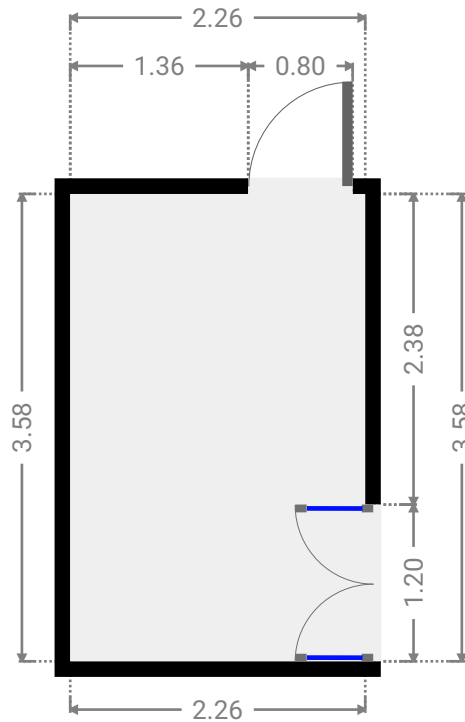
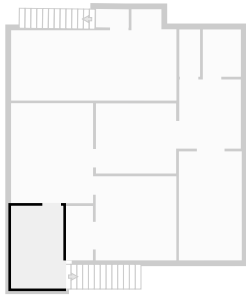

▼ **Living Room**  
1st Floor

WIDTH: 3.56 m • LENGTH: 4.34 m  
AREA: 15.45 m<sup>2</sup> • PERIMETER: 15.80 m

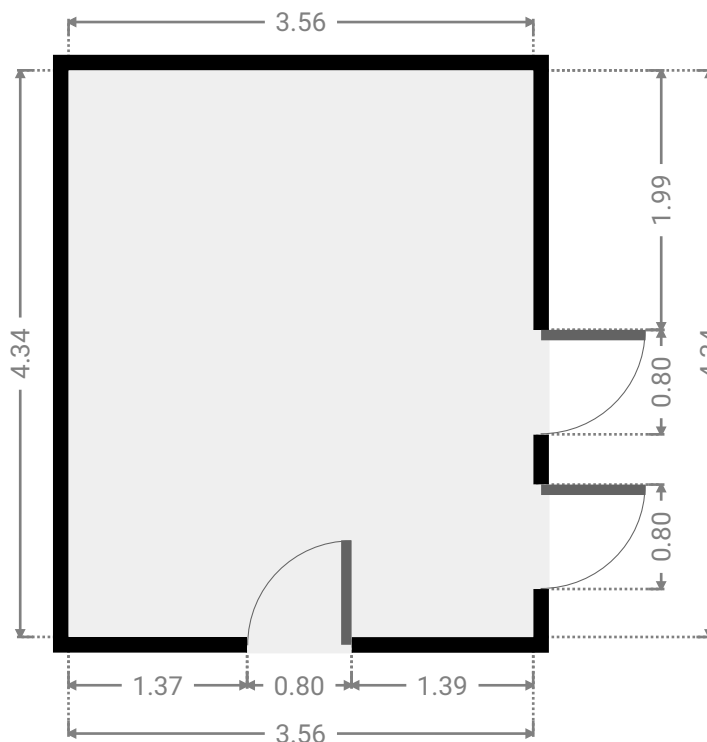
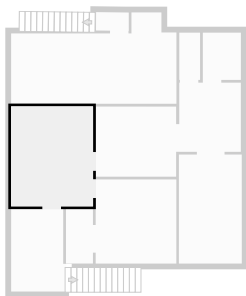

▼ Primary Bedroom  
1st Floor

WIDTH: 3.50 m • LENGTH: 3.65 m  
AREA: 12.77 m<sup>2</sup> • PERIMETER: 14.30 m

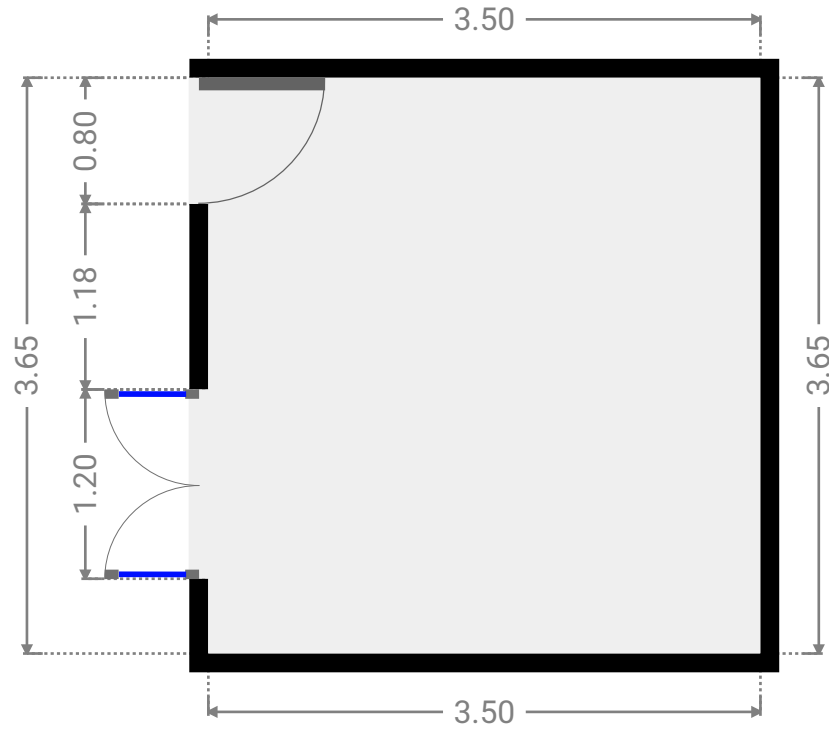
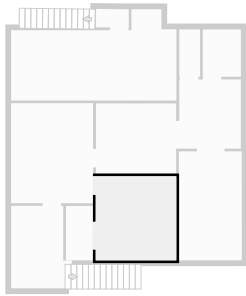

▼ Closet  
1st Floor

WIDTH: 1.17 m • LENGTH: 2.36 m  
AREA: 2.76 m<sup>2</sup> • PERIMETER: 7.06 m

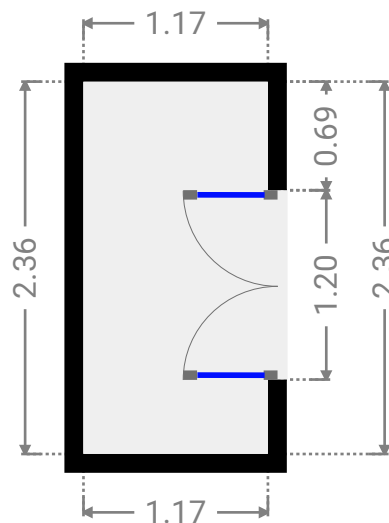
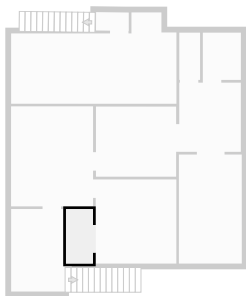

▼ **Bedroom**  
1st Floor

WIDTH: 3.48 m • LENGTH: 3.04 m  
AREA: 10.58 m<sup>2</sup> • PERIMETER: 13.04 m

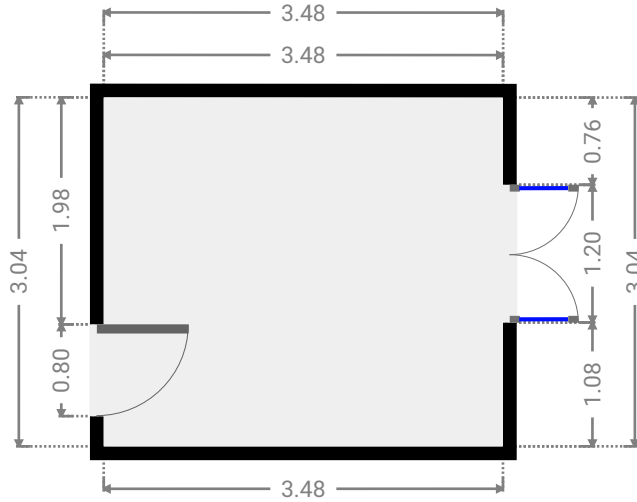
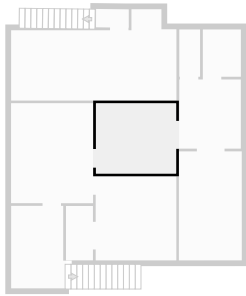

▼ **Bedroom**  
1st Floor

WIDTH: 2.73 m • LENGTH: 4.73 m  
AREA: 12.90 m<sup>2</sup> • PERIMETER: 14.92 m

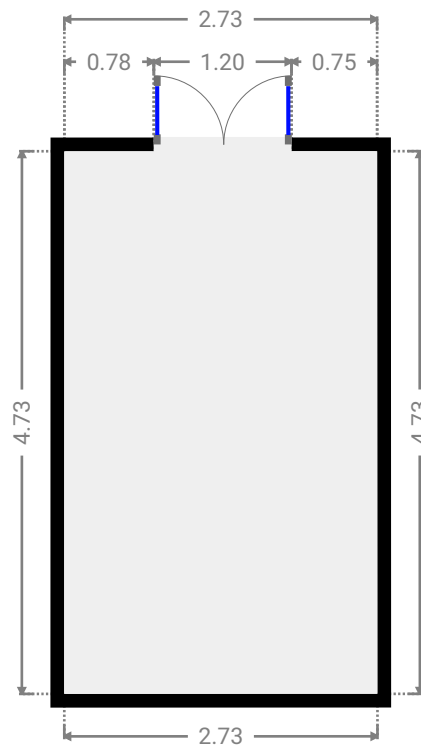
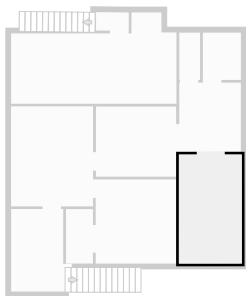

▼ Other  
1st Floor

WIDTH: 2.67 m • LENGTH: 3.00 m  
AREA: 8.01 m<sup>2</sup> • PERIMETER: 11.34 m

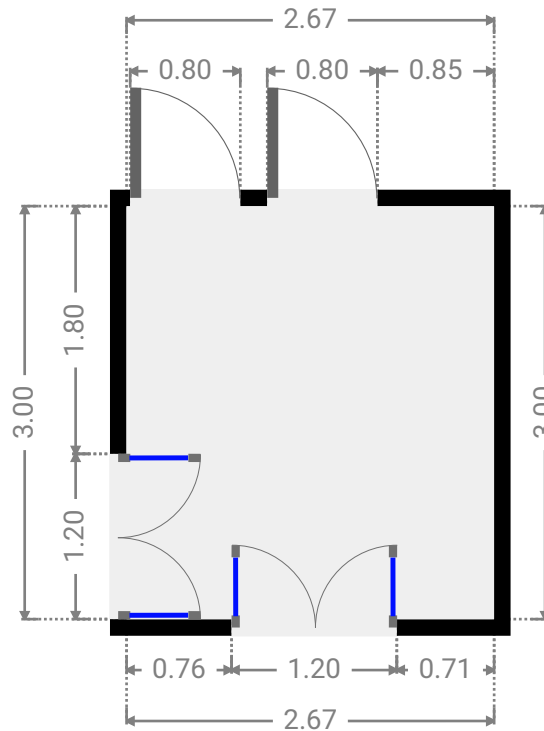
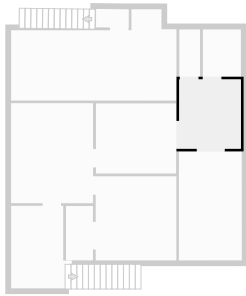

▼ Bathroom  
1st Floor

WIDTH: 1.65 m • LENGTH: 2.05 m  
AREA: 3.38 m<sup>2</sup> • PERIMETER: 7.40 m

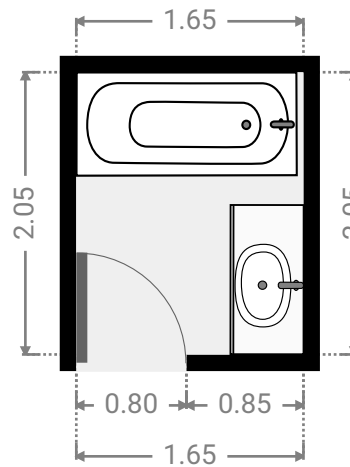
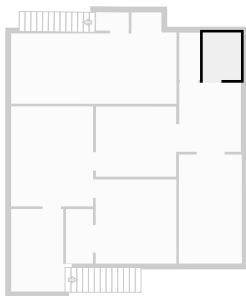



▼ Toilet  
1st Floor

WIDTH: 0.90 m • LENGTH: 2.05 m  
AREA: 1.85 m<sup>2</sup> • PERIMETER: 5.90 m

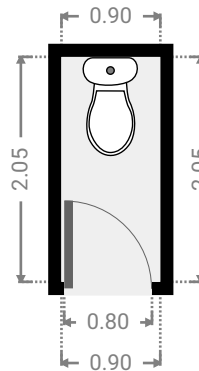
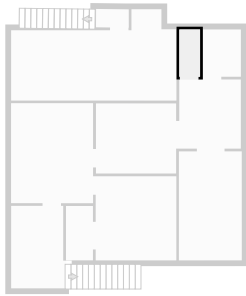

▼ Kitchen  
1st Floor

WIDTH: 7.17 m • LENGTH: 3.96 m  
AREA: 23.10 m<sup>2</sup> • PERIMETER: 22.27 m

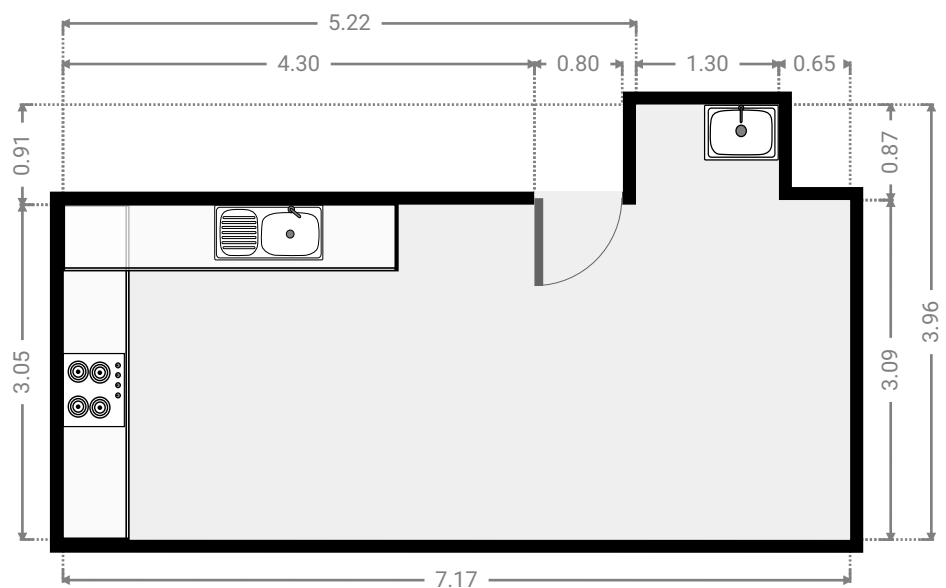
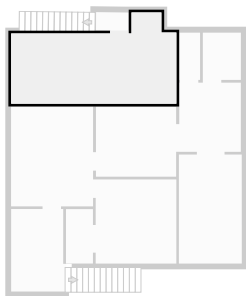

▼ Other  
1st Floor

WIDTH: 1.43 m • LENGTH: 0.80 m  
AREA: 1.13 m<sup>2</sup> • PERIMETER: 4.43 m

