

32 Rosewood Drive

Created on
2021-09-02

Floors
1

▼ Ground Floor

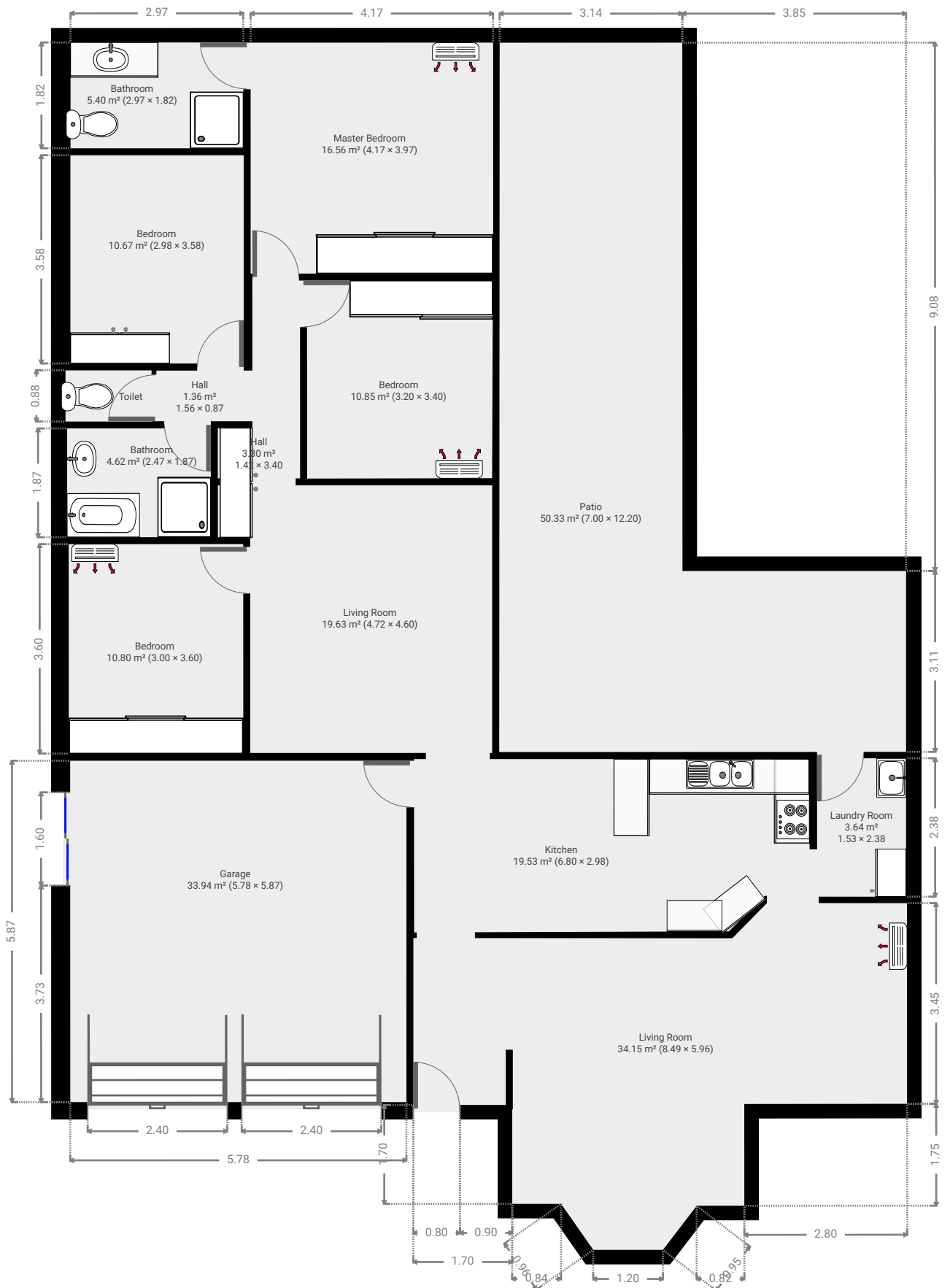

▼ Living Room
Ground Floor

WIDTH: 8.49 m • LENGTH: 5.96 m
AREA: 34.15 m² • PERIMETER: 27.79 m

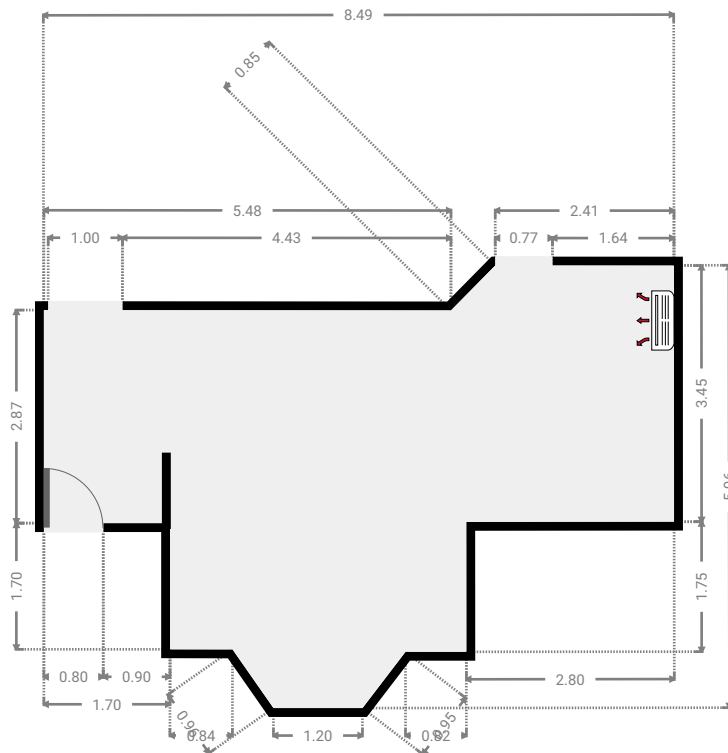
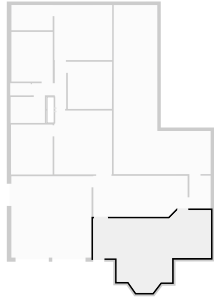

▼ Kitchen
Ground Floor

WIDTH: 6.80 m • LENGTH: 2.98 m
AREA: 19.53 m² • PERIMETER: 19.18 m

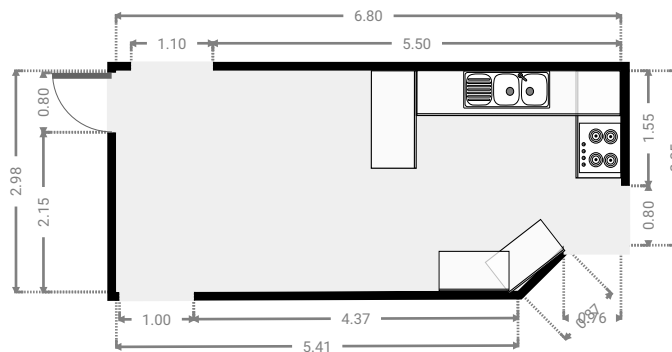
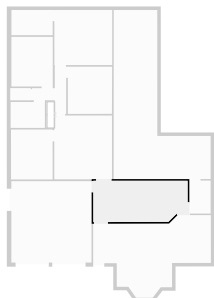

▼ Laundry Room
Ground Floor

WIDTH: 1.53 m • LENGTH: 2.38 m
AREA: 3.64 m² • PERIMETER: 7.82 m

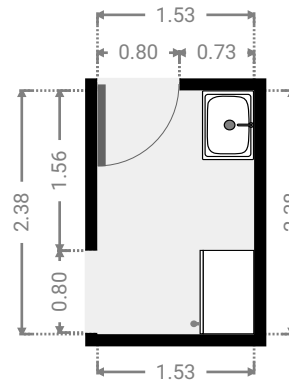
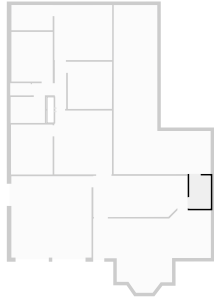

▼ Garage
Ground Floor

WIDTH: 5.78 m • LENGTH: 5.87 m
AREA: 33.94 m² • PERIMETER: 23.30 m

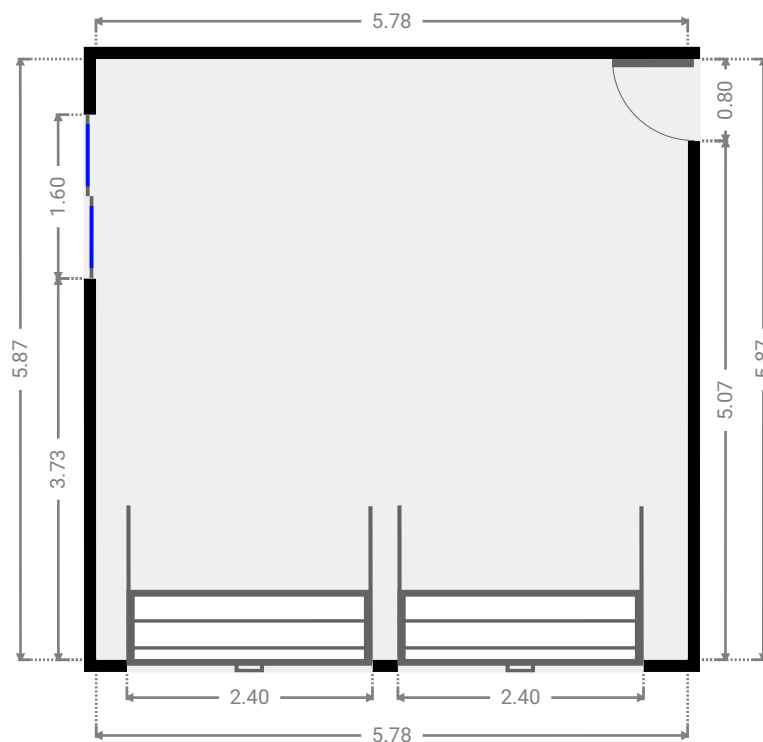
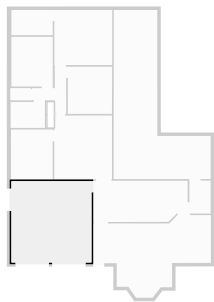

▼ Living Room
Ground Floor

WIDTH: 4.72 m • LENGTH: 4.60 m
AREA: 19.63 m² • PERIMETER: 18.63 m

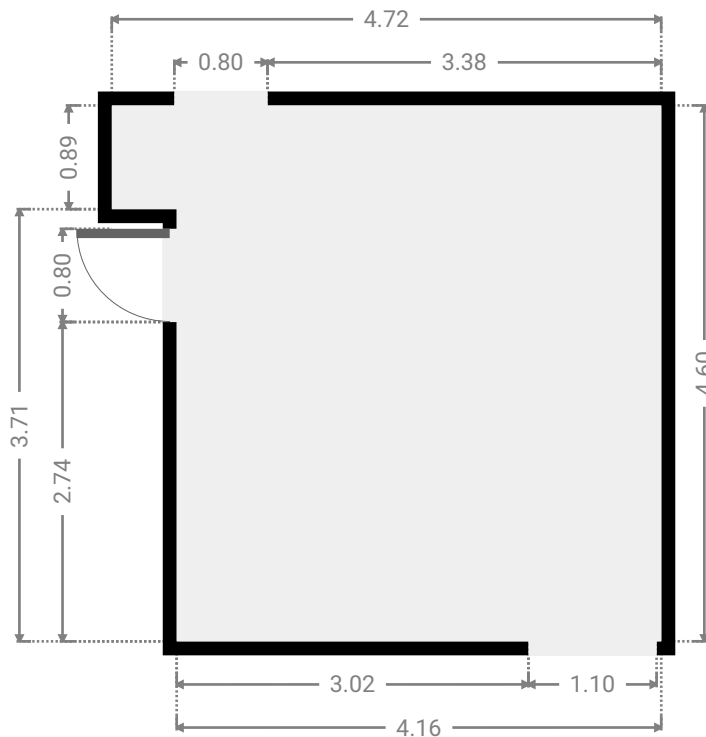
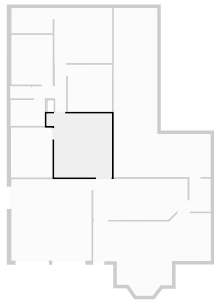

▼ Bedroom
Ground Floor

WIDTH: 3.00 m • LENGTH: 3.60 m
AREA: 10.80 m² • PERIMETER: 13.20 m

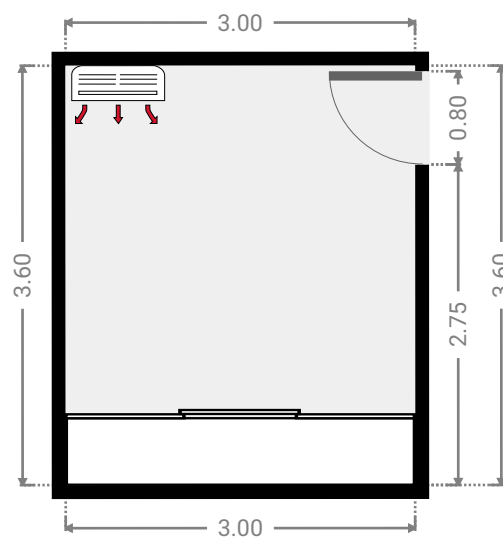
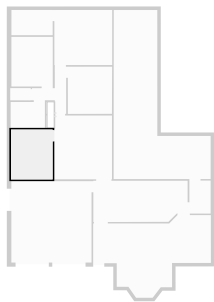

▼ **Hall**
Ground Floor

WIDTH: 1.42 m • LENGTH: 3.40 m
AREA: 3.30 m² • PERIMETER: 9.63 m

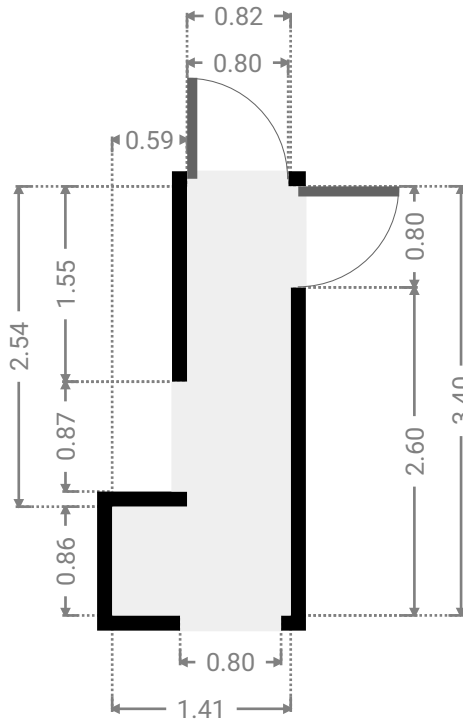
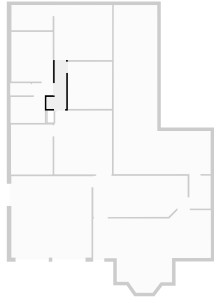

▼ **Bathroom**
Ground Floor

WIDTH: 2.47 m • LENGTH: 1.87 m
AREA: 4.62 m² • PERIMETER: 8.68 m

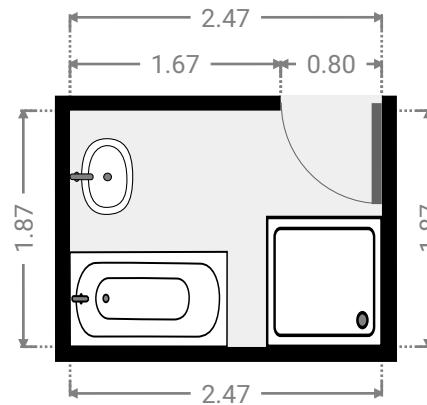
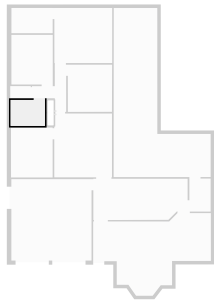

▼ **Hall**
Ground Floor

WIDTH: 1.56 m • LENGTH: 0.87 m
AREA: 1.36 m² • PERIMETER: 4.86 m

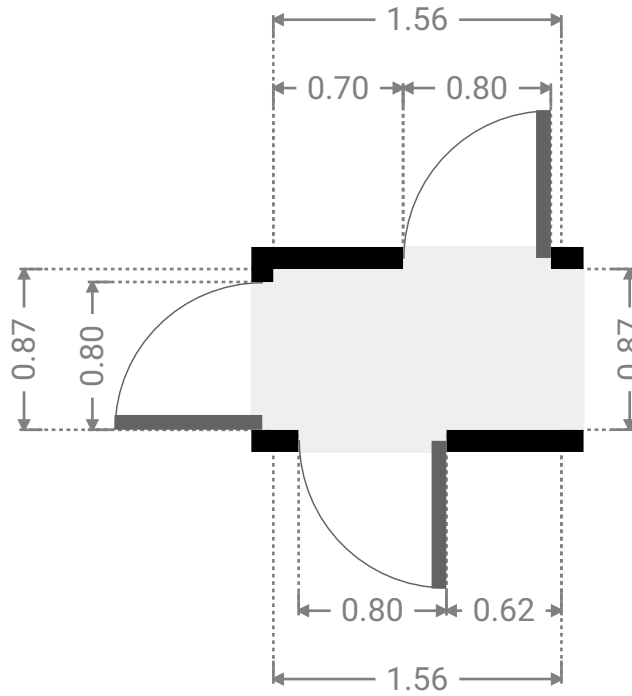
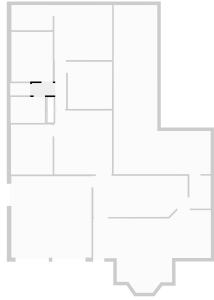

▼ **Toilet**
Ground Floor

WIDTH: 1.48 m • LENGTH: 0.88 m
AREA: 1.30 m² • PERIMETER: 4.72 m

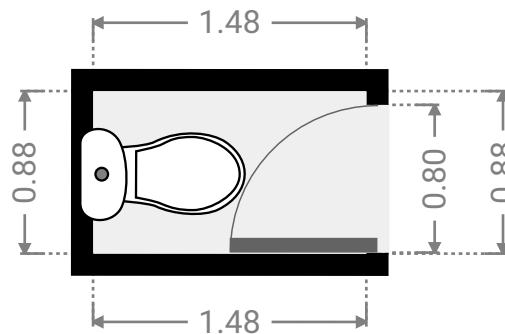
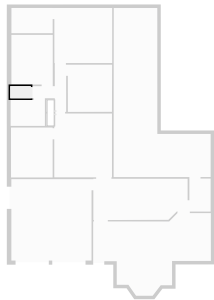

▼ **Bedroom**
Ground Floor

WIDTH: 2.98 m • LENGTH: 3.58 m
AREA: 10.67 m² • PERIMETER: 13.12 m

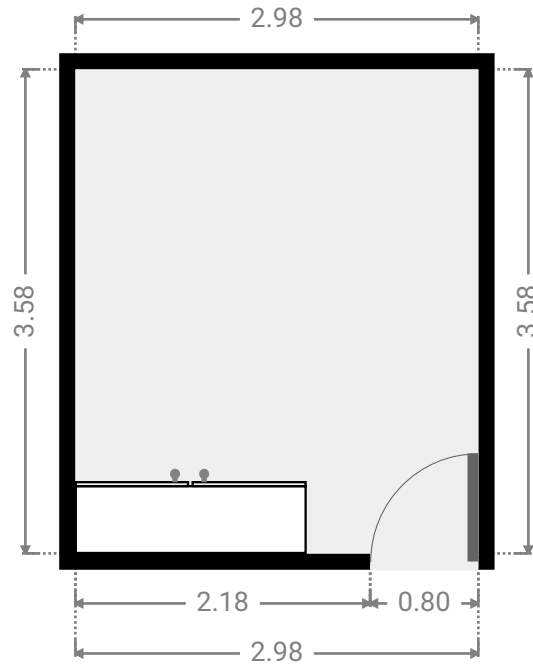
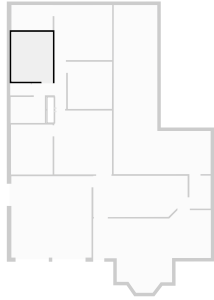

▼ **Master Bedroom**
Ground Floor

WIDTH: 4.17 m • LENGTH: 3.97 m
AREA: 16.56 m² • PERIMETER: 16.28 m

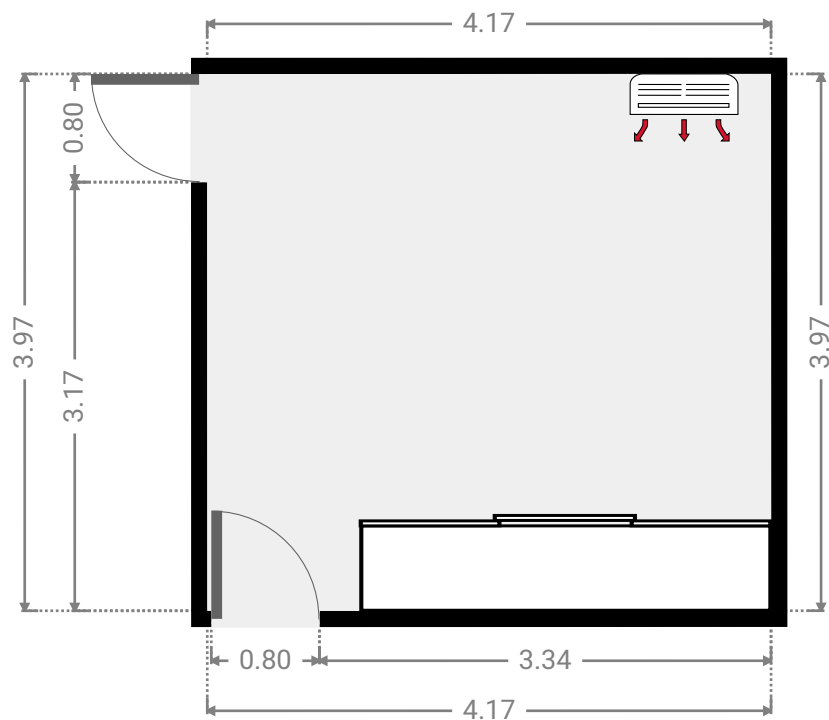
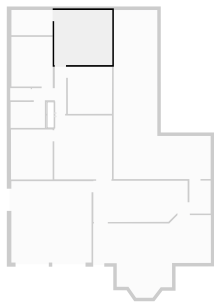

▼ Bathroom
Ground Floor

WIDTH: 2.97 m • LENGTH: 1.82 m
AREA: 5.40 m² • PERIMETER: 9.58 m

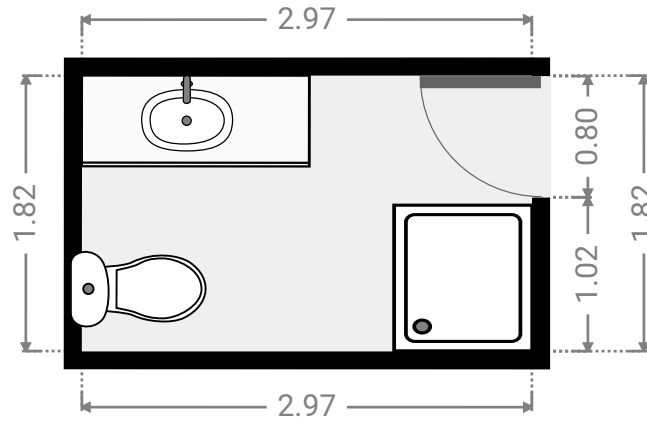
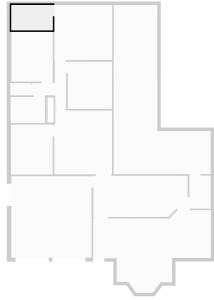

▼ Bedroom
Ground Floor

WIDTH: 3.20 m • LENGTH: 3.40 m
AREA: 10.85 m² • PERIMETER: 13.18 m

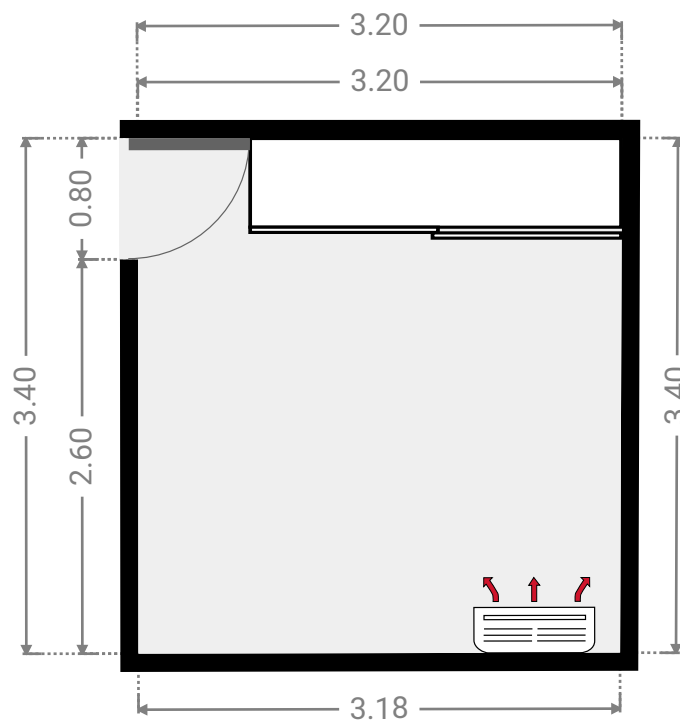
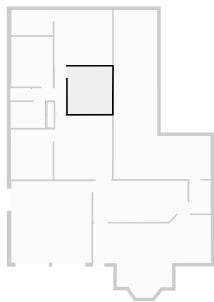

▼ Patio Ground Floor

WIDTH: 7.00 m • LENGTH: 12.20 m
AREA: 50.33 m² • PERIMETER: 38.37 m

