

# 319 Salamanca Street

Created on  
2021-03-16

Floors  
2

▼ Ground Floor

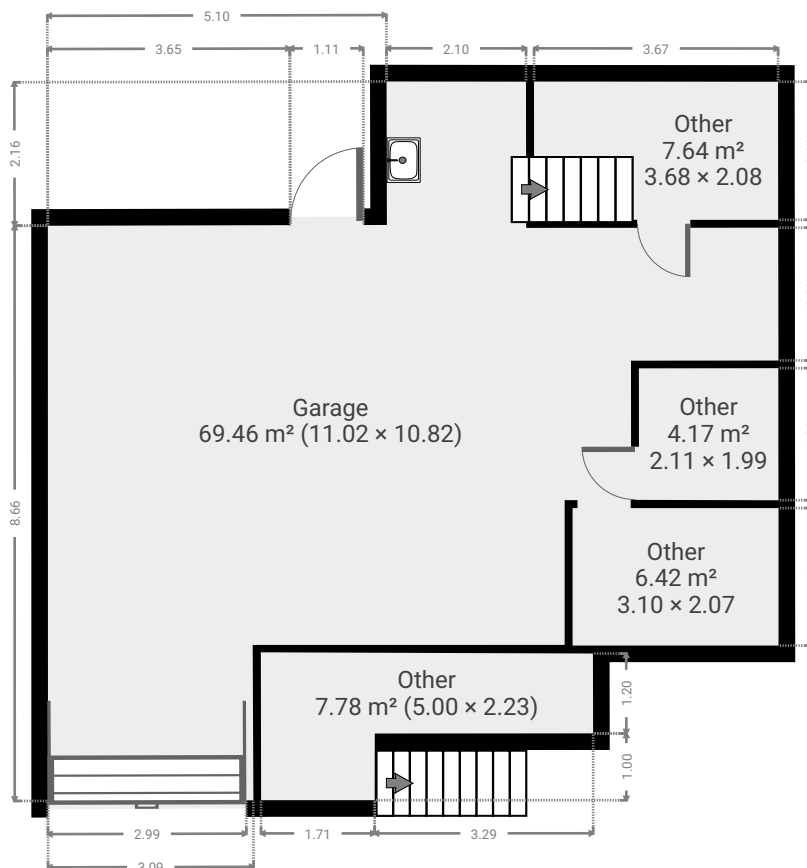
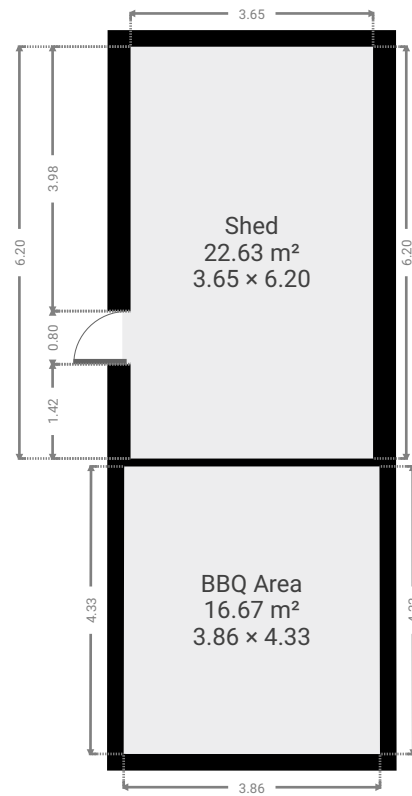

## ▼ Garage Ground Floor

WIDTH: 11.02 m • LENGTH: 10.82 m  
AREA: 69.46 m<sup>2</sup> • PERIMETER: 43.65 m

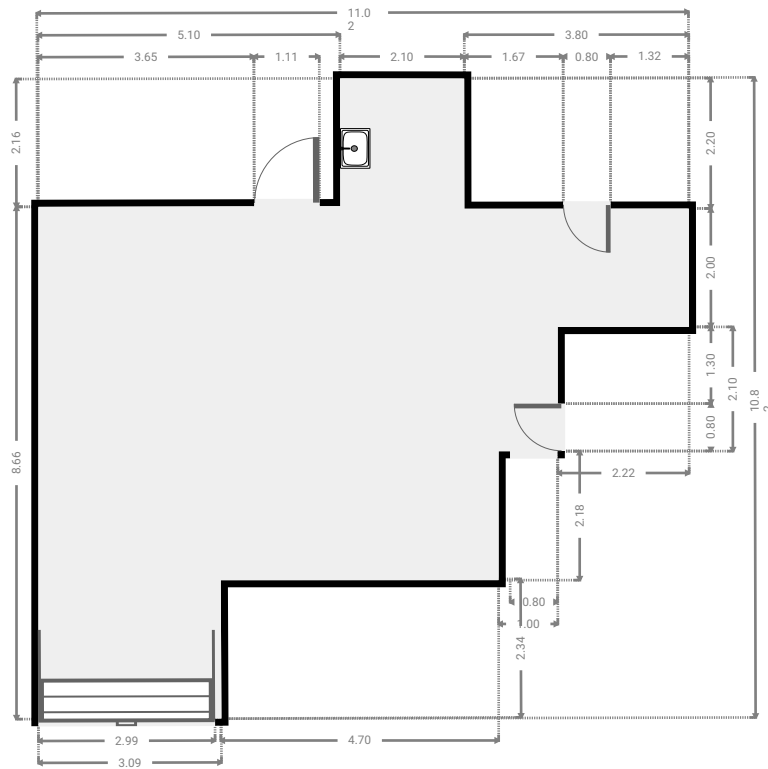
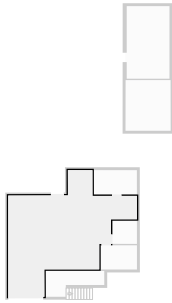

## ▼ Other Ground Floor

WIDTH: 3.10 m • LENGTH: 2.07 m  
AREA: 6.42 m<sup>2</sup> • PERIMETER: 10.34 m

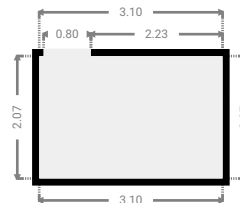
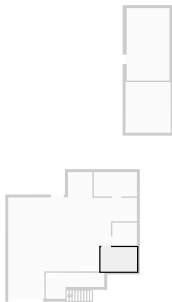

▼ Other  
Ground Floor

WIDTH: 2.11 m • LENGTH: 1.99 m  
AREA: 4.17 m<sup>2</sup> • PERIMETER: 8.17 m

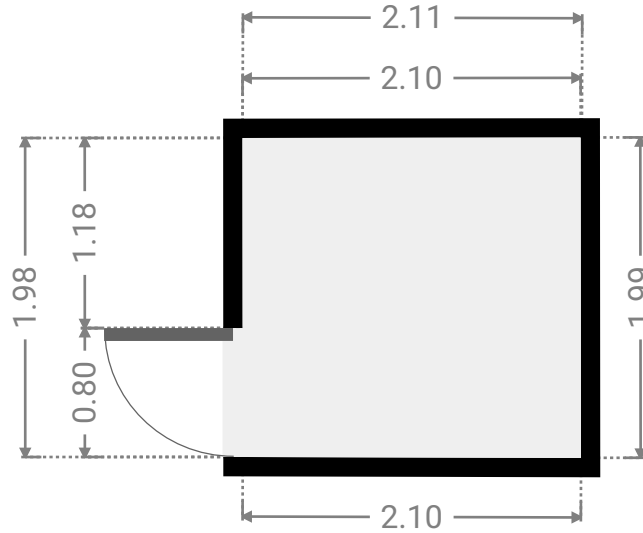
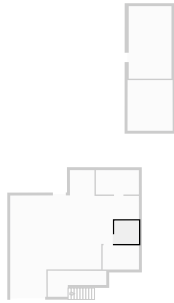

▼ Other  
Ground Floor

WIDTH: 3.68 m • LENGTH: 2.08 m  
AREA: 7.64 m<sup>2</sup> • PERIMETER: 11.51 m

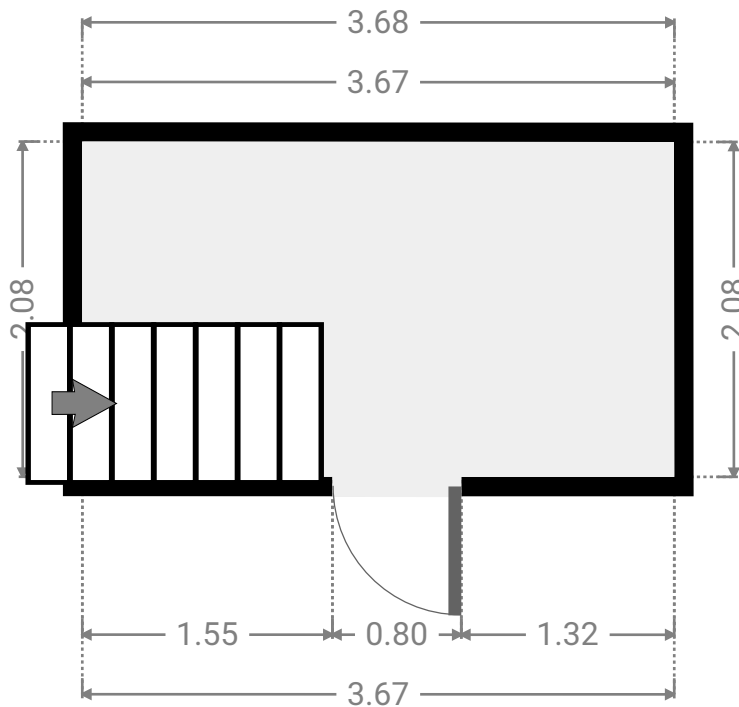
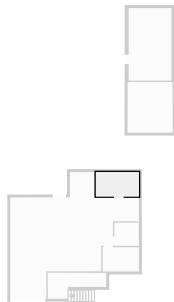

▼ **BBQ Area**  
Ground Floor

WIDTH: 3.86 m • LENGTH: 4.33 m  
AREA: 16.67 m<sup>2</sup> • PERIMETER: 16.36 m

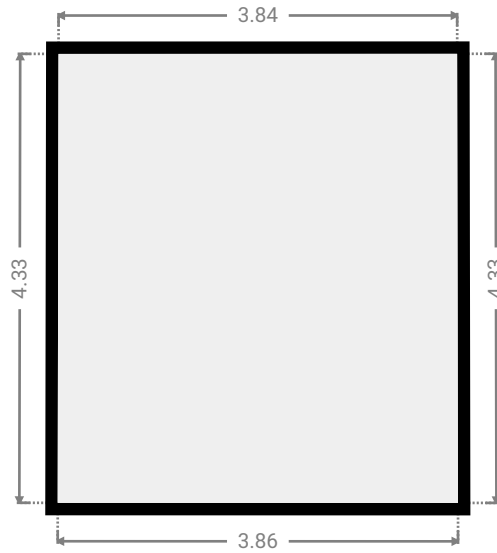
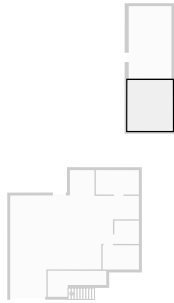

▼ **Shed**  
Ground Floor

WIDTH: 3.65 m • LENGTH: 6.20 m  
AREA: 22.63 m<sup>2</sup> • PERIMETER: 19.70 m

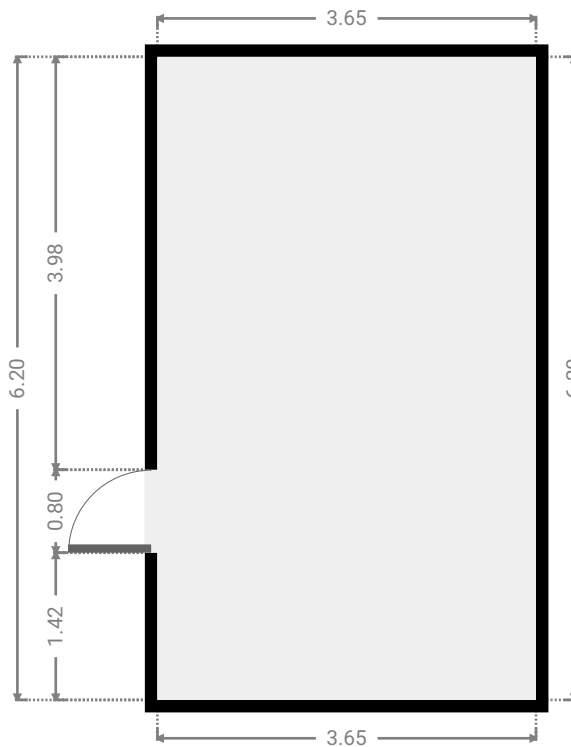
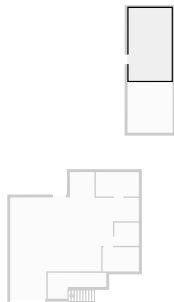

▼ Other  
Ground Floor

WIDTH: 5.00 m • LENGTH: 2.23 m  
AREA: 7.78 m<sup>2</sup> • PERIMETER: 14.43 m

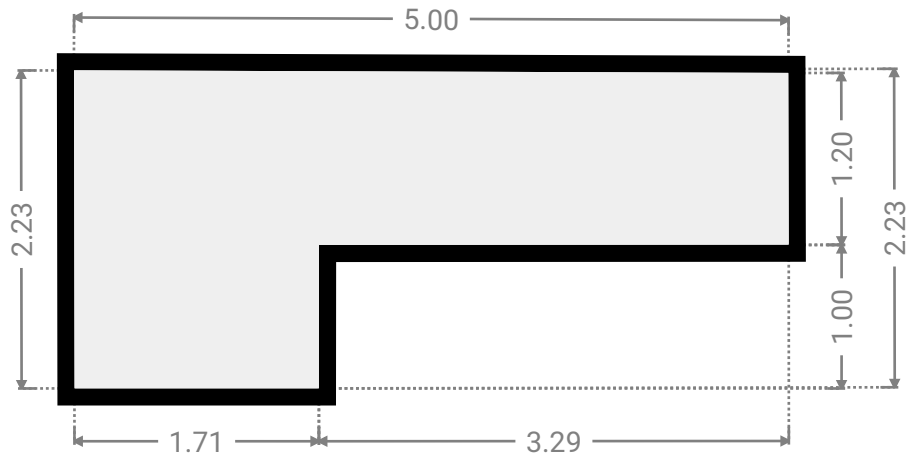
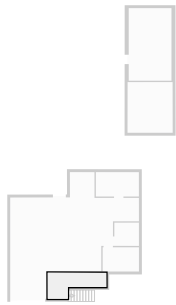

▼ 1st Floor

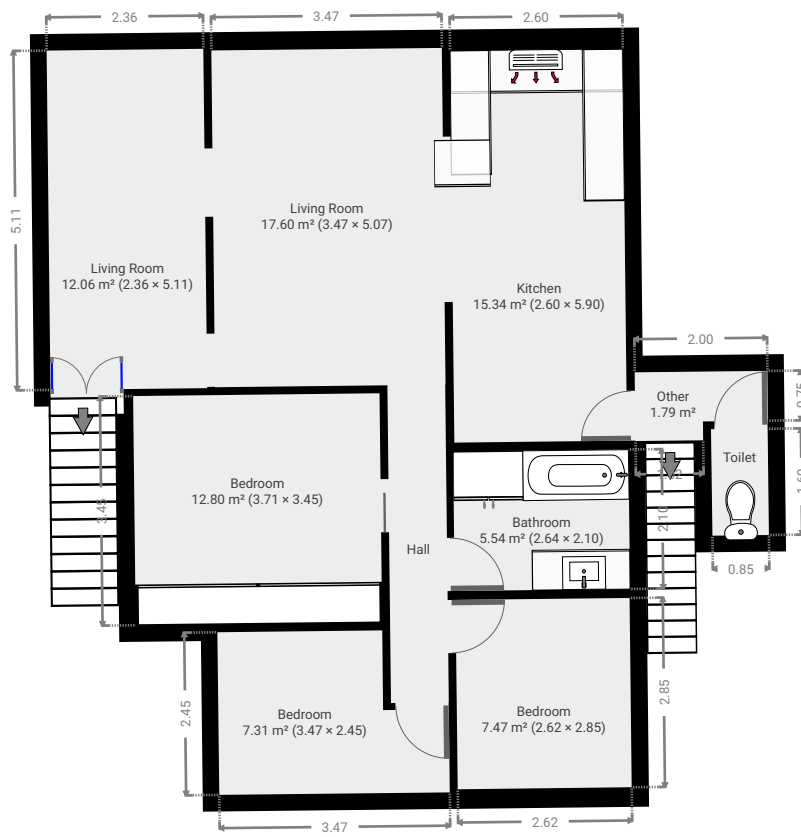

▼ Living Room  
1st Floor

WIDTH: 5.11 m • LENGTH: 2.36 m  
AREA: 12.06 m<sup>2</sup> • PERIMETER: 14.94 m

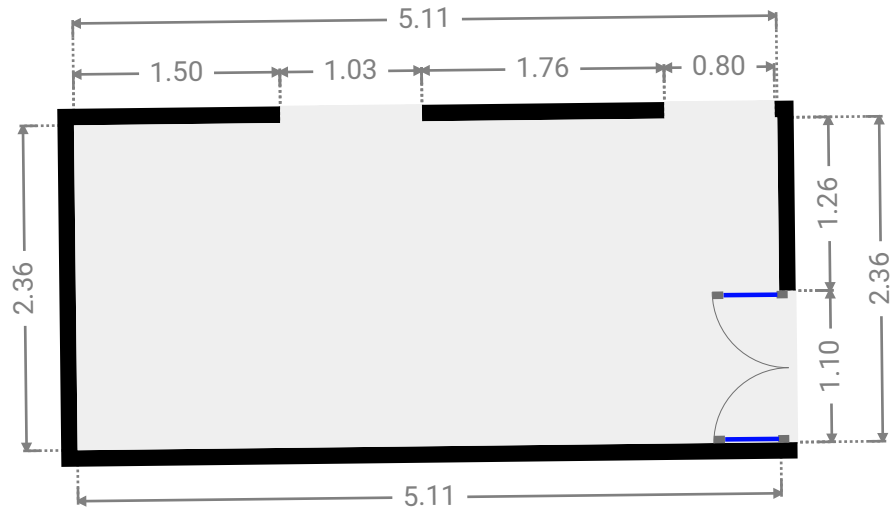
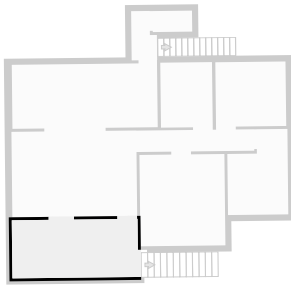

▼ Living Room  
1st Floor

WIDTH: 5.07 m • LENGTH: 3.47 m  
AREA: 17.60 m<sup>2</sup> • PERIMETER: 17.08 m

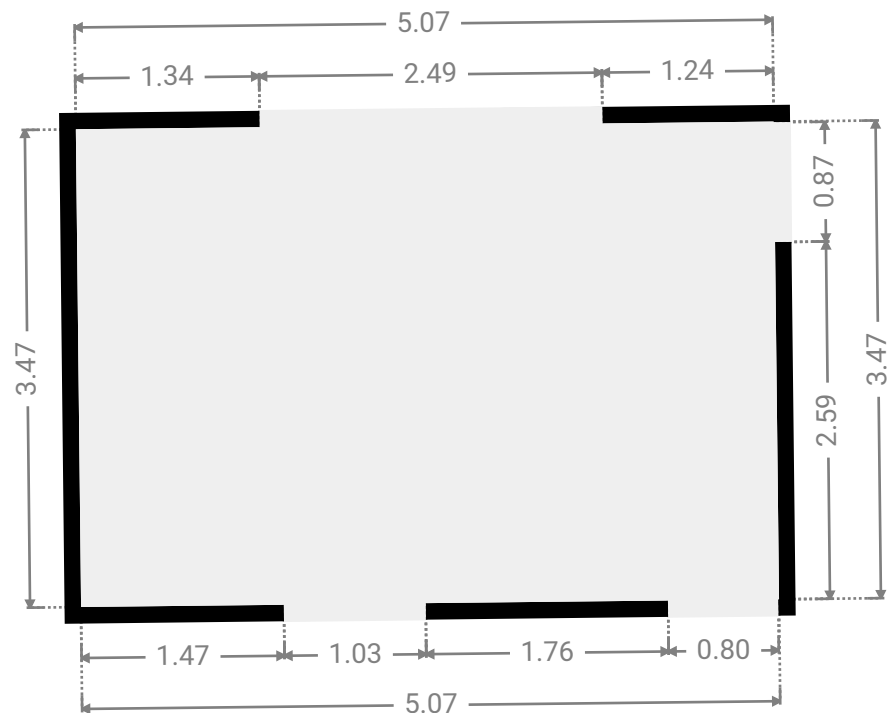
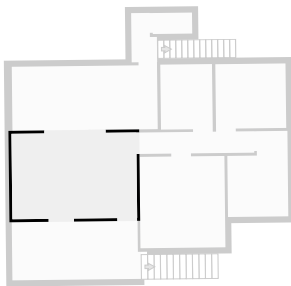



▼ **Kitchen**  
1st Floor

WIDTH: 5.90 m • LENGTH: 2.60 m  
AREA: 15.34 m<sup>2</sup> • PERIMETER: 17.00 m

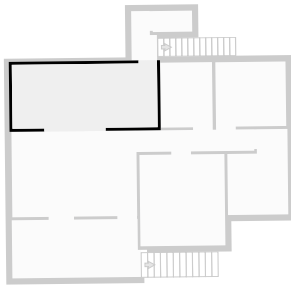

▼ **Hall**  
1st Floor

WIDTH: 4.68 m • LENGTH: 0.87 m  
AREA: 4.07 m<sup>2</sup> • PERIMETER: 11.10 m

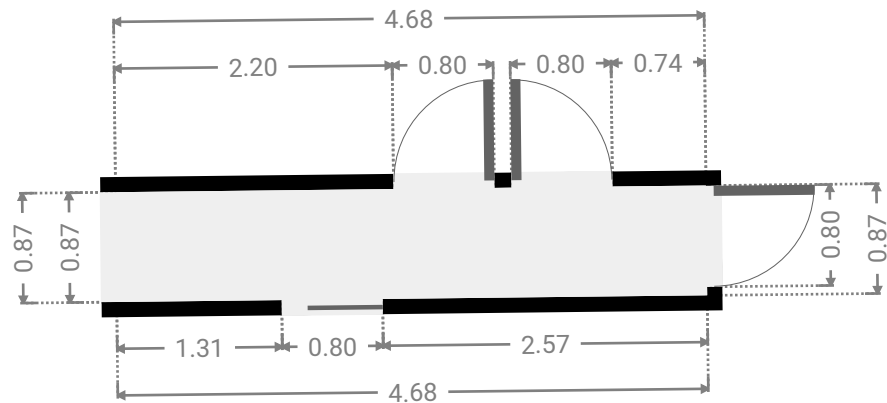
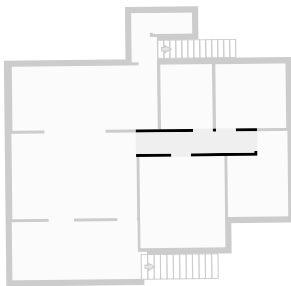

▼ **Bathroom**  
1st Floor

WIDTH: 2.10 m • LENGTH: 2.64 m  
AREA: 5.54 m<sup>2</sup> • PERIMETER: 9.48 m

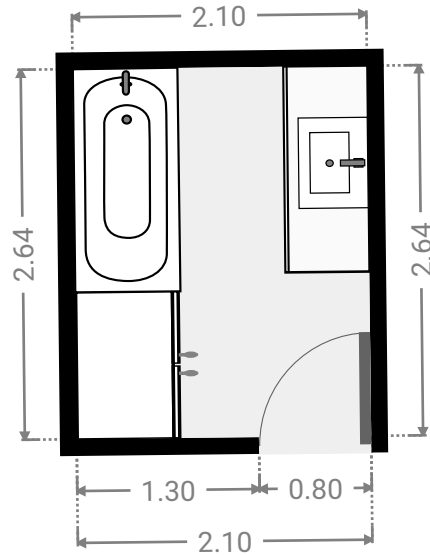
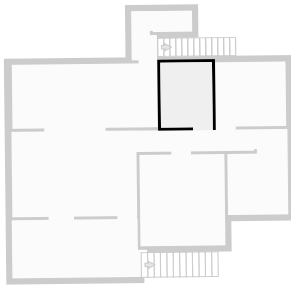

▼ **Bedroom**  
1st Floor

WIDTH: 3.45 m • LENGTH: 3.71 m  
AREA: 12.80 m<sup>2</sup> • PERIMETER: 14.32 m

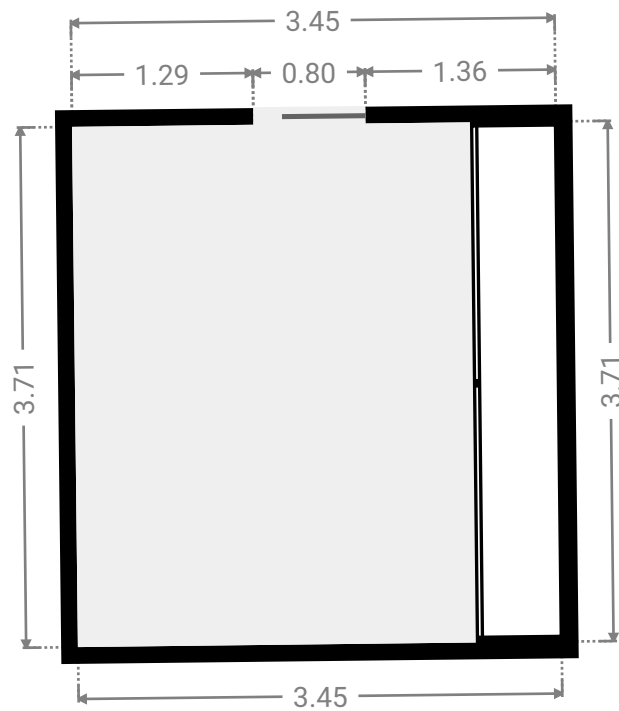
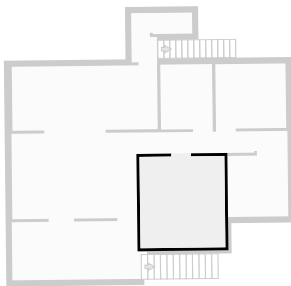

▼ **Bedroom**  
1st Floor

WIDTH: 2.45 m • LENGTH: 3.47 m  
AREA: 7.31 m<sup>2</sup> • PERIMETER: 11.84 m

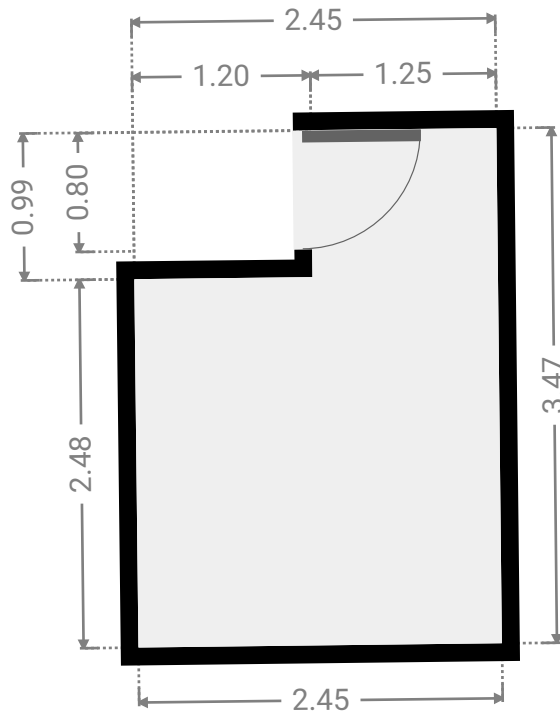
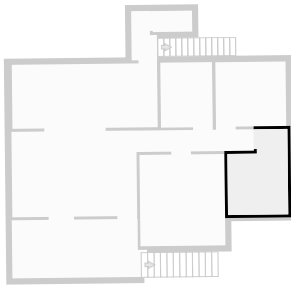

▼ **Bedroom**  
1st Floor

WIDTH: 2.85 m • LENGTH: 2.62 m  
AREA: 7.47 m<sup>2</sup> • PERIMETER: 10.94 m

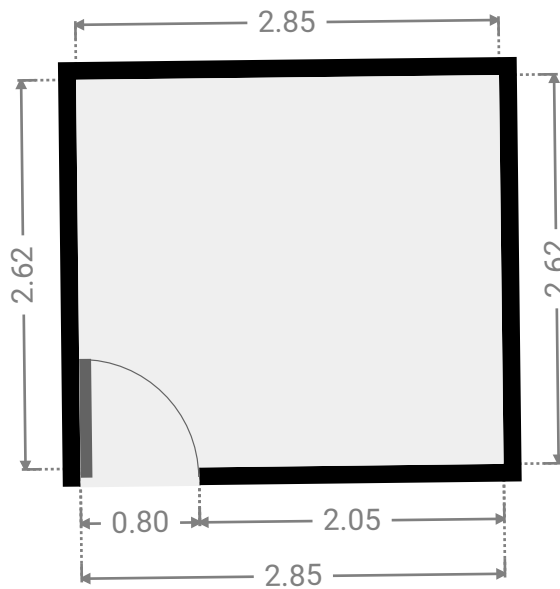
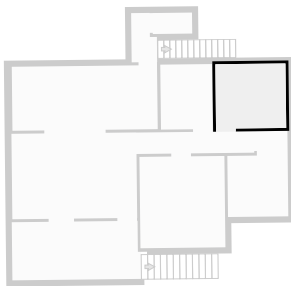

▼ Other  
1st Floor

WIDTH: 1.03 m • LENGTH: 2.00 m  
AREA: 1.79 m<sup>2</sup> • PERIMETER: 6.06 m

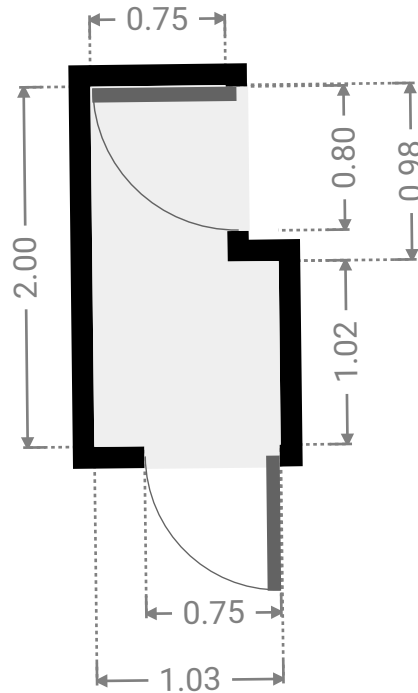
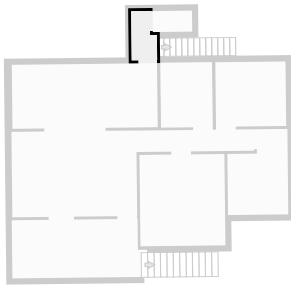

▼ Toilet  
1st Floor

WIDTH: 1.60 m • LENGTH: 0.85 m  
AREA: 1.36 m<sup>2</sup> • PERIMETER: 4.91 m

