

312 Shields Avenue

SUBMITTED BY

Ray White Rockhampton Casey
stockers@cqoz.com

CREATED ON

2022-10-04

Floors

2

▼ Ground Floor



▼ **Garage**
Ground Floor

WIDTH: 11.97 m • LENGTH: 6.15 m
AREA: 69.86 m² • PERIMETER: 42.22 m

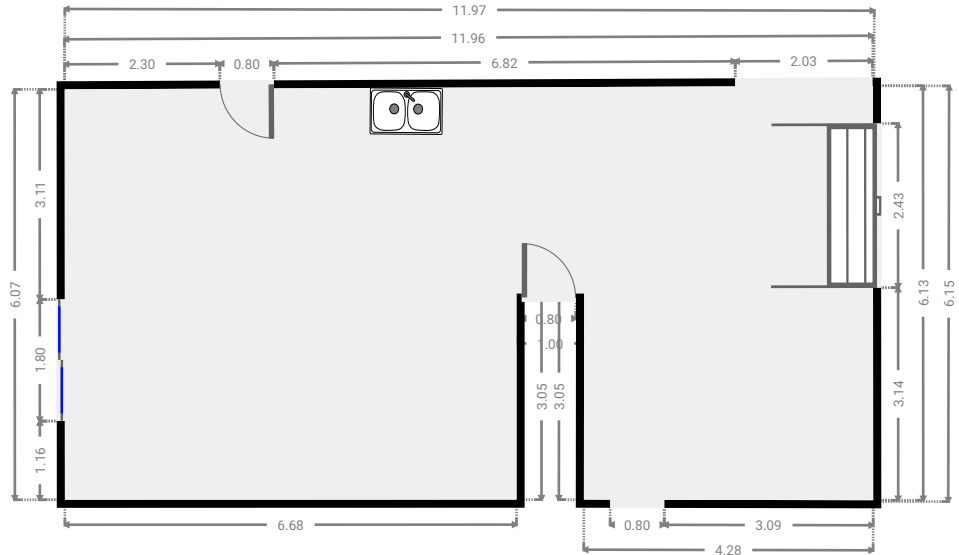
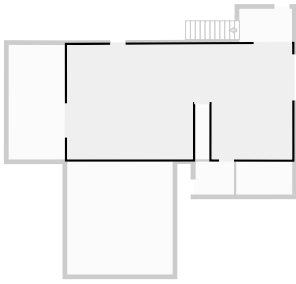

▼ **Garage**
Ground Floor

WIDTH: 5.60 m • LENGTH: 6.00 m
AREA: 33.60 m² • PERIMETER: 23.20 m

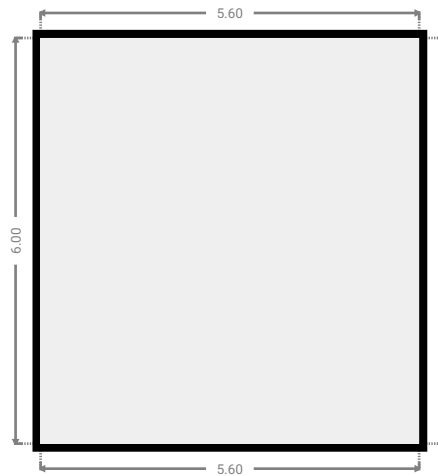
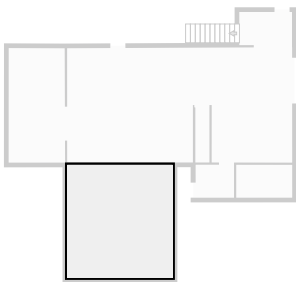

▼ **Hall**
Ground Floor

WIDTH: 2.80 m • LENGTH: 1.76 m
AREA: 4.93 m² • PERIMETER: 9.12 m

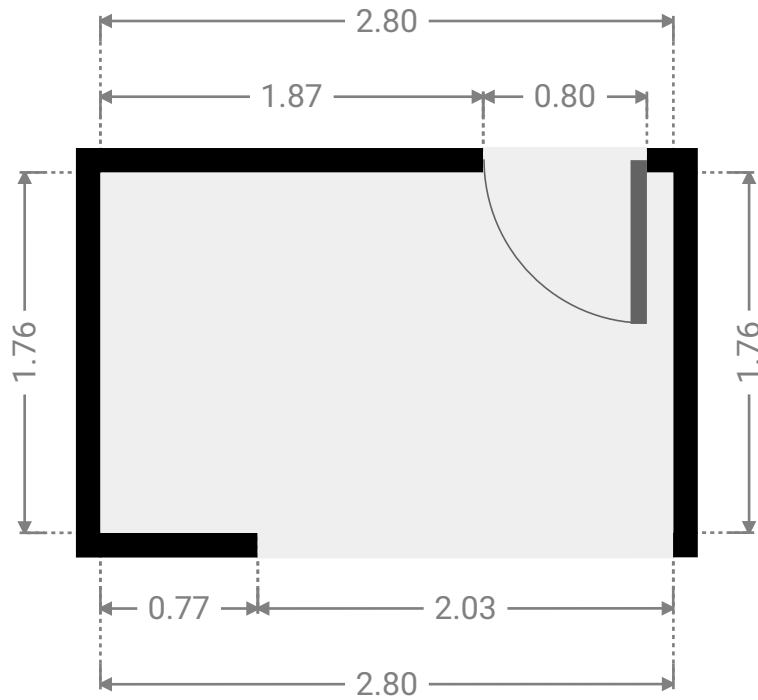
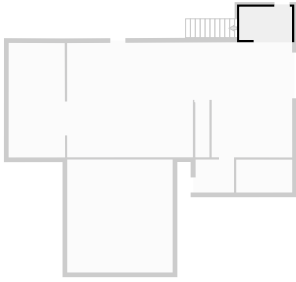

▼ **Hallway**
Ground Floor

WIDTH: 2.04 m • LENGTH: 1.75 m
AREA: 3.57 m² • PERIMETER: 7.58 m

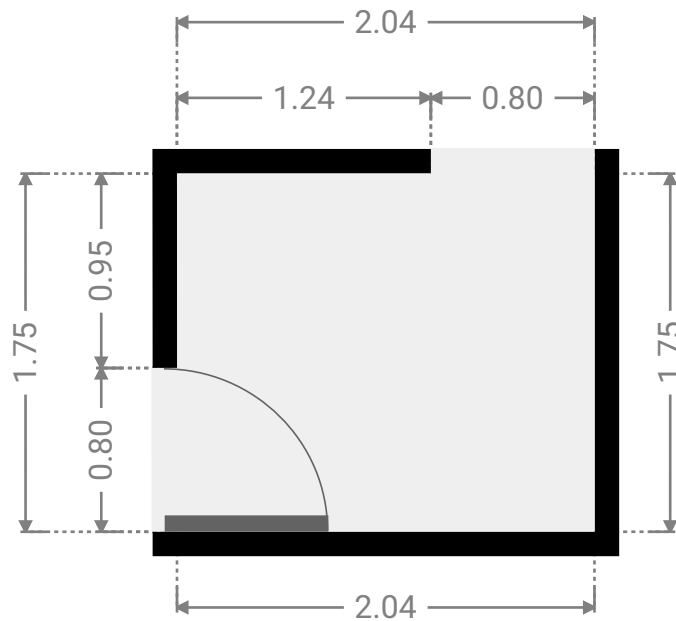
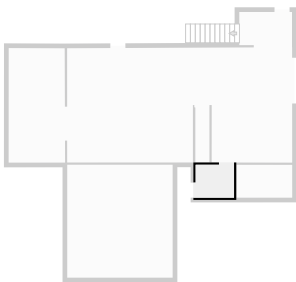

▼ Other
Ground Floor

WIDTH: 2.97 m • LENGTH: 1.75 m
AREA: 5.19 m² • PERIMETER: 9.44 m

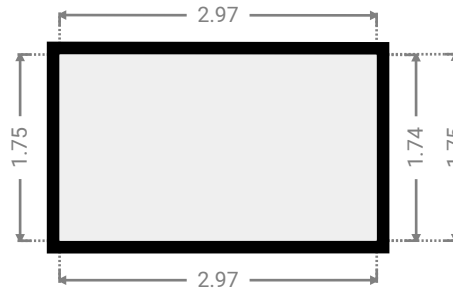
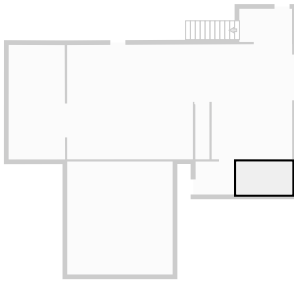

▼ Other
Ground Floor

WIDTH: 3.00 m • LENGTH: 6.10 m
AREA: 18.16 m² • PERIMETER: 18.13 m

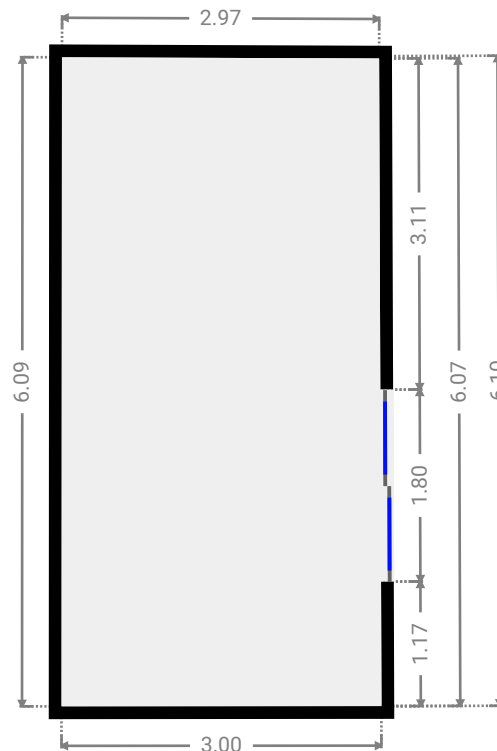
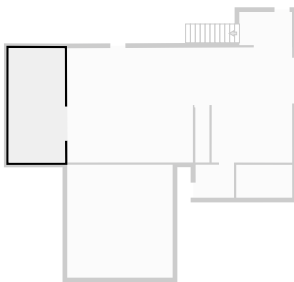

▼ Toilet
Ground Floor

WIDTH: 0.75 m • LENGTH: 2.93 m
AREA: 2.19 m² • PERIMETER: 7.36 m

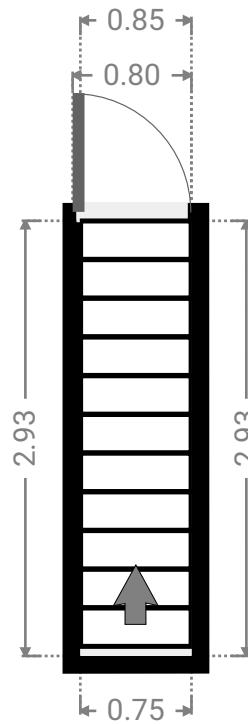
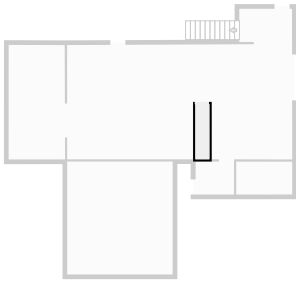

▼ 1st Floor

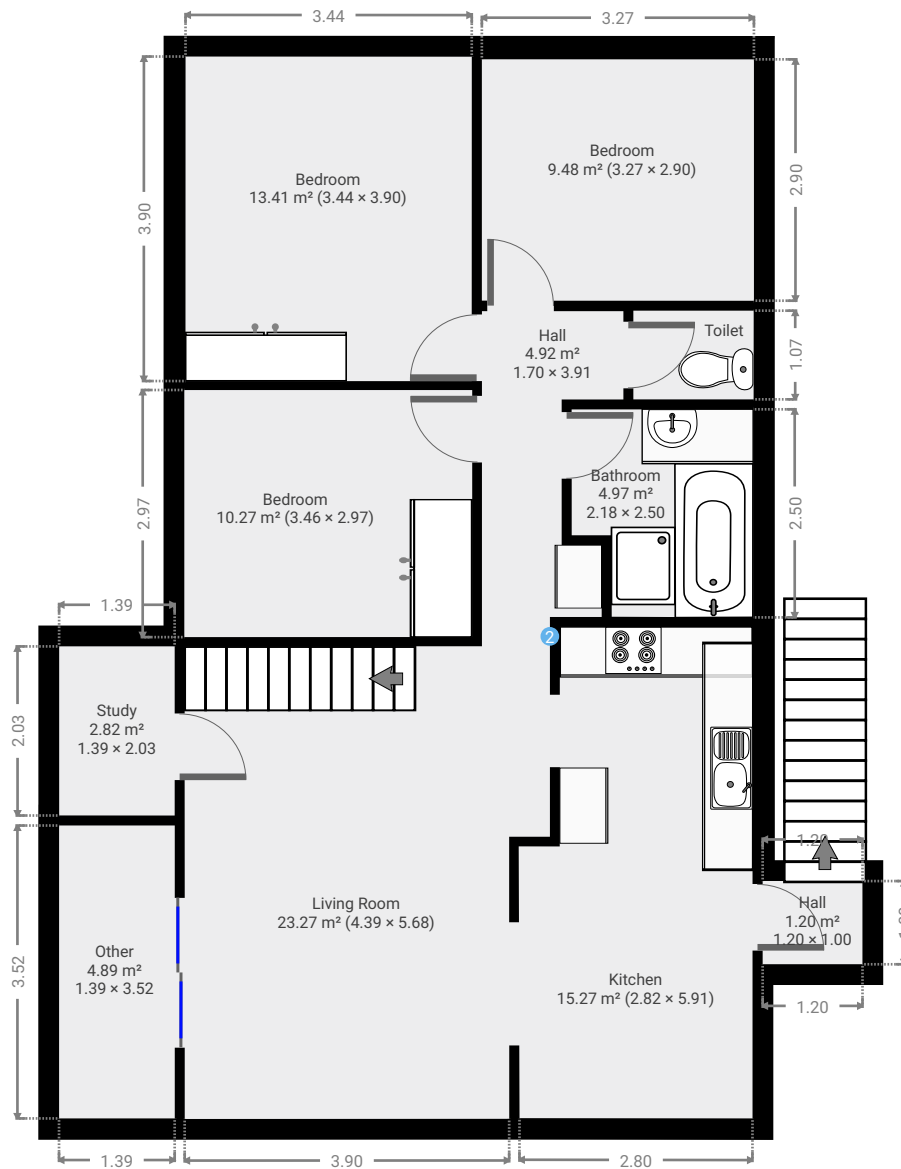

▼ **Bathroom**
1st Floor

WIDTH: 2.50 m • LENGTH: 2.18 m
AREA: 4.97 m² • PERIMETER: 9.35 m

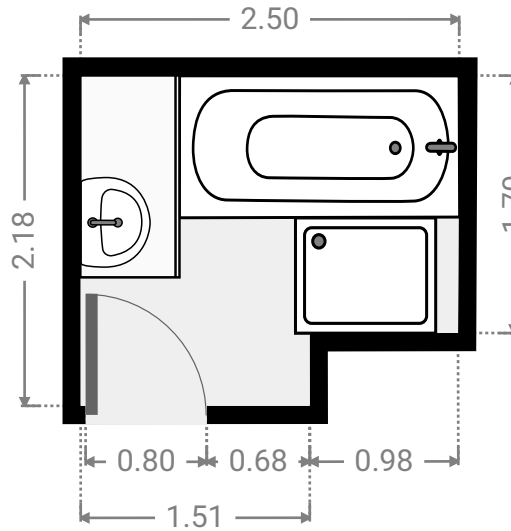
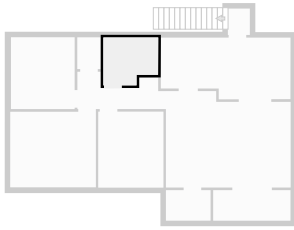

▼ **Bedroom**
1st Floor

WIDTH: 2.97 m • LENGTH: 3.46 m
AREA: 10.27 m² • PERIMETER: 12.86 m

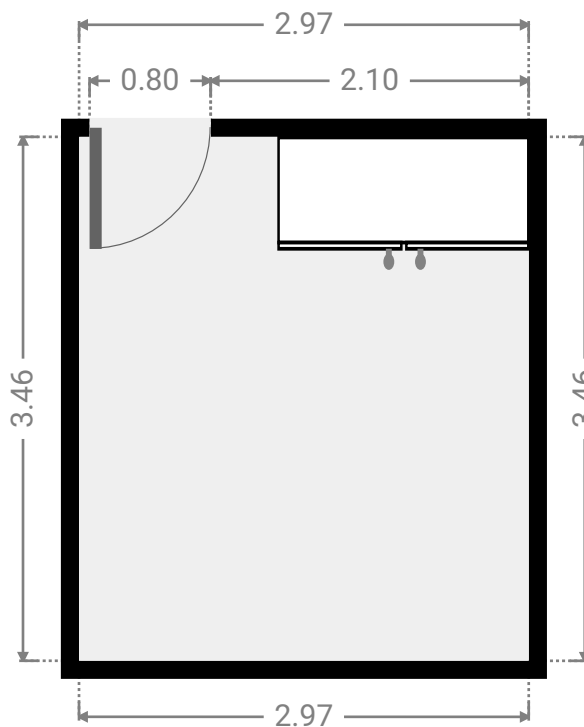
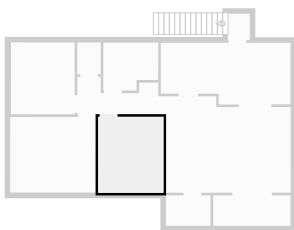

▼ **Bedroom**
1st Floor

WIDTH: 3.90 m • LENGTH: 3.44 m
AREA: 13.41 m² • PERIMETER: 14.68 m

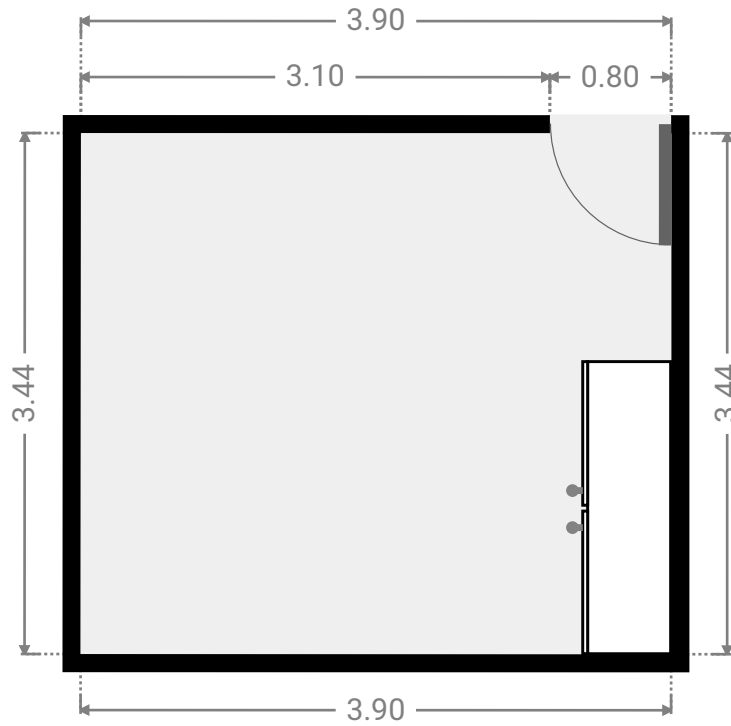
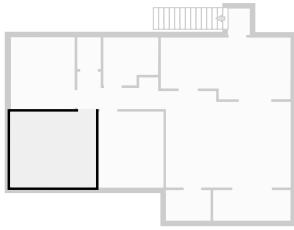

▼ **Bedroom**
1st Floor

WIDTH: 2.90 m • LENGTH: 3.27 m
AREA: 9.48 m² • PERIMETER: 12.34 m

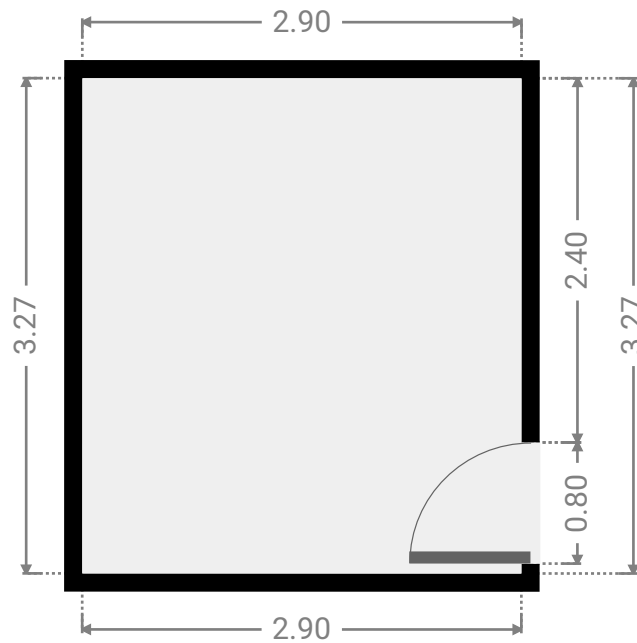
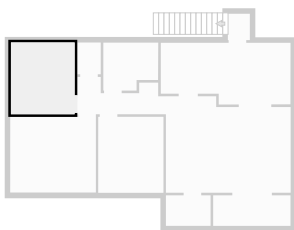

▼ **Hall**
1st Floor

WIDTH: 1.00 m • LENGTH: 1.20 m
AREA: 1.20 m² • PERIMETER: 4.40 m

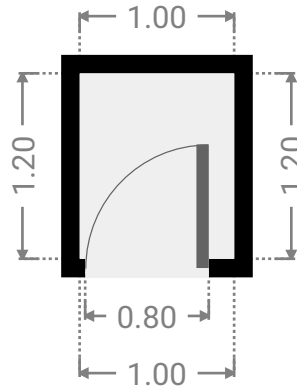
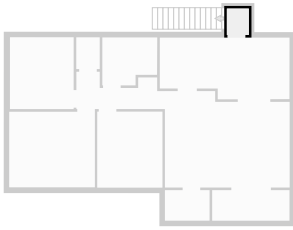

▼ **Hall**
1st Floor

WIDTH: 3.91 m • LENGTH: 1.70 m
AREA: 4.92 m² • PERIMETER: 12.18 m

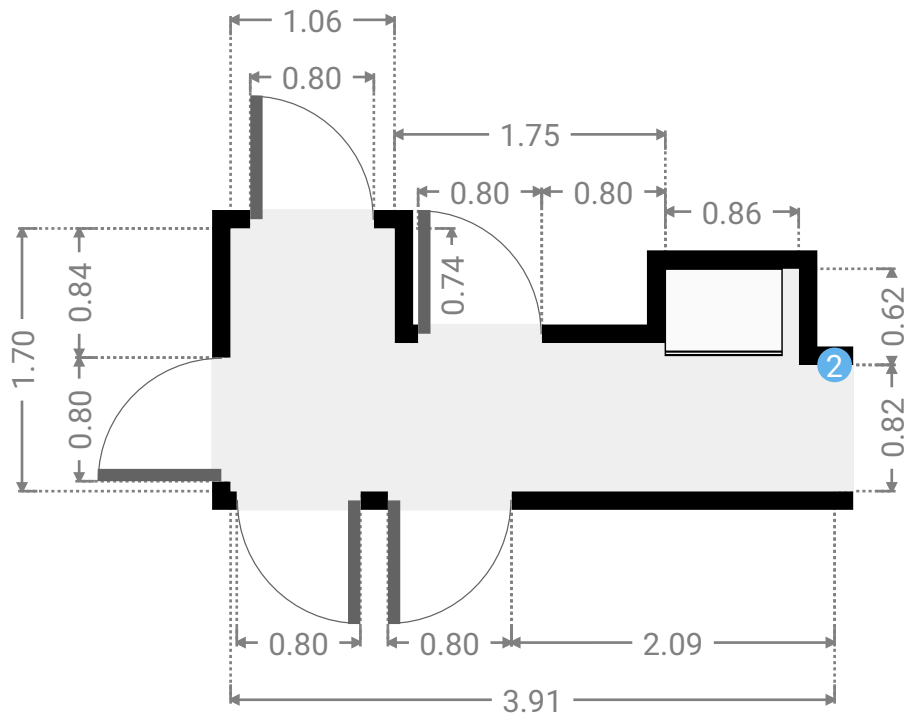
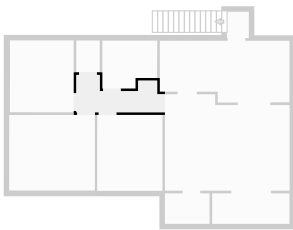

▼ Hall/1st Floor

2 OPENING

Height
0.00 m



▼ Kitchen
1st Floor

WIDTH: 5.91 m • LENGTH: 2.82 m
AREA: 15.27 m² • PERIMETER: 17.42 m

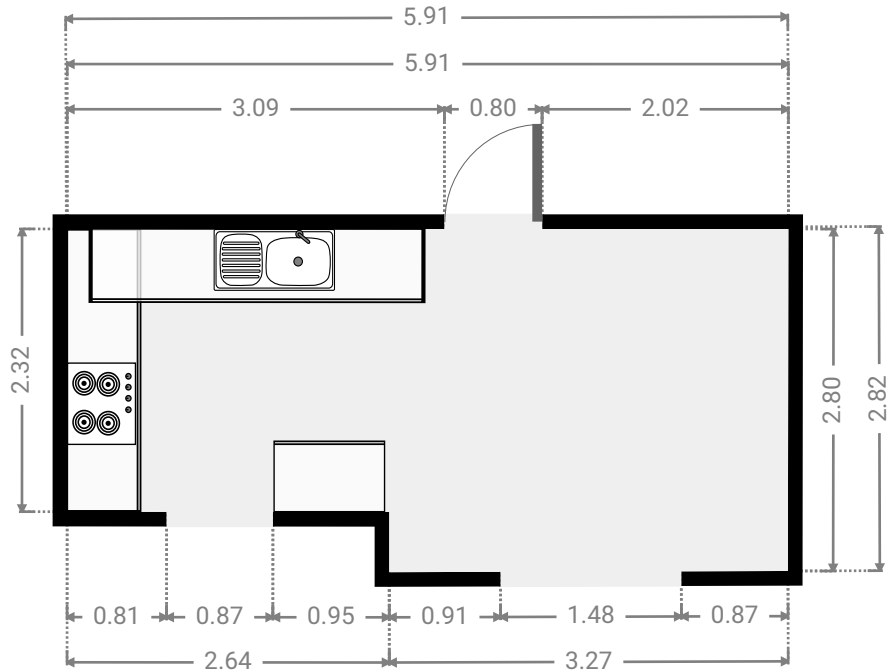
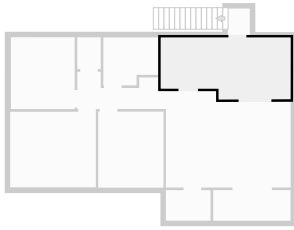

▼ Living Room
1st Floor

WIDTH: 5.68 m • LENGTH: 4.39 m
AREA: 23.27 m² • PERIMETER: 20.14 m

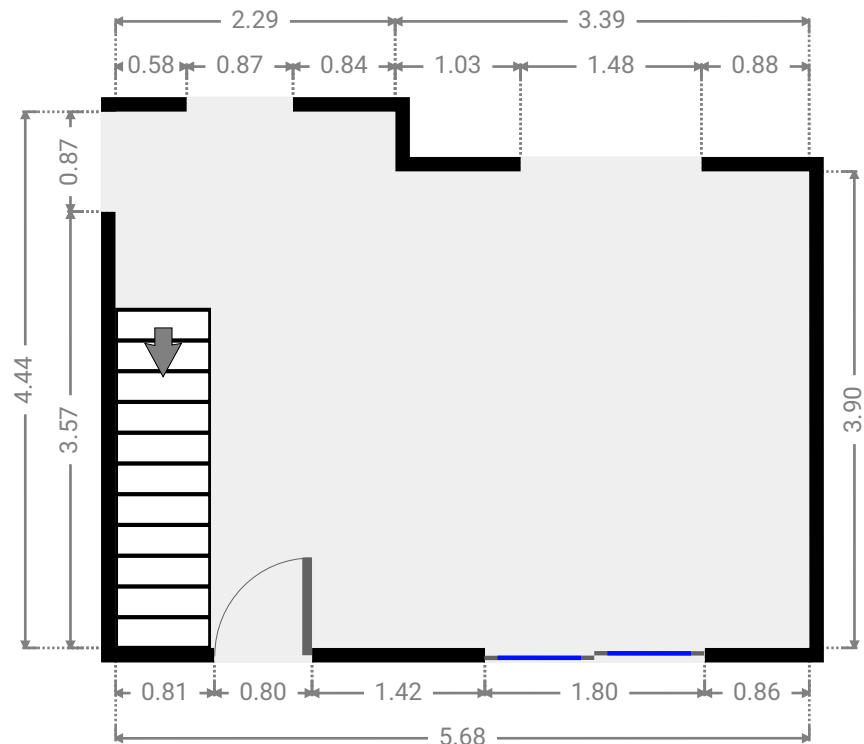
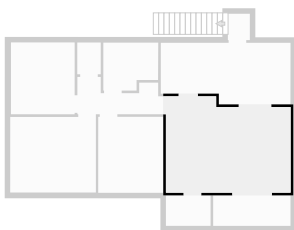

▼ Other
1st Floor

WIDTH: 3.52 m • LENGTH: 1.39 m
AREA: 4.89 m² • PERIMETER: 9.82 m

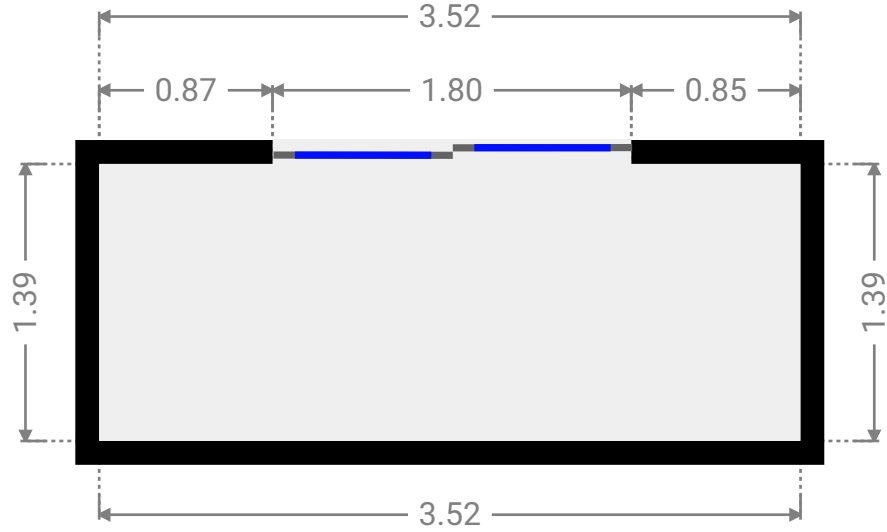
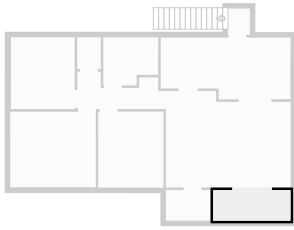

▼ Study
1st Floor

WIDTH: 2.03 m • LENGTH: 1.39 m
AREA: 2.82 m² • PERIMETER: 6.84 m

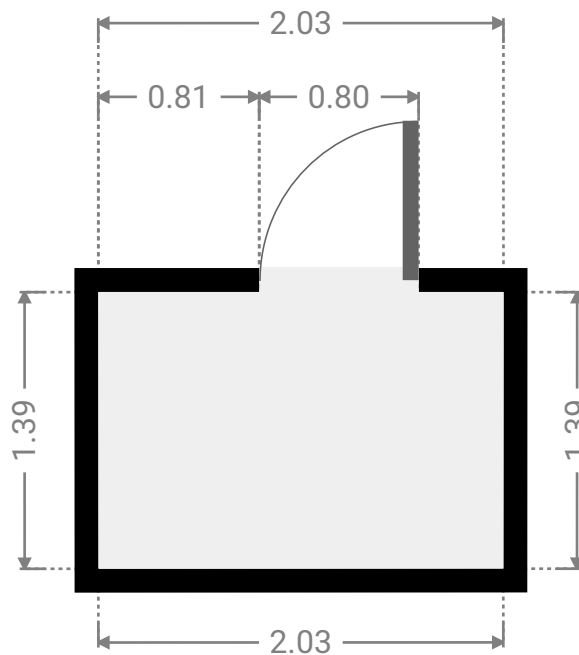
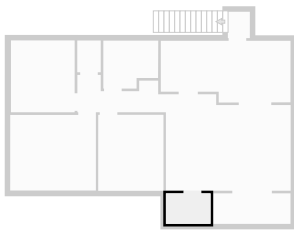

▼ Toilet
1st Floor

WIDTH: 1.07 m • LENGTH: 1.45 m
AREA: 1.54 m² • PERIMETER: 5.02 m

