

31 Schultz Street

SUBMITTED BY
Ray White Rockhampton Casey
stockers@cqoz.com

CREATED ON
2022-02-02

Floors
2

▼ Ground Floor

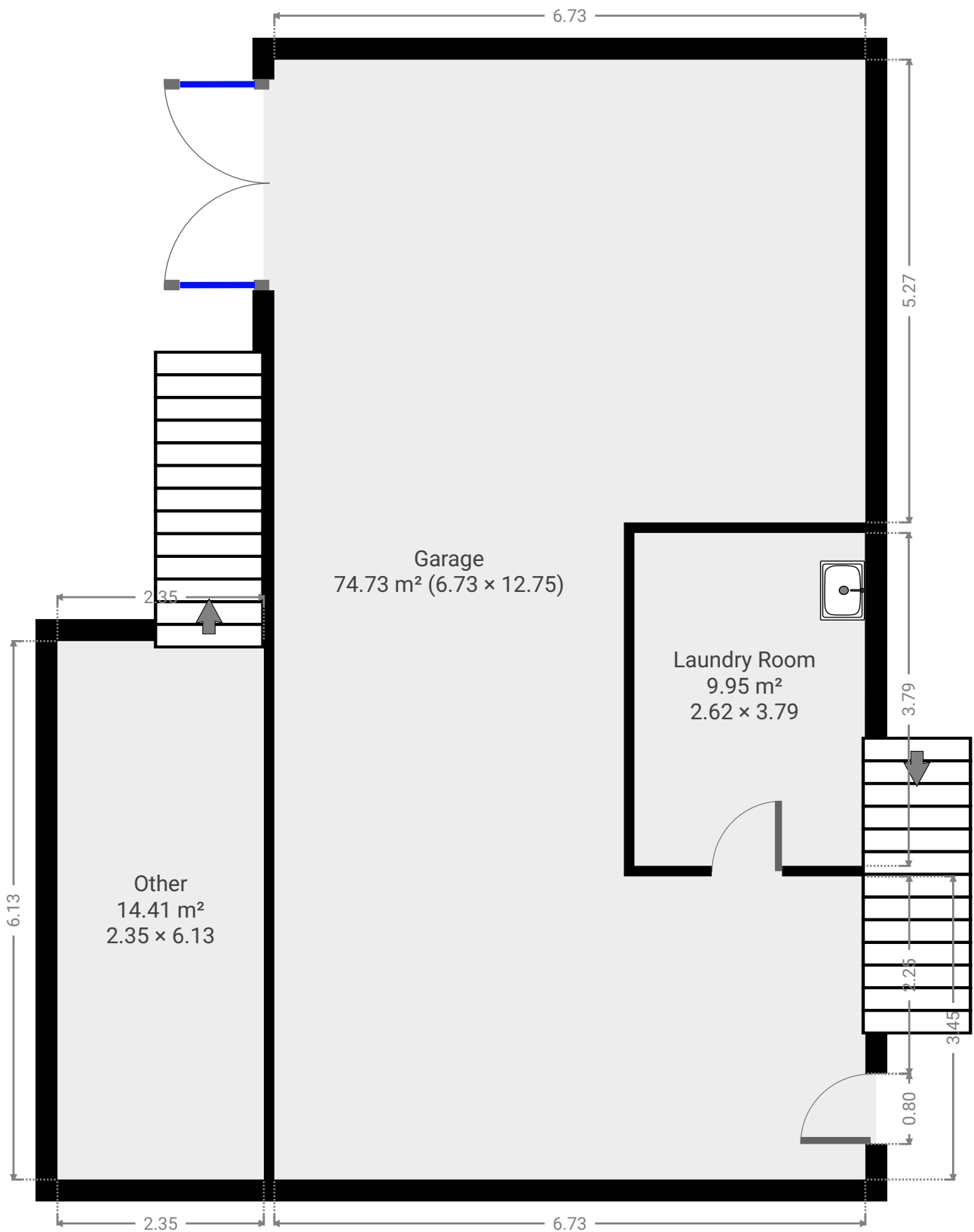

▼ **Garage**
Ground Floor

WIDTH: 12.75 m • LENGTH: 6.73 m
AREA: 74.73 m² • PERIMETER: 44.46 m

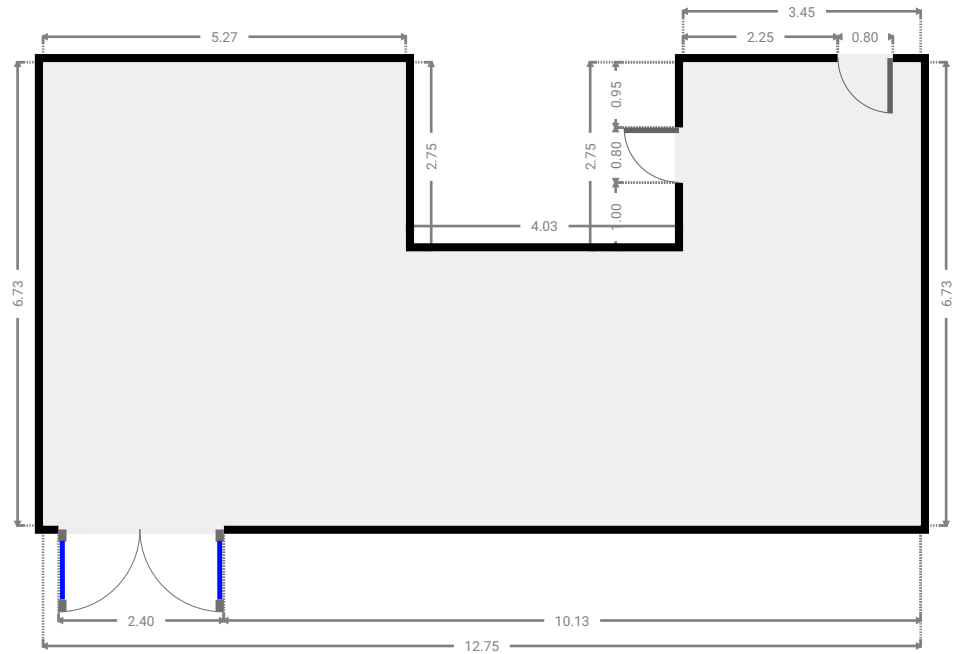
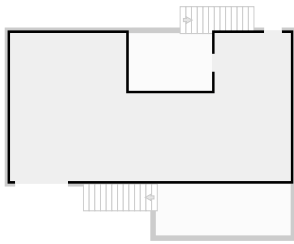

▼ **Laundry Room**
Ground Floor

WIDTH: 3.79 m • LENGTH: 2.63 m
AREA: 9.95 m² • PERIMETER: 12.83 m

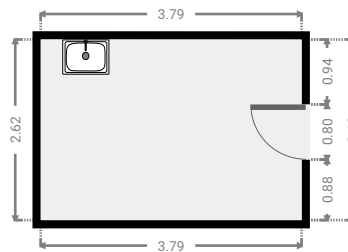
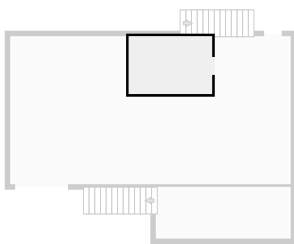

▼ Other
Ground Floor

WIDTH: 6.13 m • LENGTH: 2.35 m
AREA: 14.41 m² • PERIMETER: 16.96 m

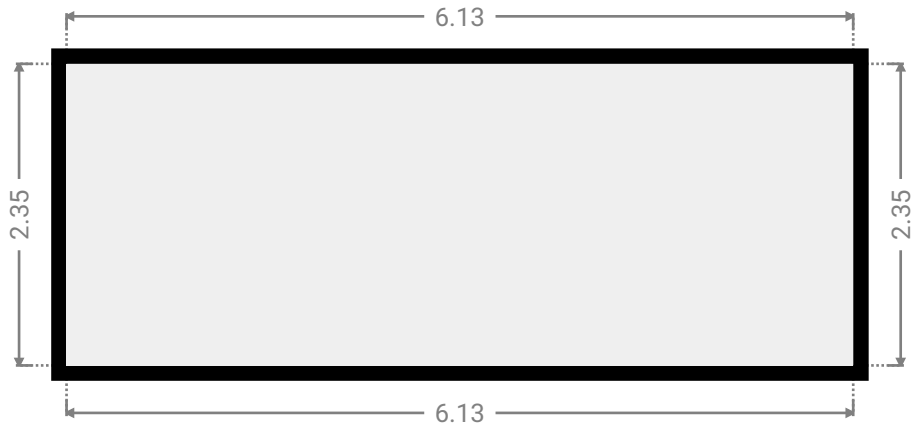
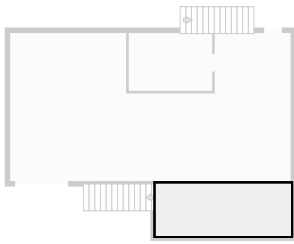

▼ 1st Floor

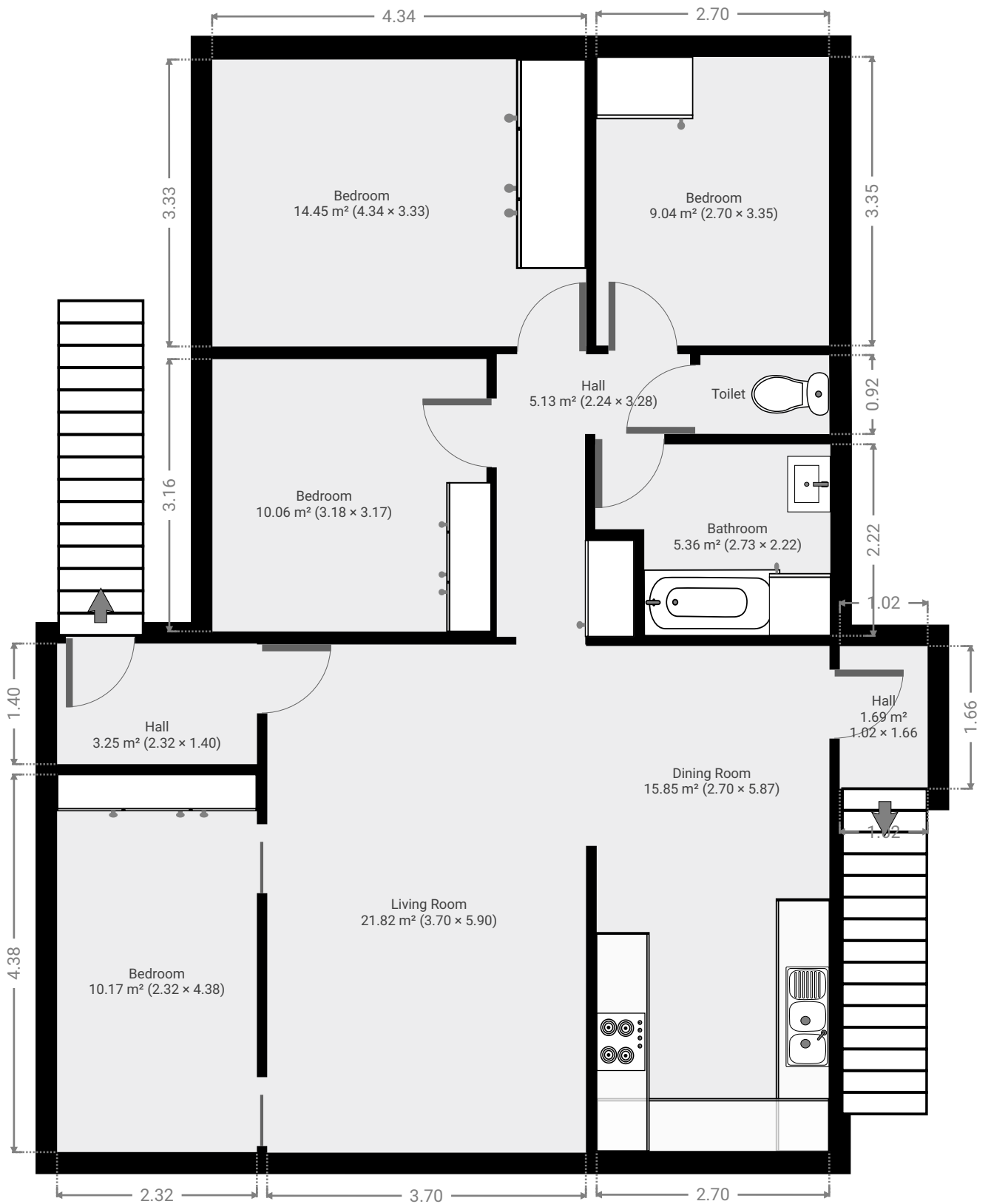

▼ **Hall**
1st Floor

WIDTH: 1.40 m • LENGTH: 2.32 m
AREA: 3.25 m² • PERIMETER: 7.44 m

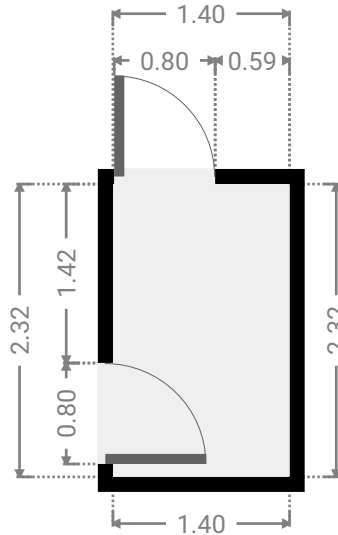
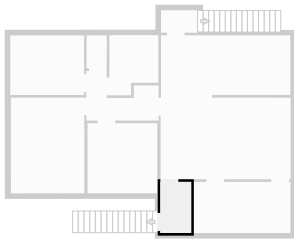

▼ **Living Room**
1st Floor

WIDTH: 5.90 m • LENGTH: 3.70 m
AREA: 21.82 m² • PERIMETER: 19.20 m

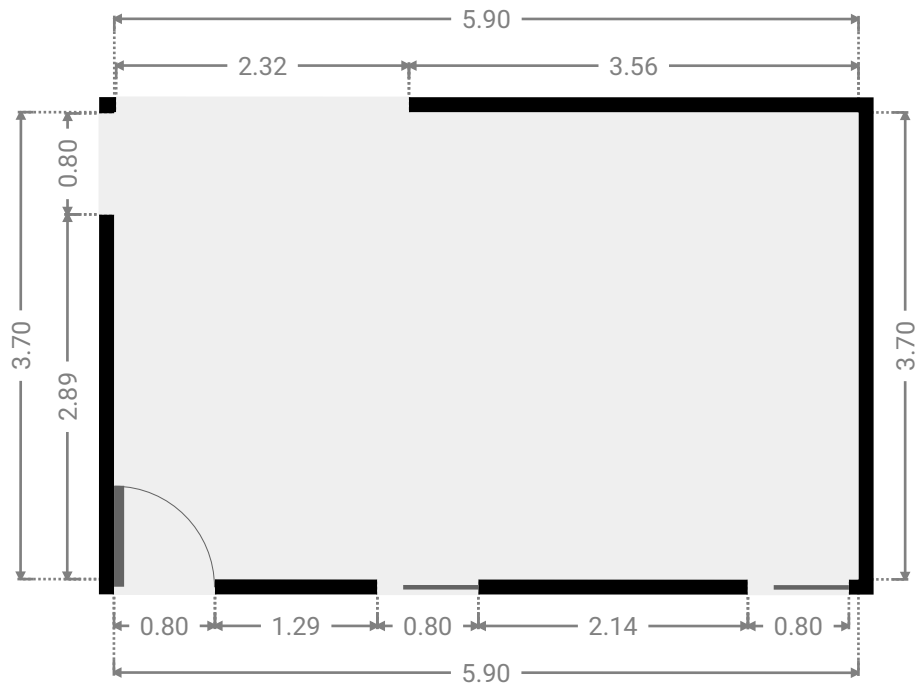
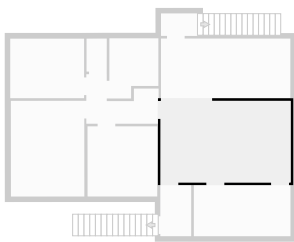

▼ **Bedroom**
1st Floor

WIDTH: 4.38 m • LENGTH: 2.32 m
AREA: 10.17 m² • PERIMETER: 13.41 m

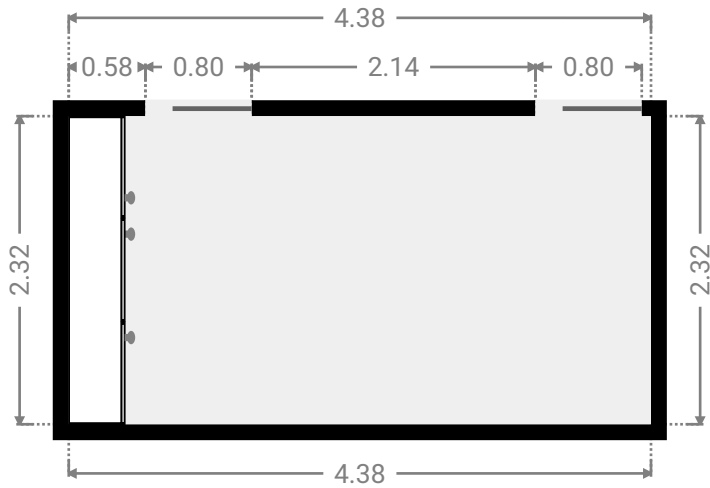
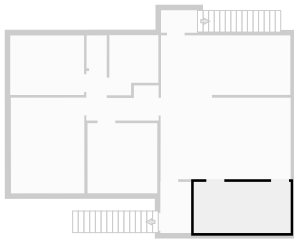

▼ **Dining Room**
1st Floor

WIDTH: 5.87 m • LENGTH: 2.70 m
AREA: 15.85 m² • PERIMETER: 17.14 m

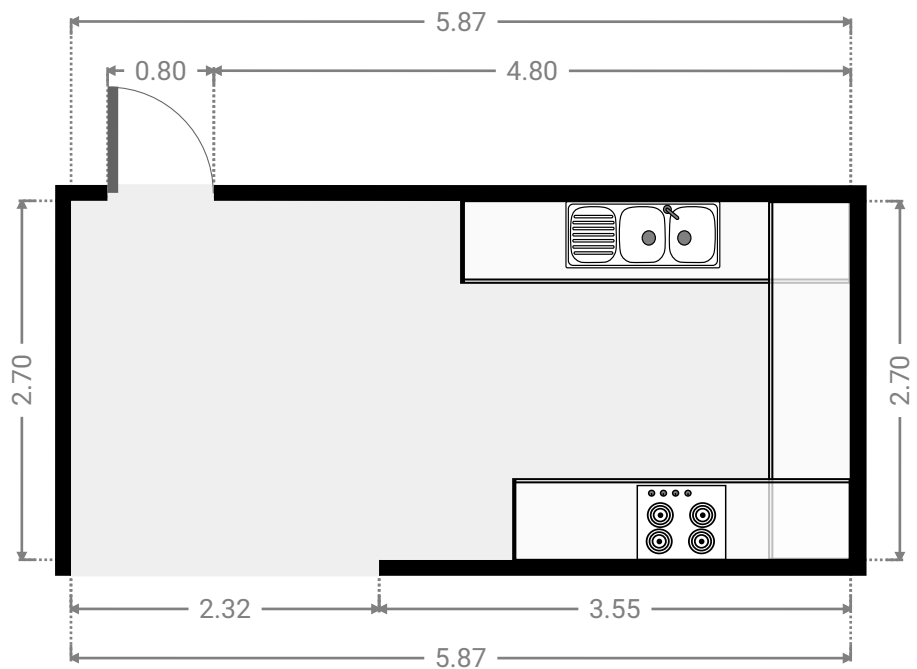
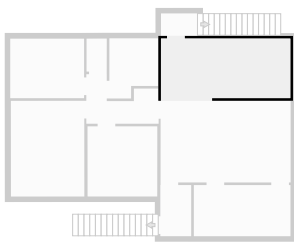

▼ **Hall**
1st Floor

WIDTH: 3.28 m • LENGTH: 2.24 m
AREA: 5.13 m² • PERIMETER: 12.18 m

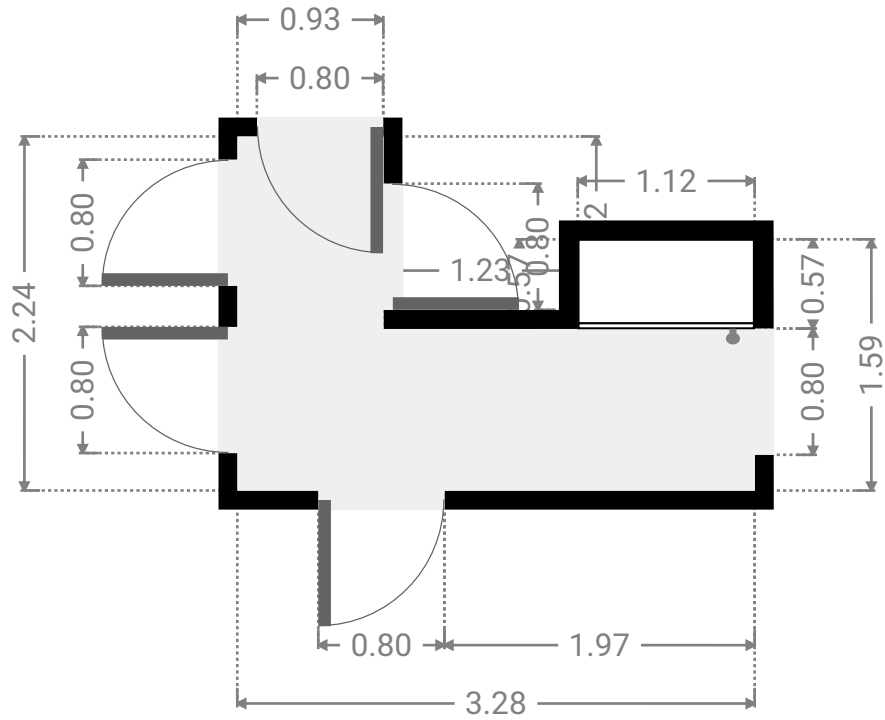
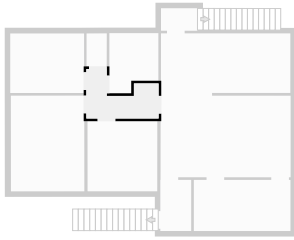

▼ **Bedroom**
1st Floor

WIDTH: 3.17 m • LENGTH: 3.18 m
AREA: 10.06 m² • PERIMETER: 12.69 m

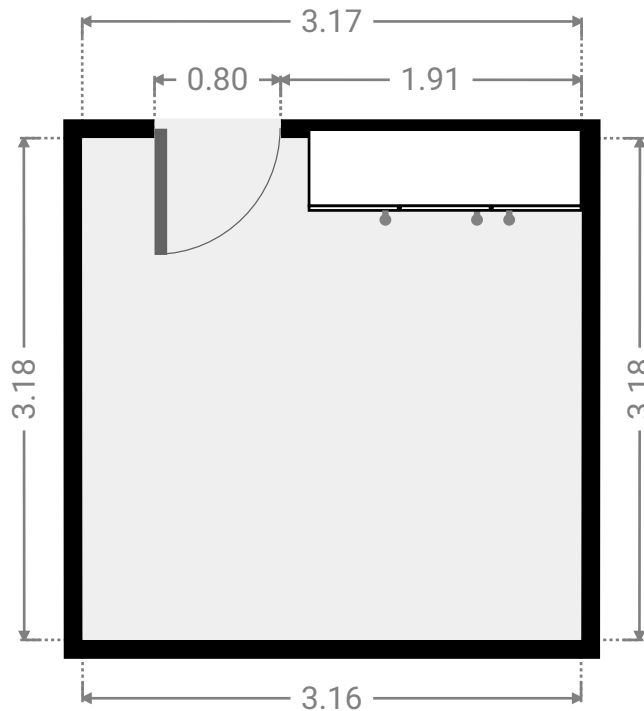
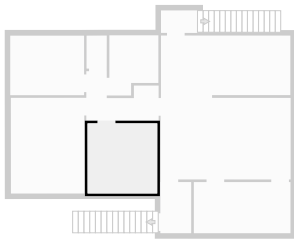

▼ **Bedroom**
1st Floor

WIDTH: 3.33 m • LENGTH: 4.34 m
AREA: 14.45 m² • PERIMETER: 15.34 m

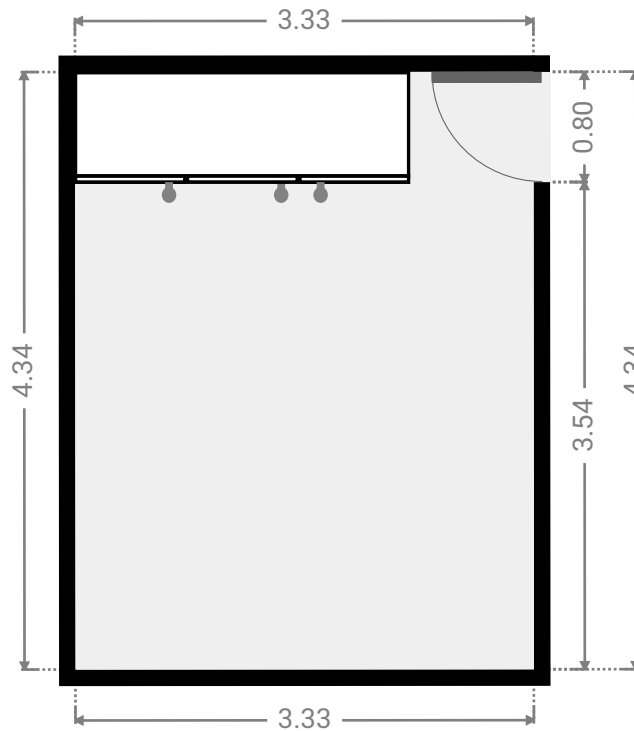
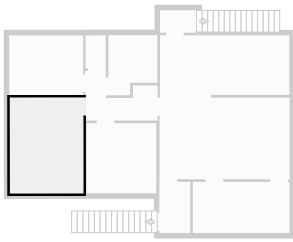

▼ **Bedroom**
1st Floor

WIDTH: 3.35 m • LENGTH: 2.70 m
AREA: 9.04 m² • PERIMETER: 12.10 m

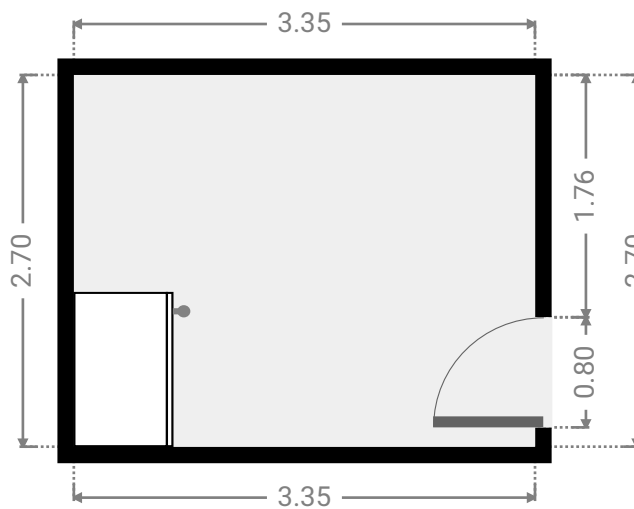
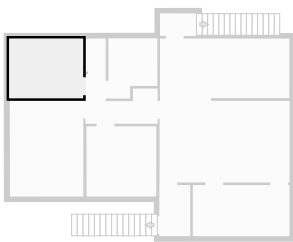

▼ **Bathroom**
1st Floor

WIDTH: 2.22 m • LENGTH: 2.73 m
AREA: 5.36 m² • PERIMETER: 9.90 m

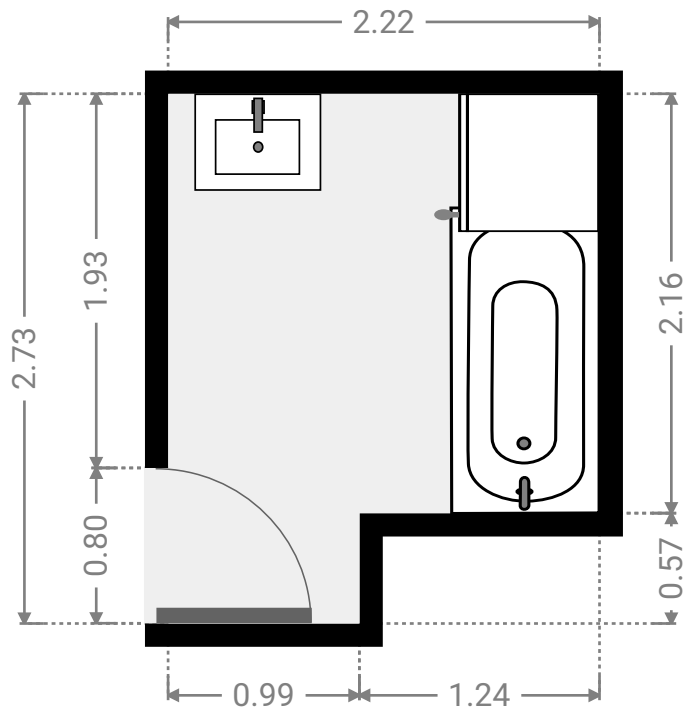
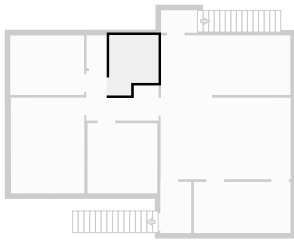

▼ **Toilet**
1st Floor

WIDTH: 0.92 m • LENGTH: 1.50 m
AREA: 1.37 m² • PERIMETER: 4.82 m

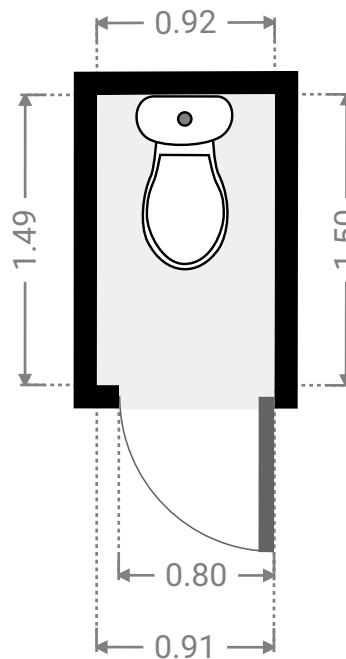
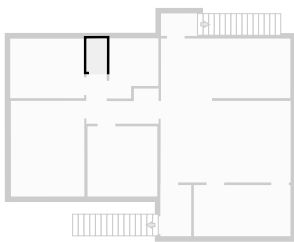

▼ **Hall**
1st Floor

WIDTH: 1.66 m • LENGTH: 1.02 m
AREA: 1.69 m² • PERIMETER: 5.35 m

