

# 309 Empire Apartment

**SUBMITTED BY**

Ray White Rockhampton Casey  
stockers@cqoz.com

---

**CREATED ON**

2022-09-28

---

**Floors**

1

---

## ▼ 3rd Floor

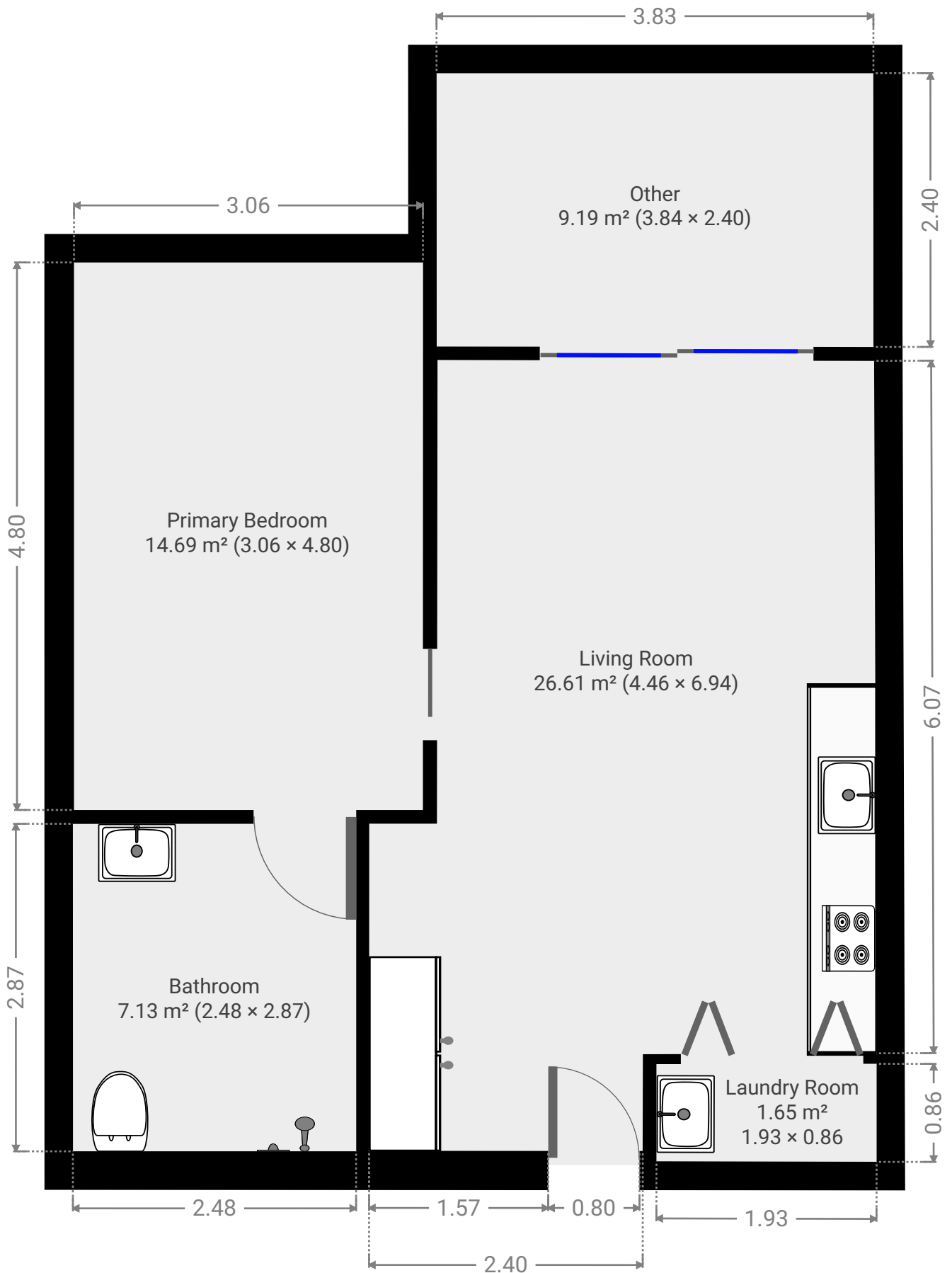

## ▼ Bathroom 3rd Floor

WIDTH: 2.48 m • LENGTH: 2.87 m  
AREA: 7.13 m<sup>2</sup> • PERIMETER: 10.71 m

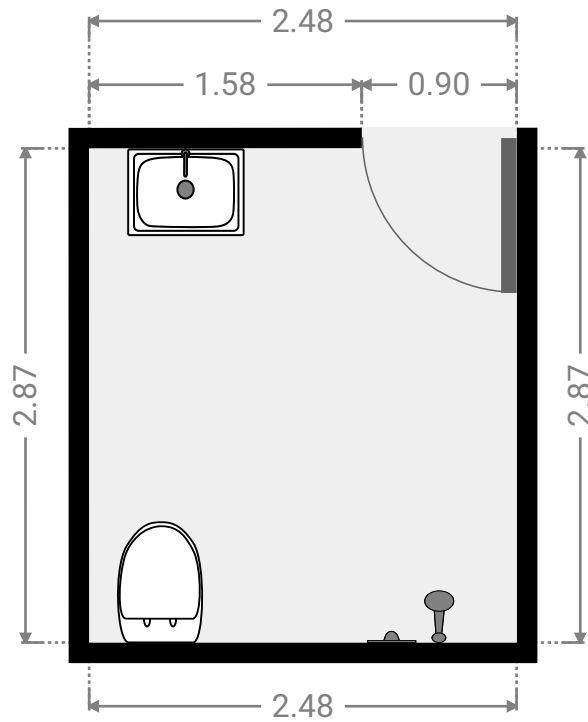
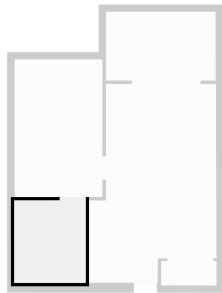

## ▼ Laundry Room 3rd Floor

WIDTH: 1.93 m • LENGTH: 0.86 m  
AREA: 1.65 m<sup>2</sup> • PERIMETER: 5.57 m

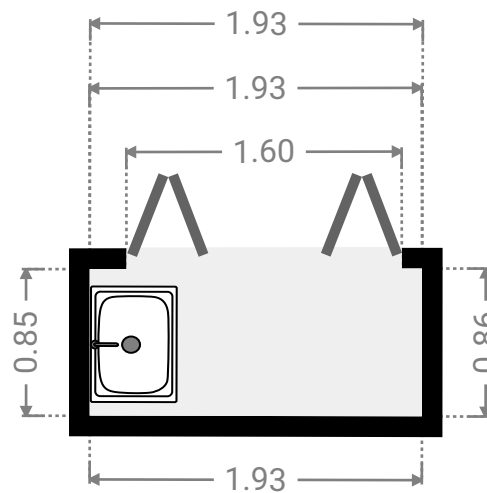
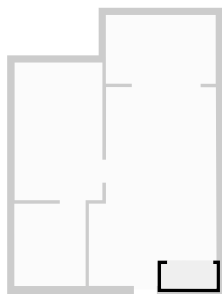

▼ **Living Room**  
3rd Floor

WIDTH: 4.46 m • LENGTH: 6.94 m  
AREA: 26.61 m<sup>2</sup> • PERIMETER: 22.73 m

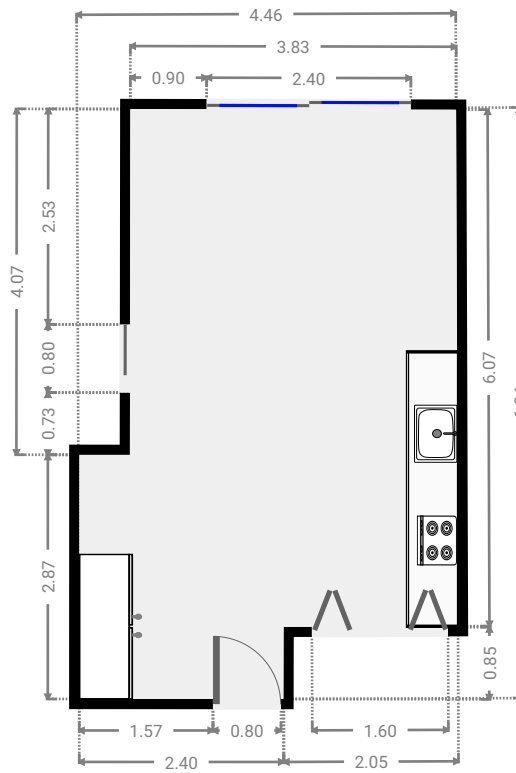
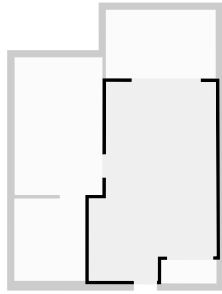

▼ **Other**  
3rd Floor

WIDTH: 3.84 m • LENGTH: 2.40 m  
AREA: 9.19 m<sup>2</sup> • PERIMETER: 12.46 m

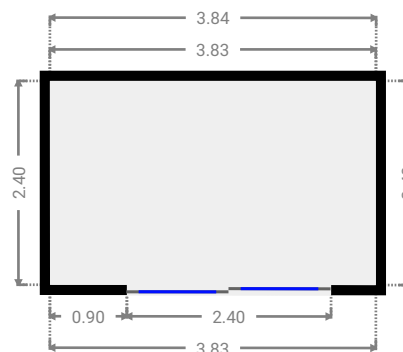
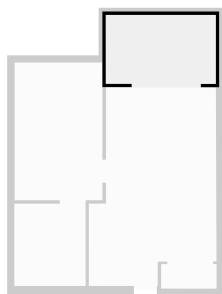

## ▼ Primary Bedroom 3rd Floor

WIDTH: 3.06 m • LENGTH: 4.80 m  
AREA: 14.69 m<sup>2</sup> • PERIMETER: 15.72 m

