

306 Upper Dawson Road

Created on
2021-04-08

Floors
2

▼ Ground Floor

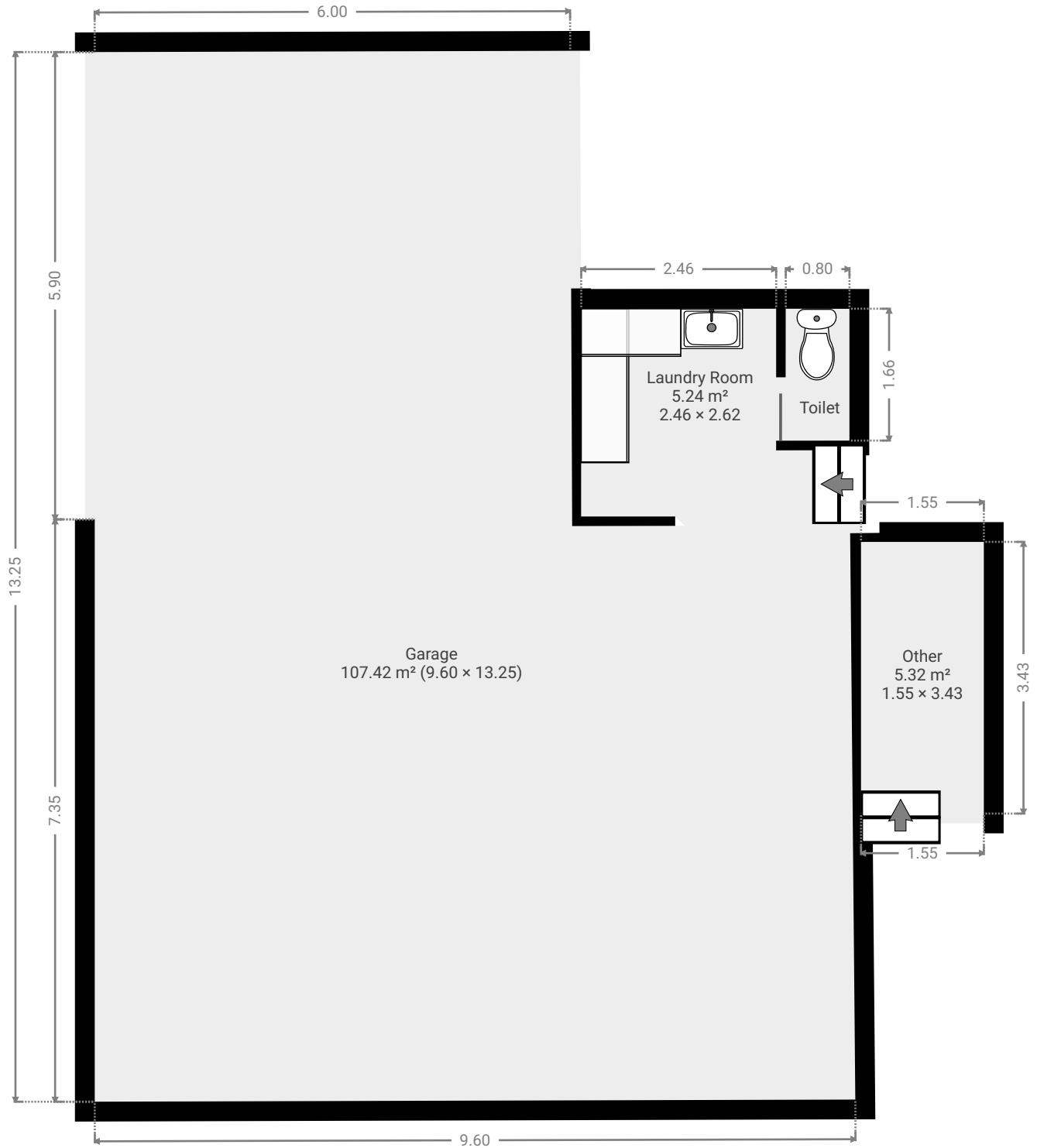

▼ **Garage**
Ground Floor

WIDTH: 13.25 m • LENGTH: 9.60 m
AREA: 107.42 m² • PERIMETER: 47.50 m

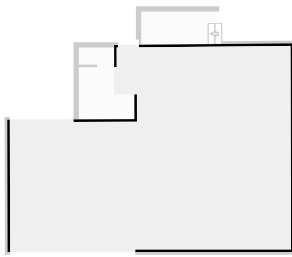

▼ **Laundry Room**
Ground Floor

WIDTH: 2.62 m • LENGTH: 2.46 m
AREA: 5.24 m² • PERIMETER: 10.17 m

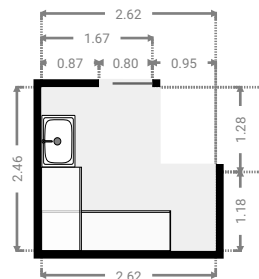
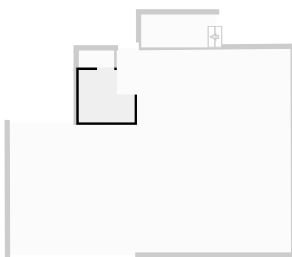

▼ **Toilet**
Ground Floor

WIDTH: 1.67 m • LENGTH: 0.81 m
AREA: 1.34 m² • PERIMETER: 4.94 m

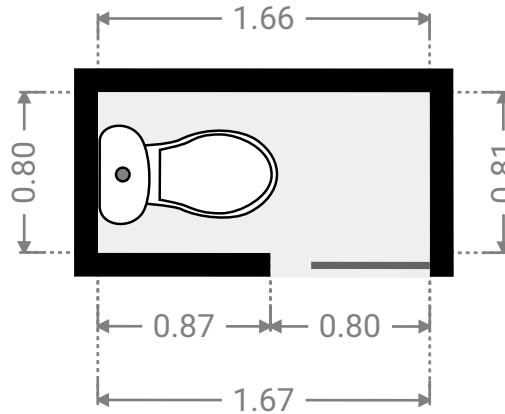
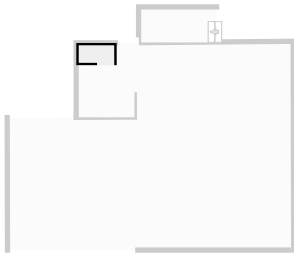

▼ **Other**
Ground Floor

WIDTH: 3.43 m • LENGTH: 1.55 m
AREA: 5.32 m² • PERIMETER: 9.96 m

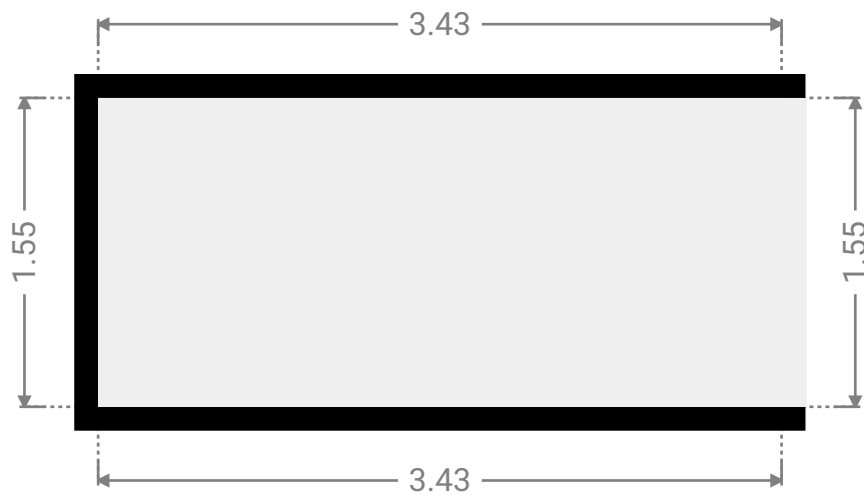
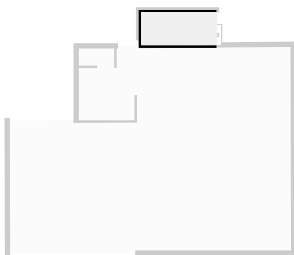

▼ 1st Floor

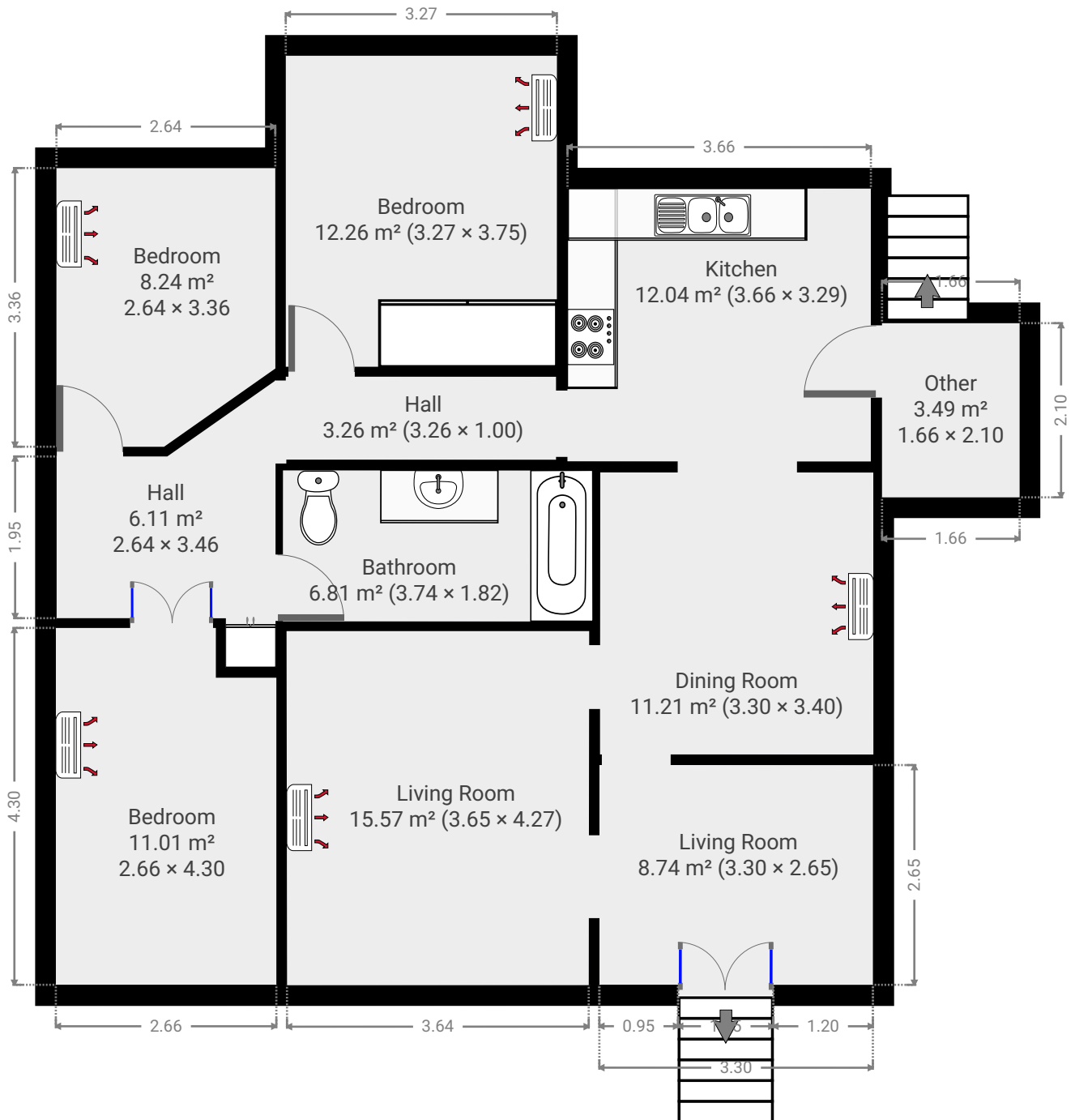

▼ Living Room
1st Floor

WIDTH: 3.30 m • LENGTH: 2.65 m
AREA: 8.74 m² • PERIMETER: 11.90 m

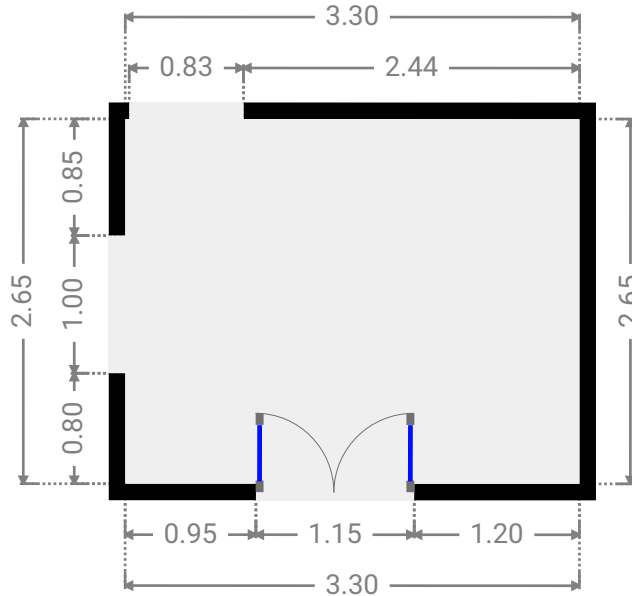
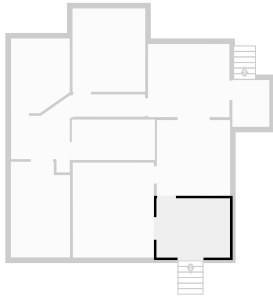

▼ Living Room
1st Floor

WIDTH: 3.65 m • LENGTH: 4.27 m
AREA: 15.57 m² • PERIMETER: 15.83 m

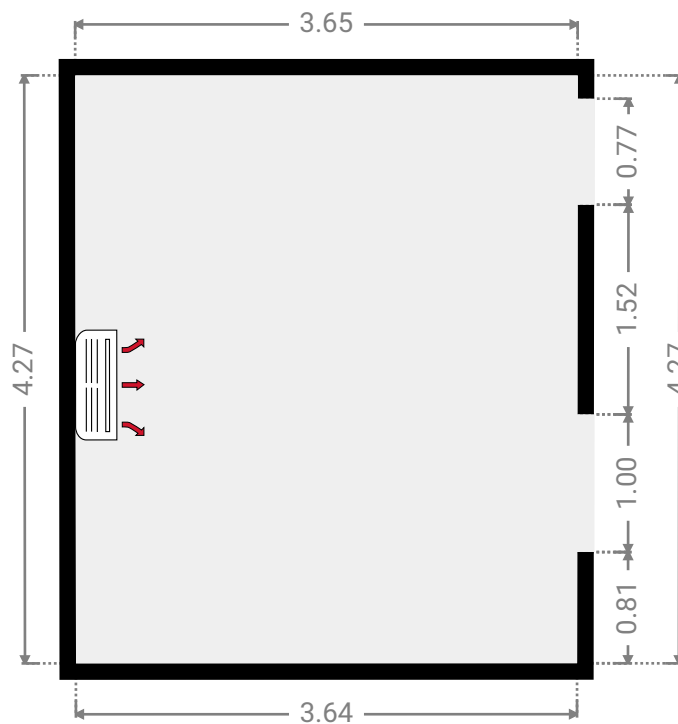
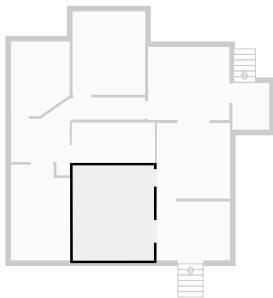

▼ **Dining Room**
1st Floor

WIDTH: 3.30 m • LENGTH: 3.40 m
AREA: 11.21 m² • PERIMETER: 13.40 m

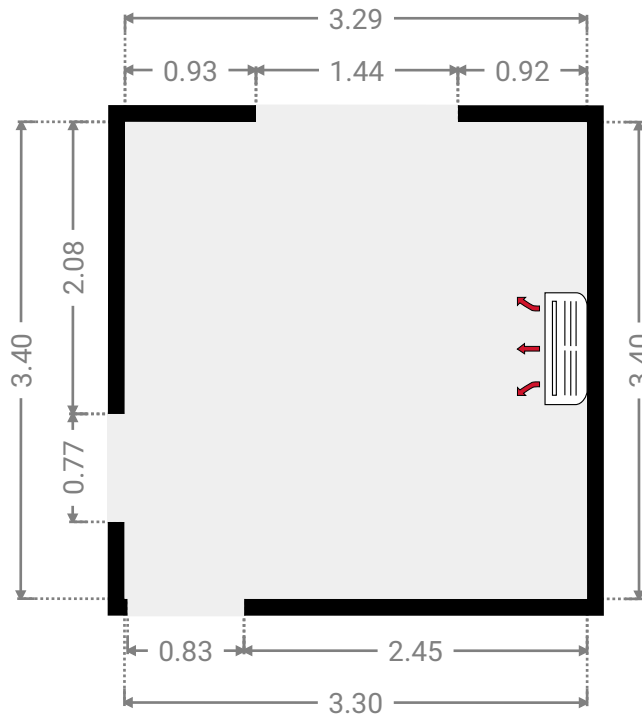
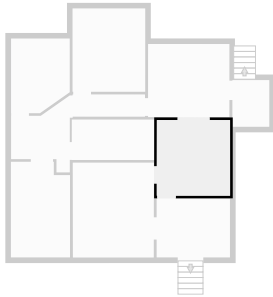

▼ **Kitchen**
1st Floor

WIDTH: 3.66 m • LENGTH: 3.29 m
AREA: 12.04 m² • PERIMETER: 13.90 m

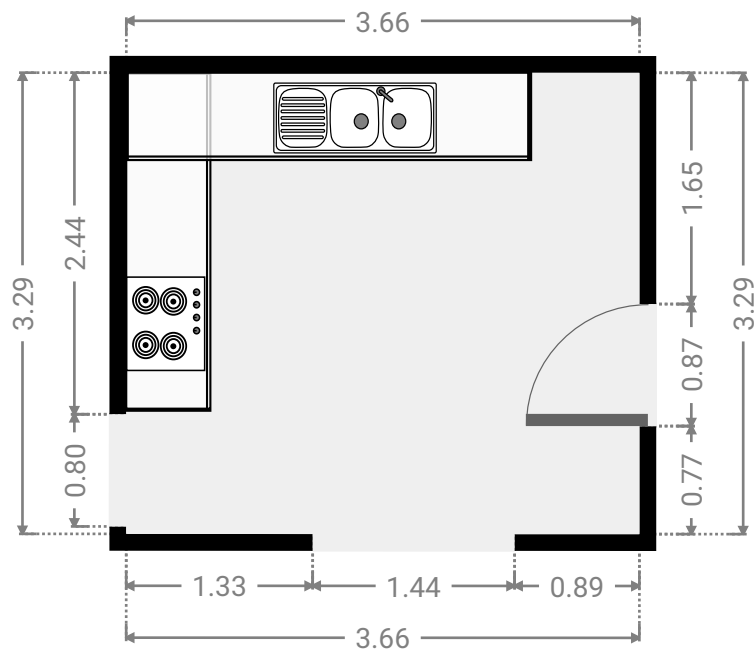
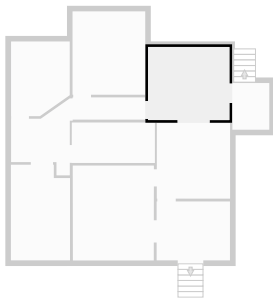

▼ **Hall**
1st Floor

WIDTH: 3.26 m • LENGTH: 1.00 m
AREA: 3.26 m² • PERIMETER: 8.52 m

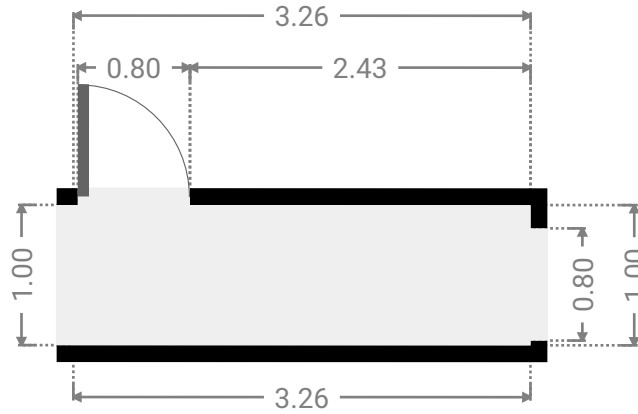
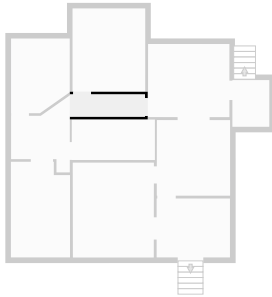

▼ **Bedroom**
1st Floor

WIDTH: 3.27 m • LENGTH: 3.75 m
AREA: 12.26 m² • PERIMETER: 14.04 m

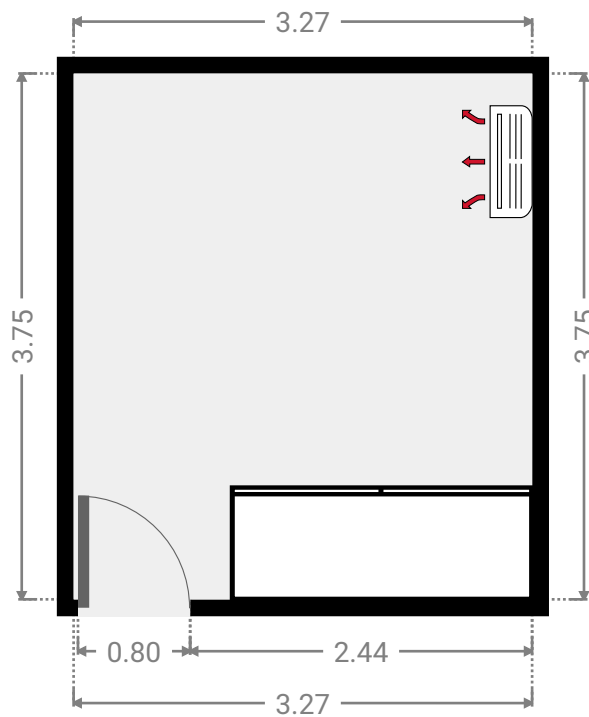
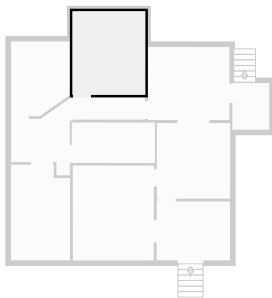

▼ Bathroom
1st Floor

WIDTH: 3.74 m • LENGTH: 1.82 m
AREA: 6.81 m² • PERIMETER: 11.12 m

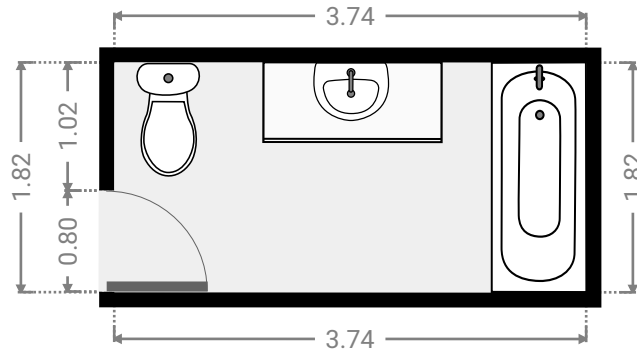
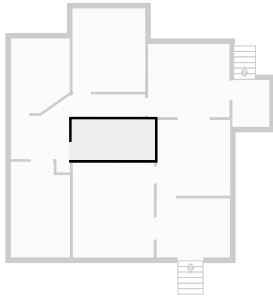

▼ Hall
1st Floor

WIDTH: 2.64 m • LENGTH: 3.46 m
AREA: 6.11 m² • PERIMETER: 11.58 m

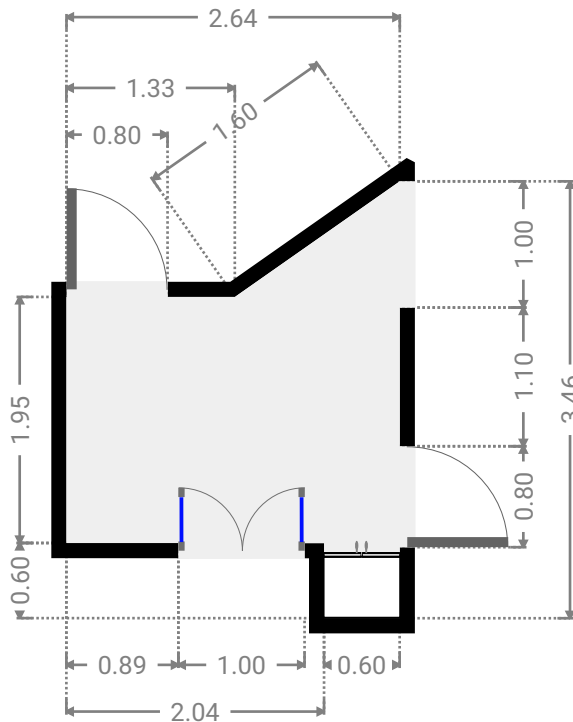
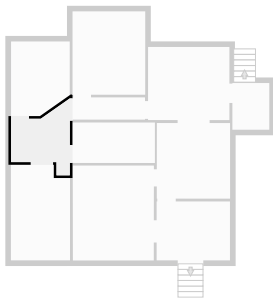

▼ **Bedroom**
1st Floor

WIDTH: 2.64 m • LENGTH: 3.36 m
AREA: 8.24 m² • PERIMETER: 11.35 m

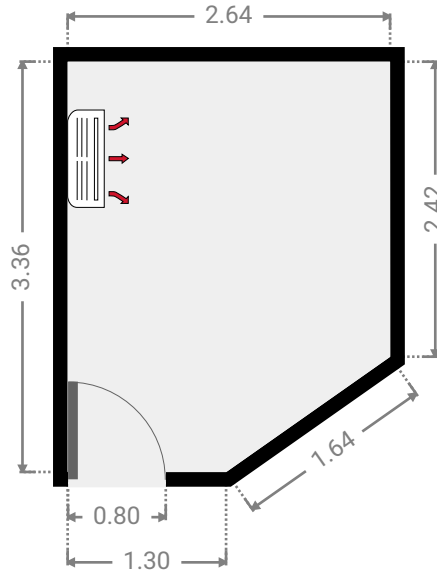
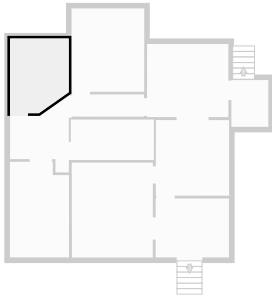

▼ **Bedroom**
1st Floor

WIDTH: 2.66 m • LENGTH: 4.30 m
AREA: 11.01 m² • PERIMETER: 13.93 m

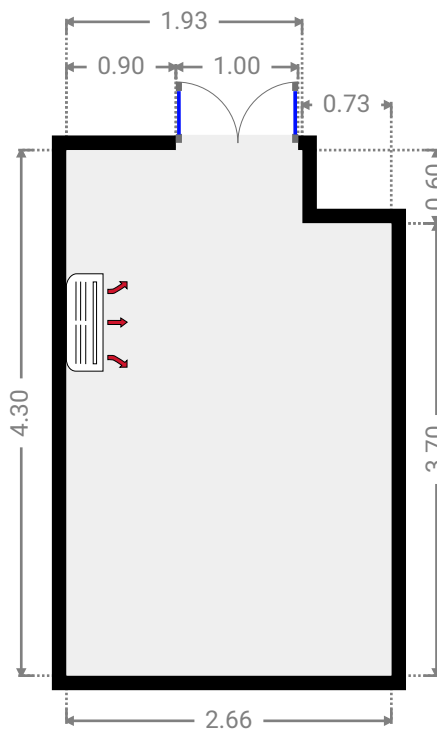
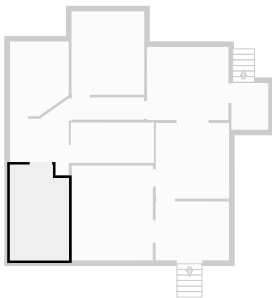

▼ Other
1st Floor

WIDTH: 1.66 m • LENGTH: 2.10 m
AREA: 3.49 m² • PERIMETER: 7.52 m

