

302 Everingham Avenue

Ground Floor

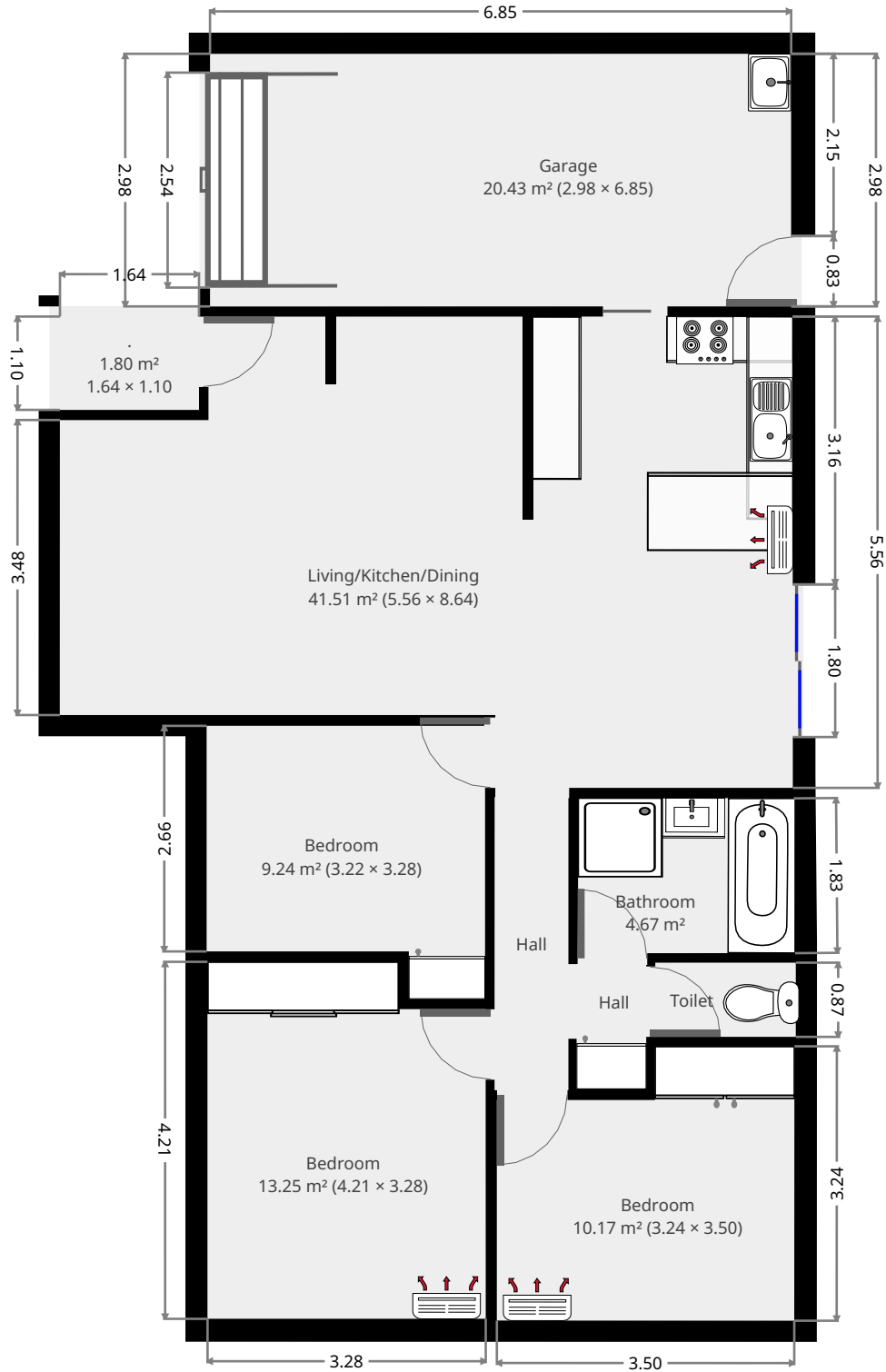

THIS FLOORPLAN IS PROVIDED WITHOUT WARRANTY OF ANY KIND. SENSOPIA DISCLAIMS ANY WARRANTY INCLUDING, WITHOUT LIMITATION, SATISFACTORY QUALITY OR ACCURACY OF DIMENSIONS.



302 Everingham Avenue

Living/Kitchen/Dining

Width: 5.56 m
 Length: 8.64 m
 Area: 41.51 m²
 Perimeter: 28.41 m

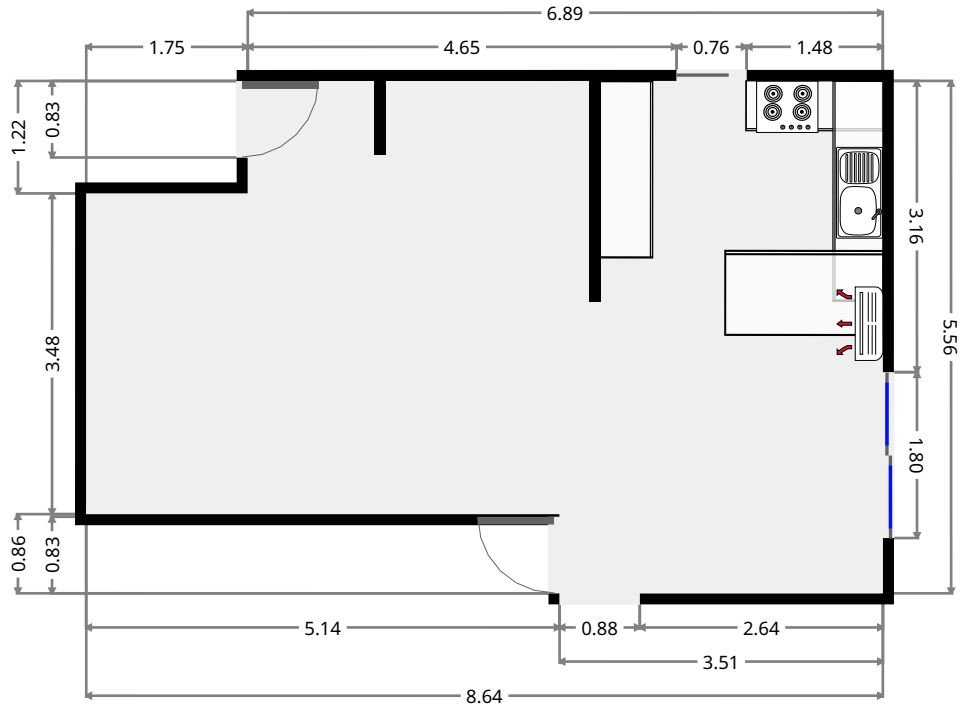
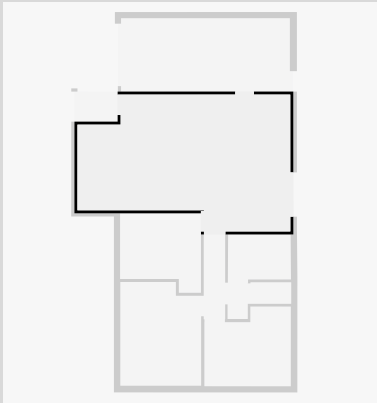

Garage

Width: 2.98 m
 Length: 6.85 m
 Area: 20.43 m²
 Perimeter: 19.67 m

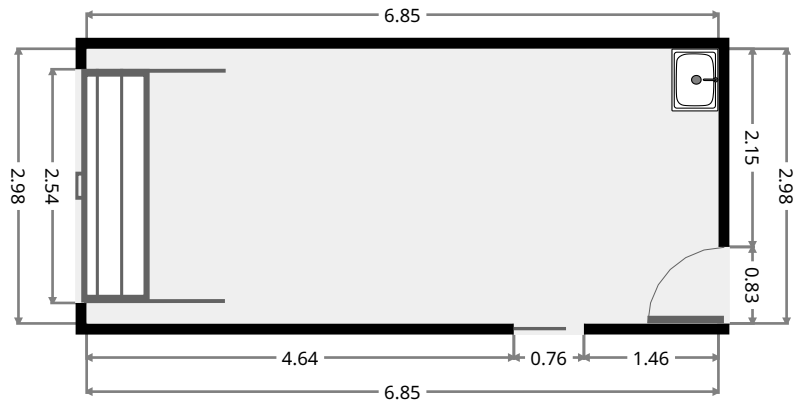
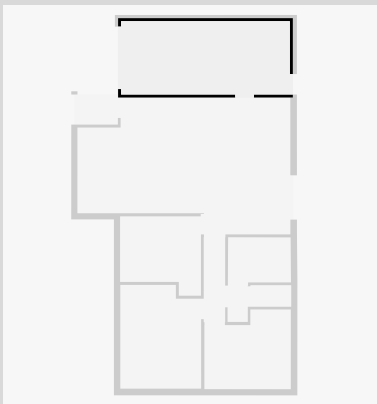

THIS FLOORPLAN IS PROVIDED WITHOUT WARRANTY OF ANY KIND. SENSOPIA DISCLAIMS ANY WARRANTY INCLUDING, WITHOUT LIMITATION, SATISFACTORY QUALITY OR ACCURACY OF DIMENSIONS.



302 Everingham Avenue

Hall

Width: 0.88 m
 Length: 3.46 m
 Area: 3.01 m²
 Perimeter: 8.65 m

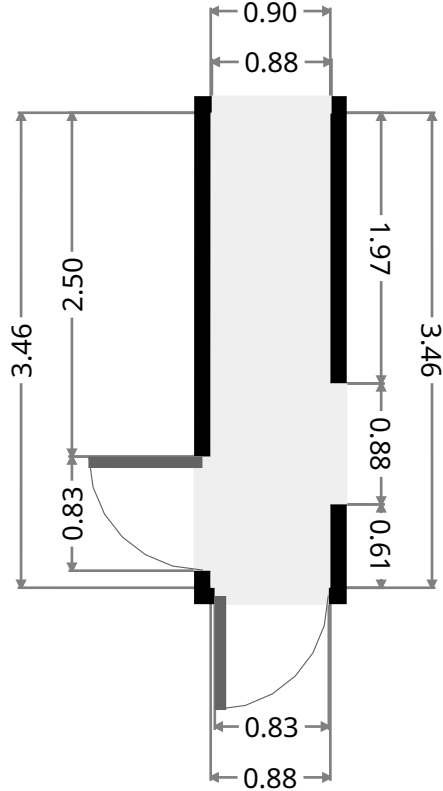
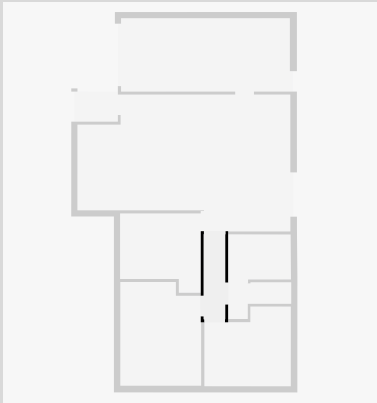

Bedroom

Width: 3.22 m
 Length: 3.28 m
 Area: 9.24 m²
 Perimeter: 13.01 m

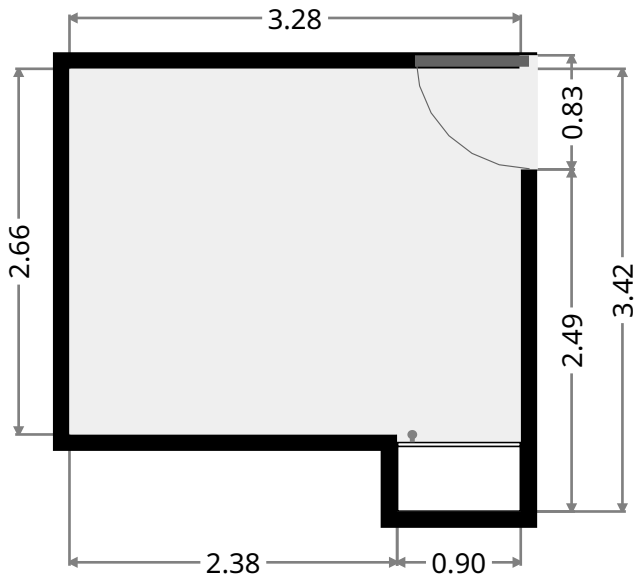
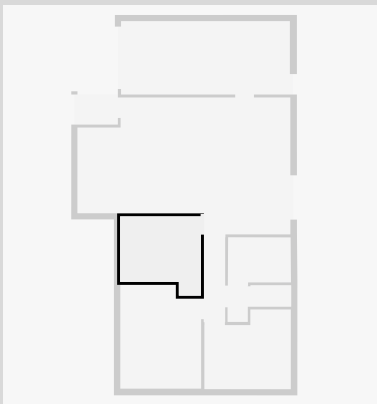

302 Everingham Avenue

Bedroom

Width: 3.28 m
 Length: 4.21 m
 Area: 13.25 m²
 Perimeter: 14.99 m

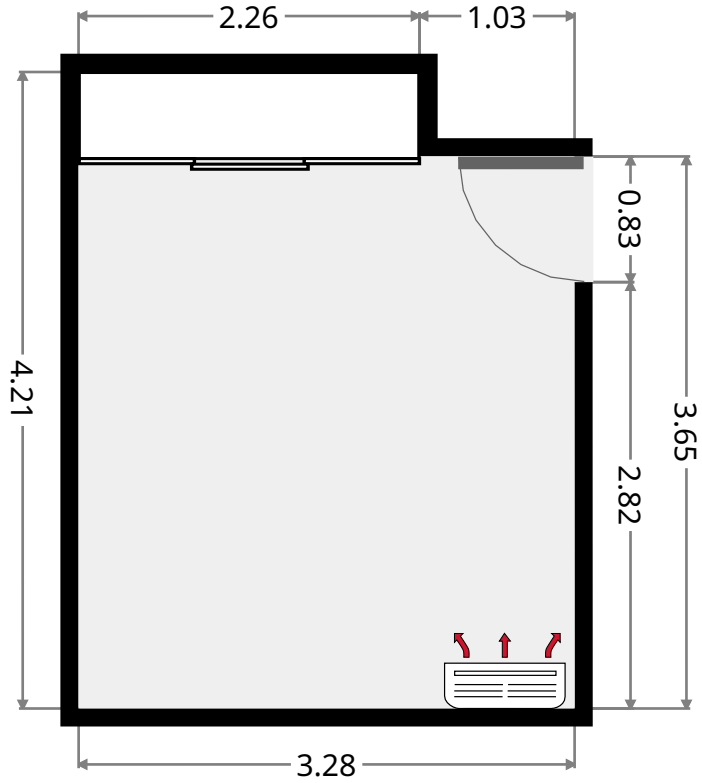
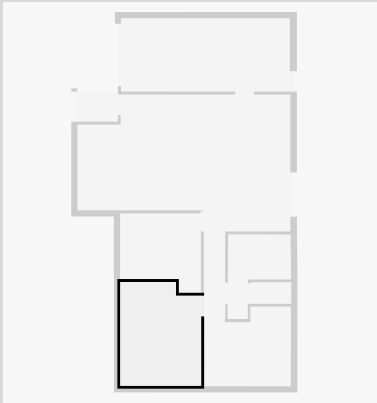

Bedroom

Width: 3.24 m
 Length: 3.50 m
 Area: 10.17 m²
 Perimeter: 13.49 m

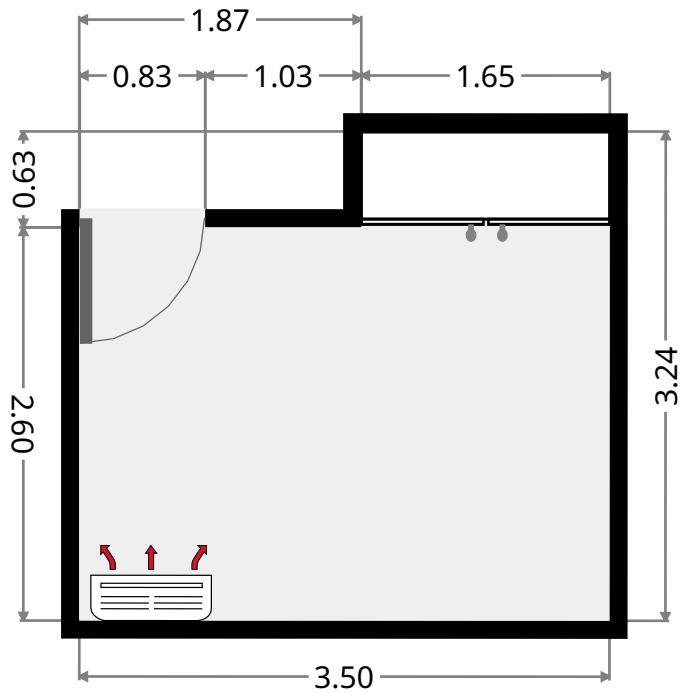
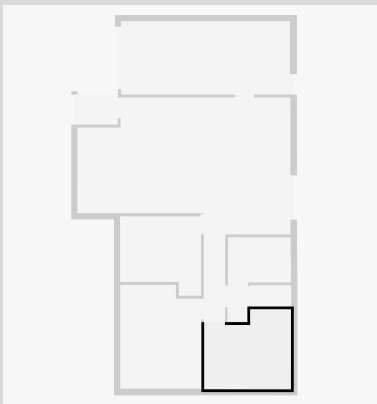

302 Everingham Avenue

Hall

Width: 0.82 m
 Length: 1.48 m
 Area: 1.21 m²
 Perimeter: 4.59 m

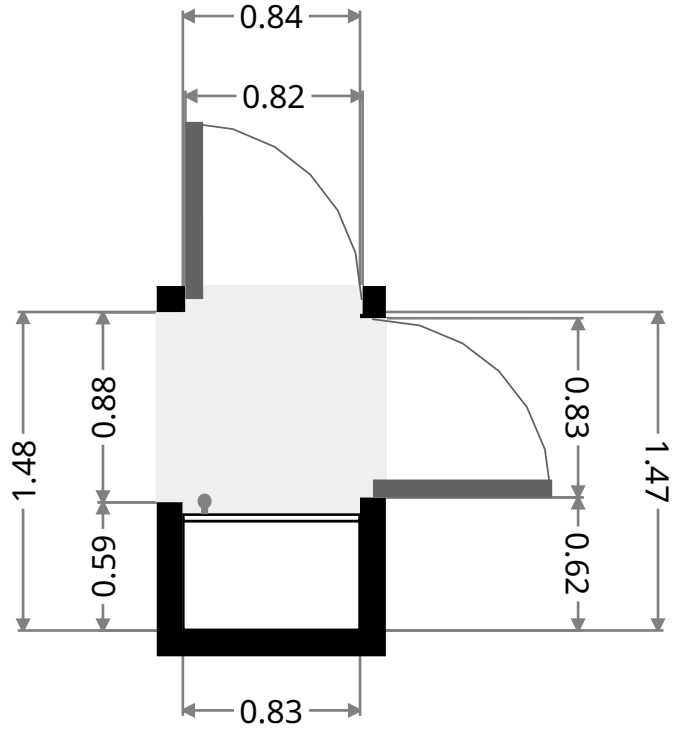
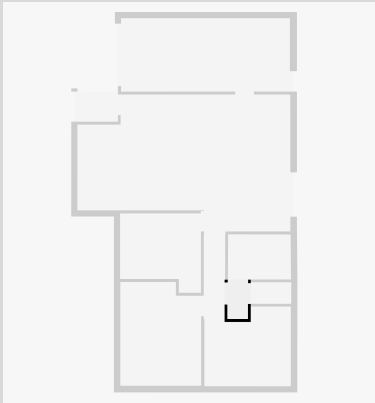

Toilet / Half Bath

Width: 0.87 m
 Length: 1.66 m
 Area: 1.45 m²
 Perimeter: 5.06 m

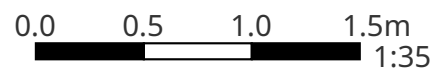
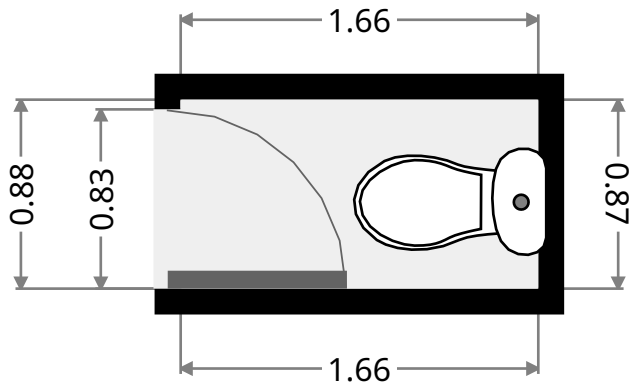
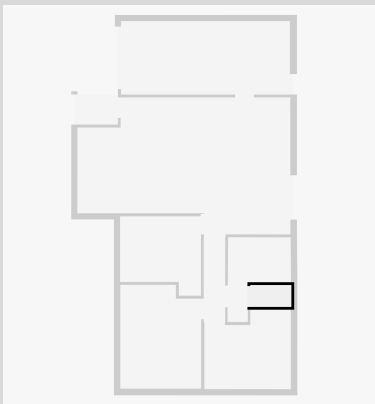

302 Everingham Avenue

Bathroom

Width: 1.83 m
 Length: 2.56 m
 Area: 4.67 m²
 Perimeter: 8.76 m

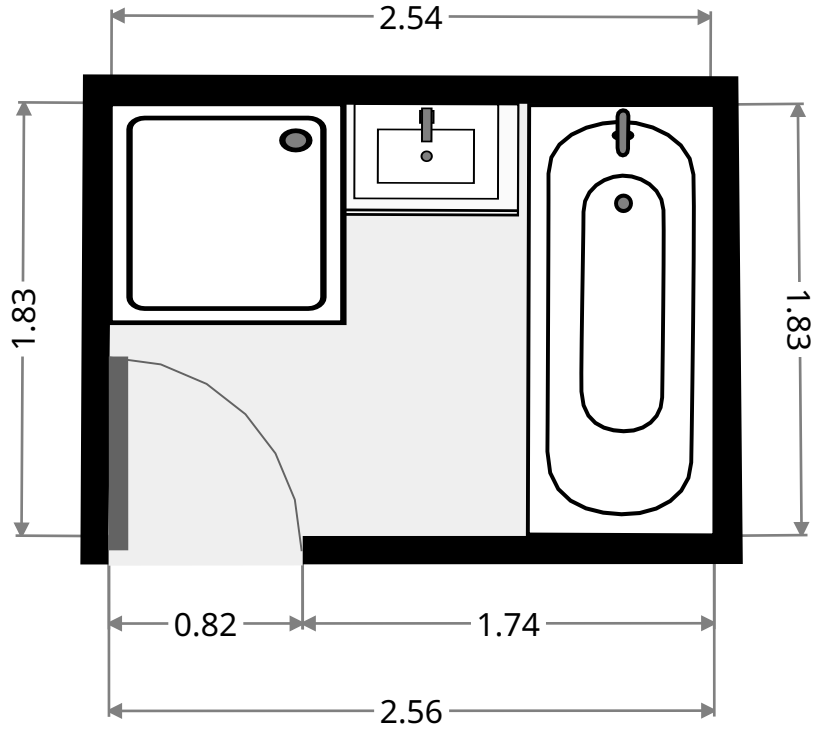
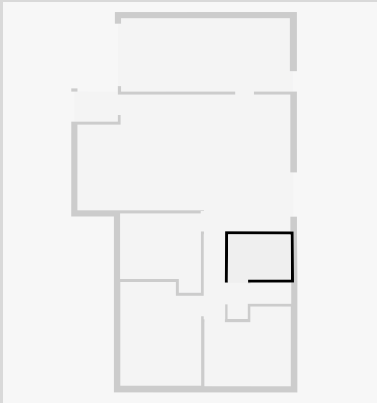

Width: 1.10 m
 Length: 1.64 m
 Area: 1.80 m²
 Perimeter: 5.48 m

