

3 Phyllis Street

SUBMITTED BY

Ray White Rockhampton Casey
stockers@cqoz.com

CREATED ON

2022-05-16

Floors

2

▼ Ground Floor

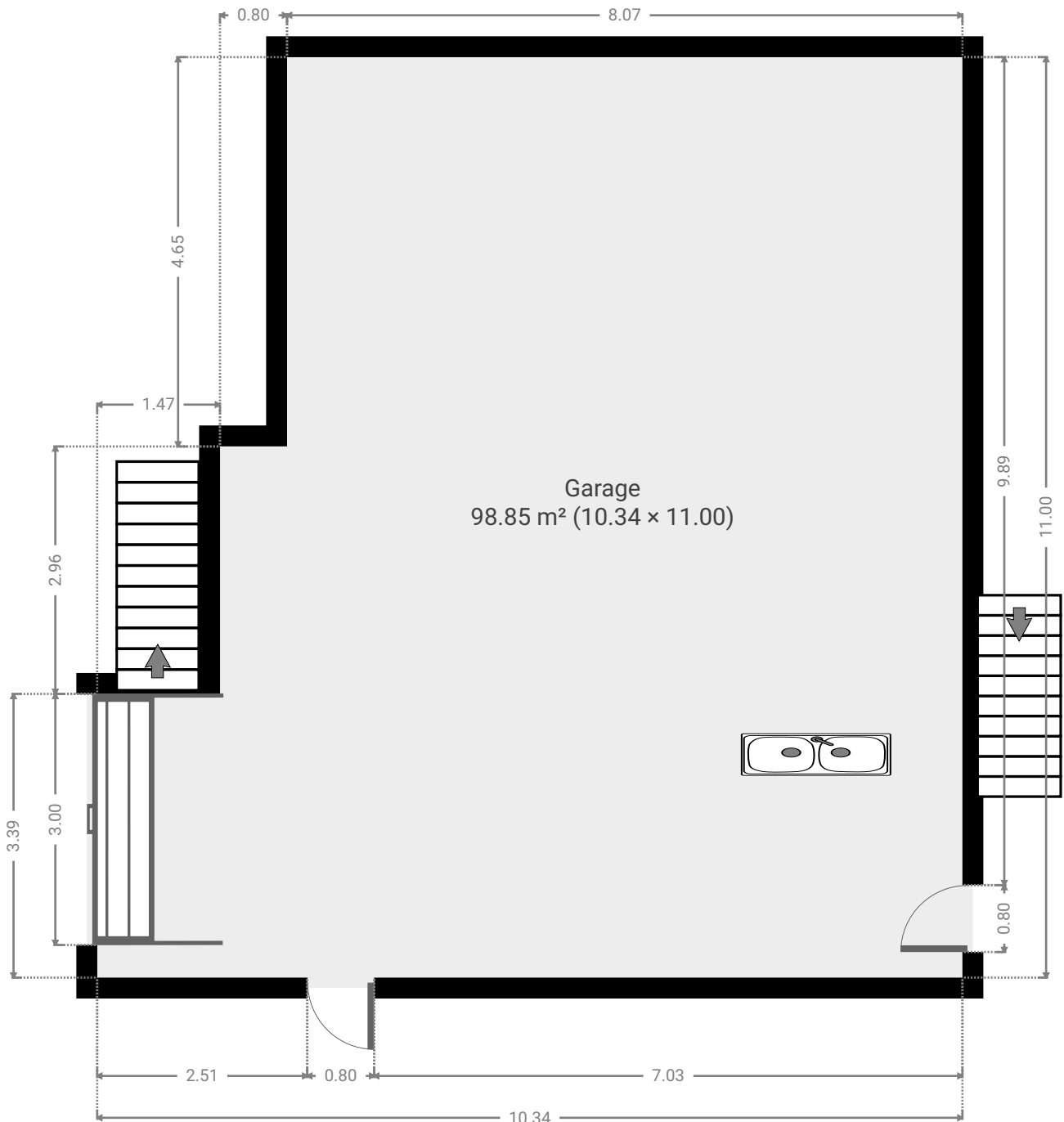

▼ Garage Ground Floor

WIDTH: 11.00 m • LENGTH: 10.34 m
AREA: 98.85 m² • PERIMETER: 42.68 m

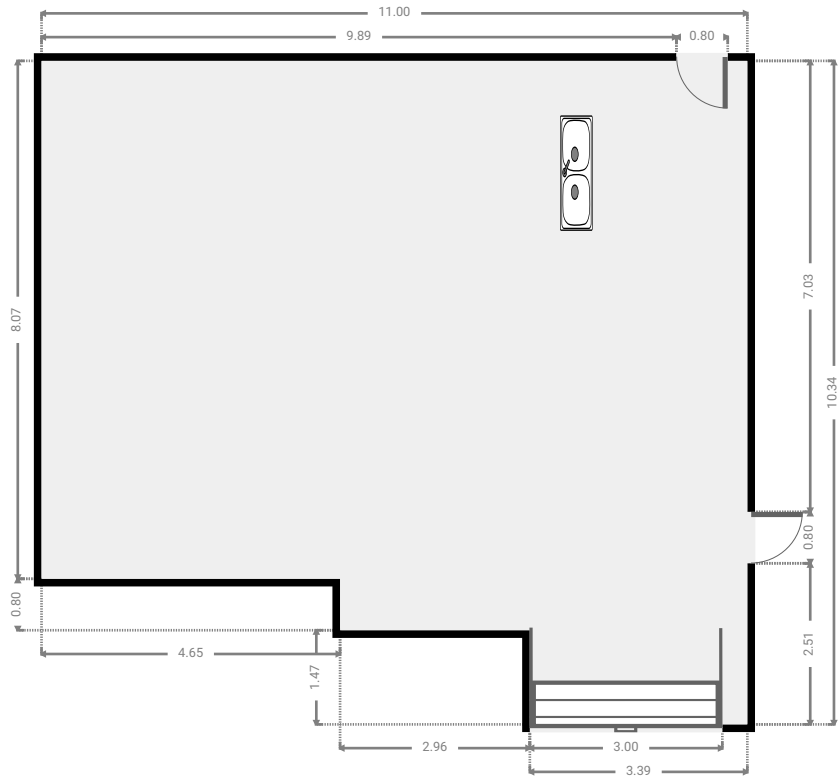
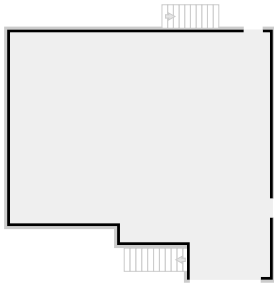

▼ 1st Floor

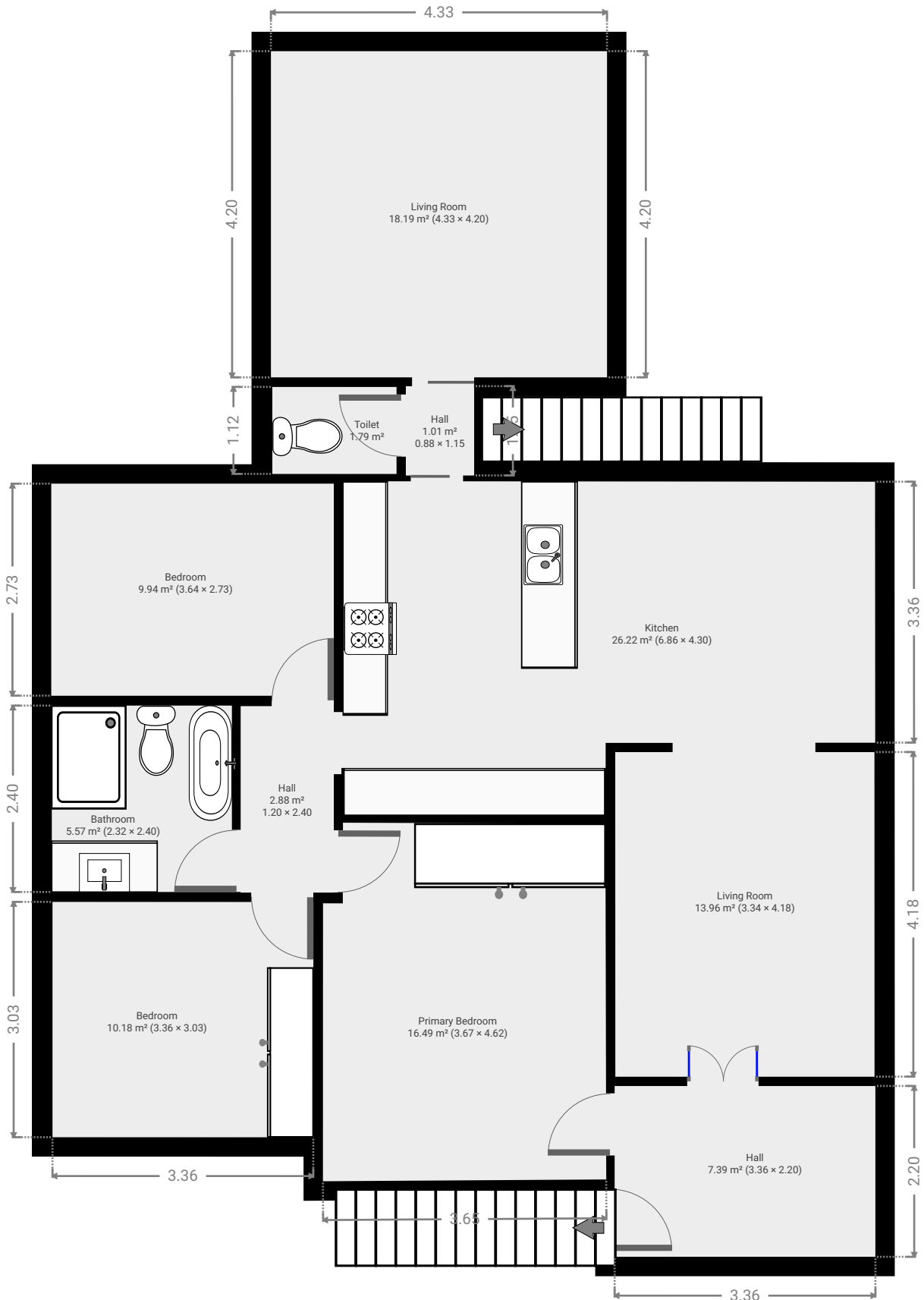

▼ **Bathroom**
1st Floor

WIDTH: 2.32 m • LENGTH: 2.40 m
AREA: 5.57 m² • PERIMETER: 9.44 m

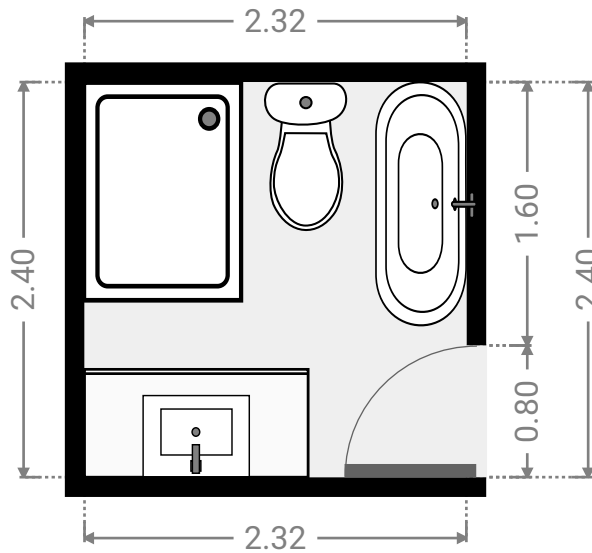
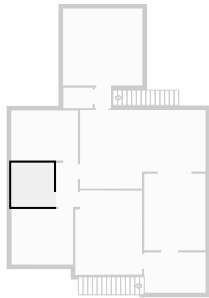

▼ **Bedroom**
1st Floor

WIDTH: 3.36 m • LENGTH: 3.03 m
AREA: 10.18 m² • PERIMETER: 12.78 m

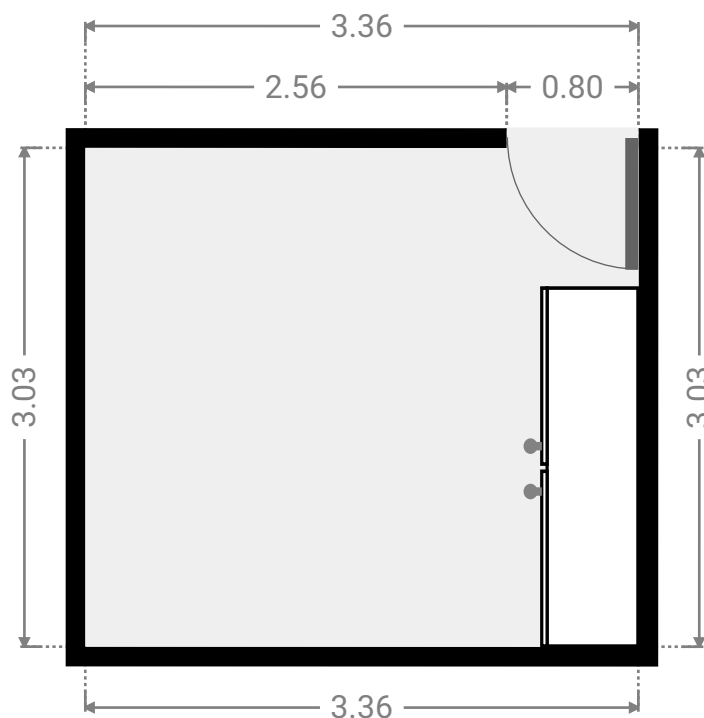
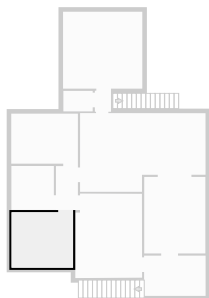

▼ Bedroom 1st Floor

WIDTH: 3.64 m • LENGTH: 2.73 m
AREA: 9.94 m² • PERIMETER: 12.74 m

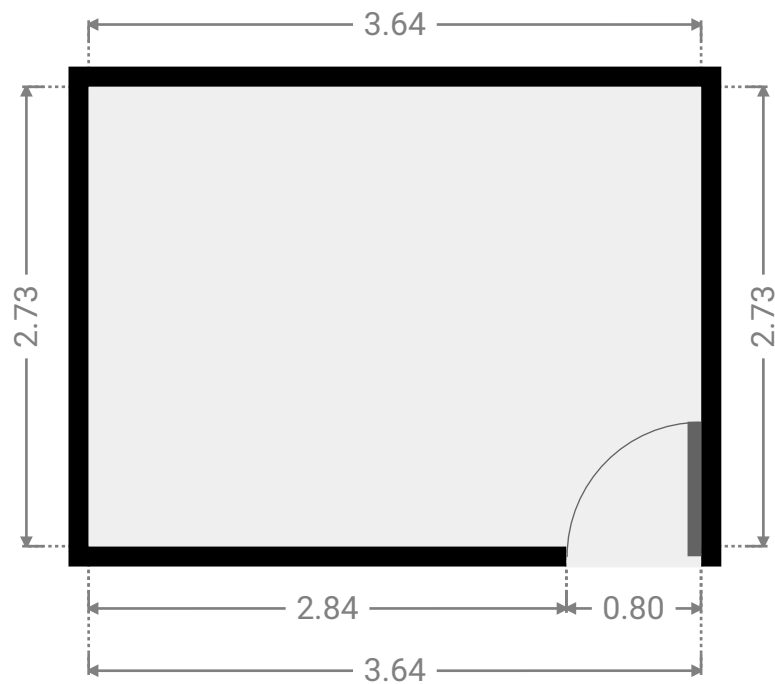
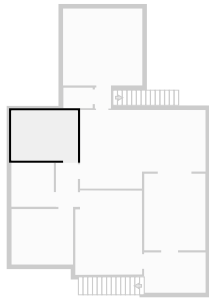

▼ Hall 1st Floor

WIDTH: 3.36 m • LENGTH: 2.20 m
AREA: 7.39 m² • PERIMETER: 11.12 m

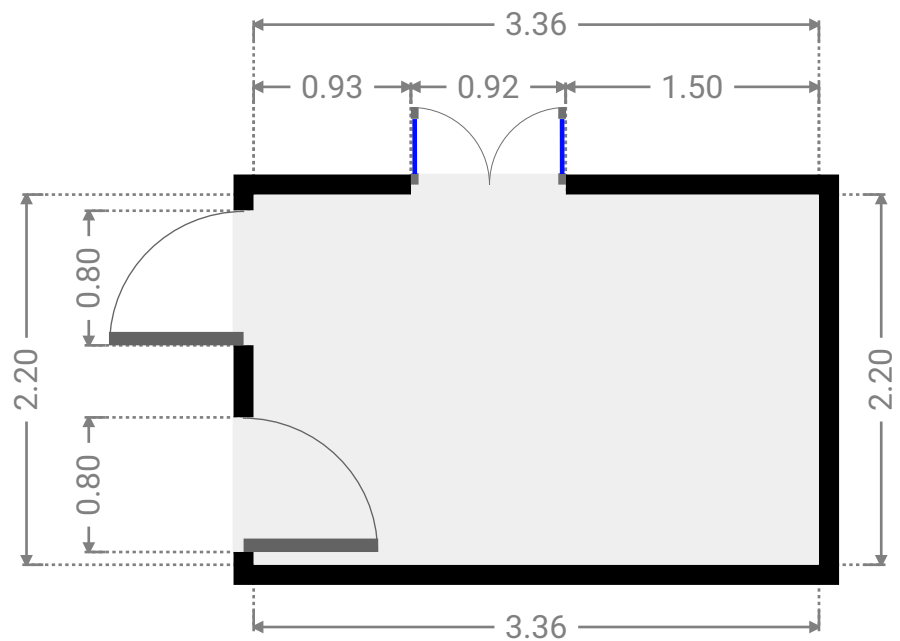
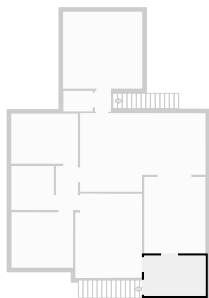

▼ **Hall**
1st Floor

WIDTH: 1.20 m • LENGTH: 2.40 m
AREA: 2.88 m² • PERIMETER: 7.20 m

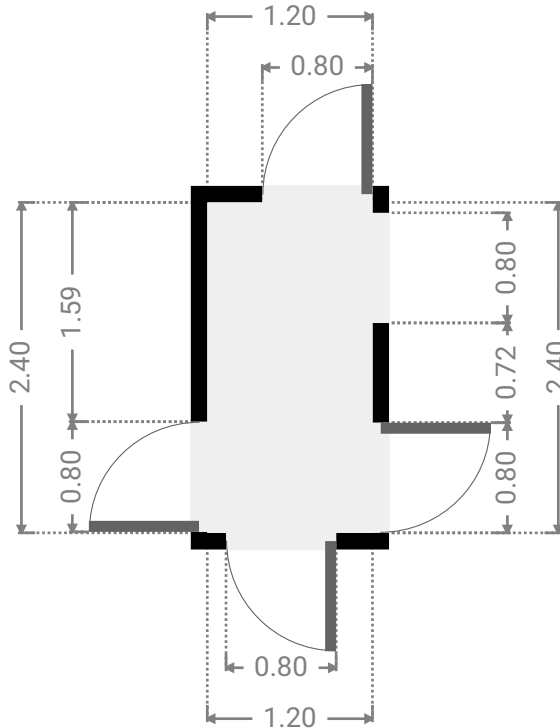
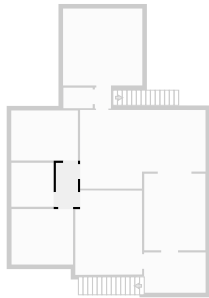

▼ **Hall**
1st Floor

WIDTH: 0.88 m • LENGTH: 1.15 m
AREA: 1.01 m² • PERIMETER: 4.06 m

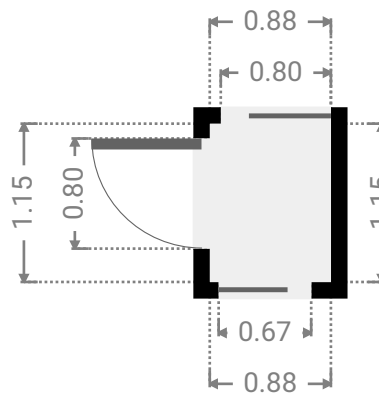
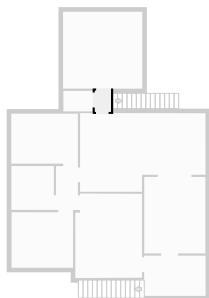

▼ **Kitchen**
1st Floor

WIDTH: 6.86 m • LENGTH: 4.30 m
AREA: 26.22 m² • PERIMETER: 22.30 m

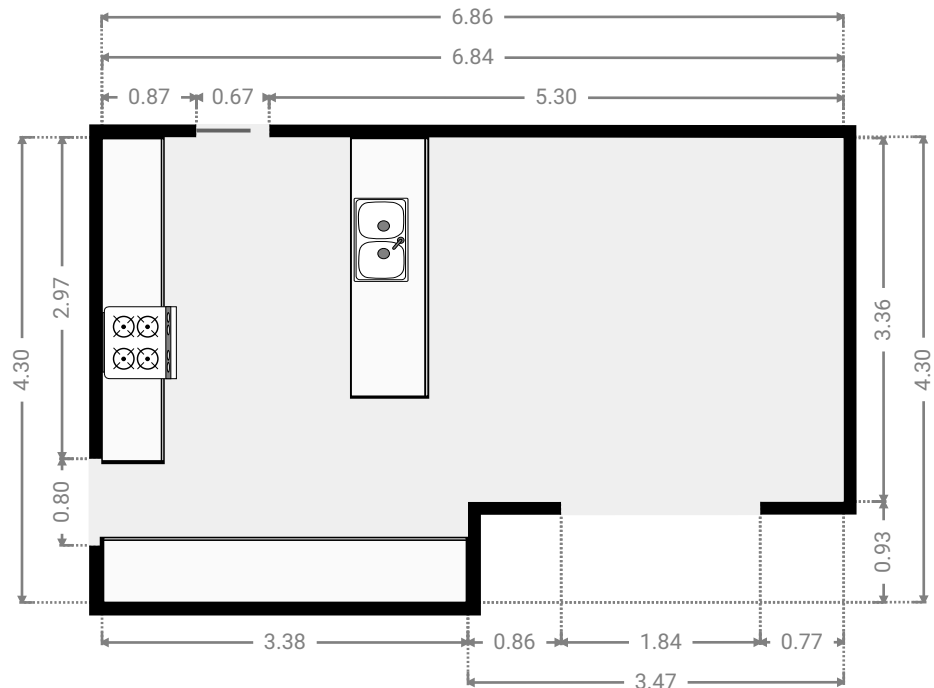
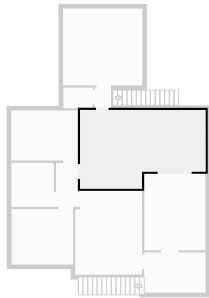

▼ **Living Room**
1st Floor

WIDTH: 3.34 m • LENGTH: 4.18 m
AREA: 13.96 m² • PERIMETER: 15.04 m

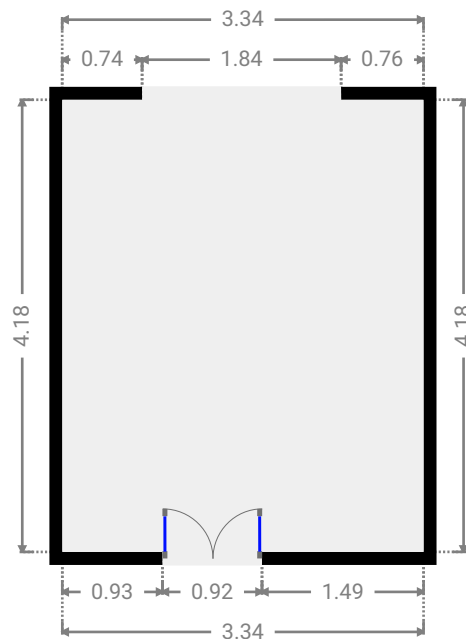
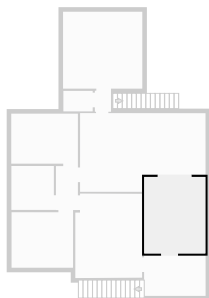

▼ **Living Room**
1st Floor

WIDTH: 4.33 m • LENGTH: 4.20 m
AREA: 18.19 m² • PERIMETER: 17.06 m

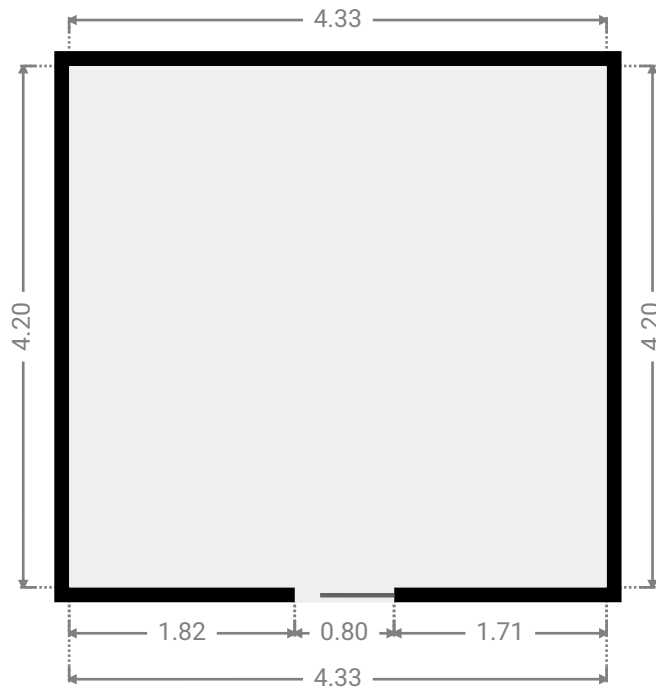
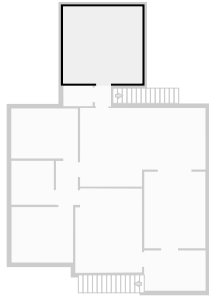

▼ **Primary Bedroom**
1st Floor

WIDTH: 3.67 m • LENGTH: 4.62 m
AREA: 16.49 m² • PERIMETER: 16.48 m

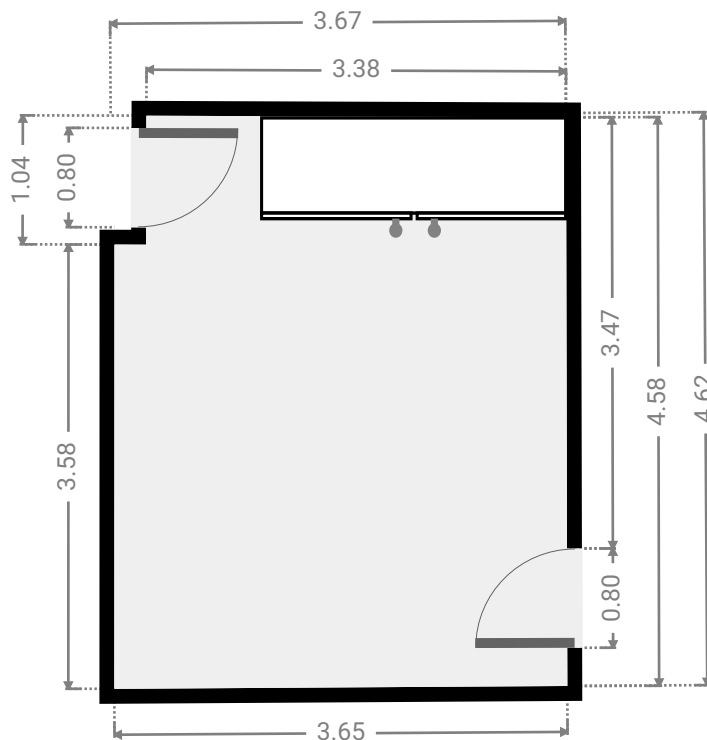
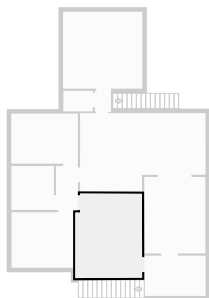

▼ Toilet
1st Floor

WIDTH: 1.60 m • LENGTH: 1.12 m
AREA: 1.79 m² • PERIMETER: 5.44 m

