

3/75 Edington Street

Created on
2021-06-08

Floors
2

▼ Ground Floor

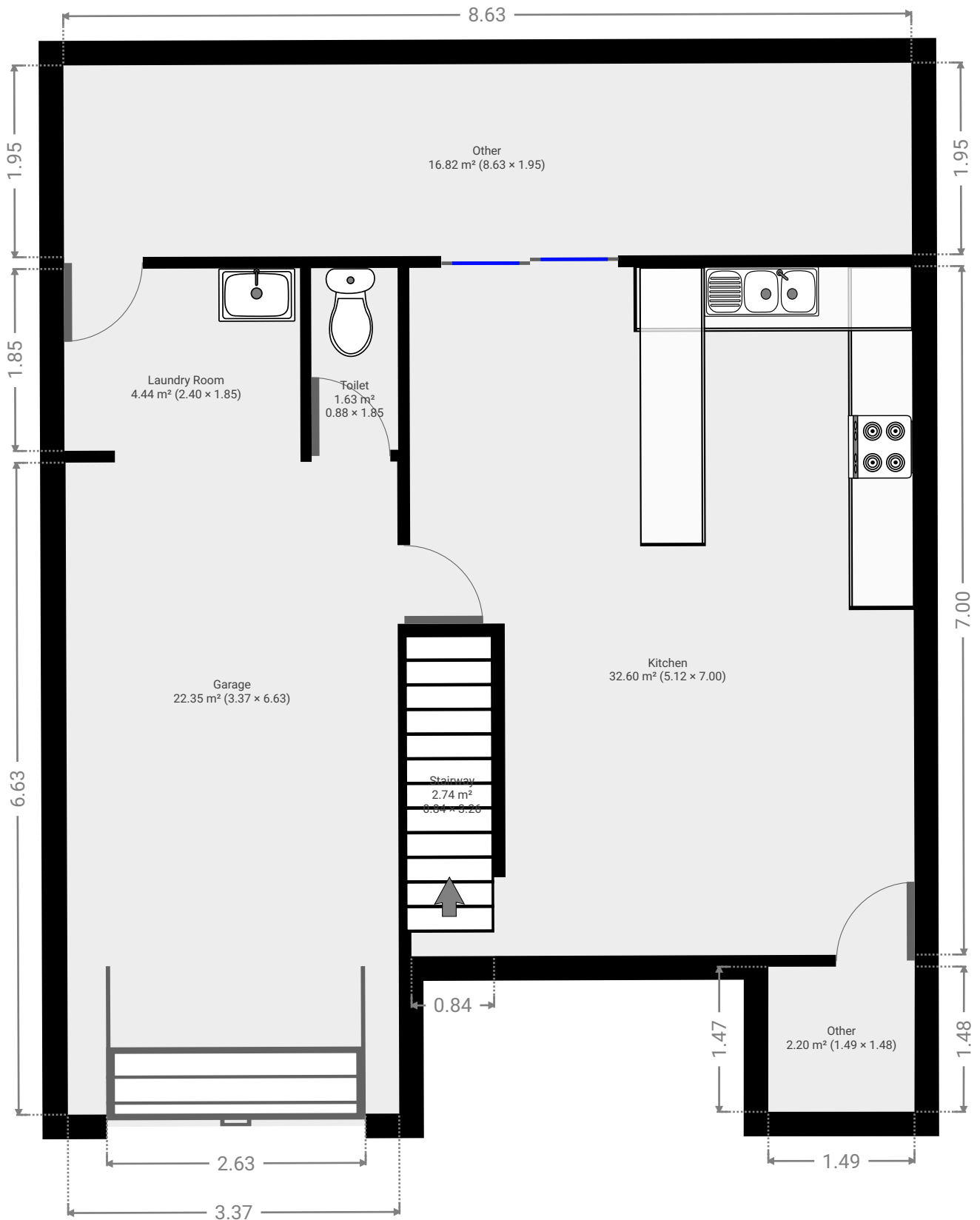

▼ **Kitchen**
Ground Floor

WIDTH: 7.00 m • LENGTH: 5.12 m
AREA: 32.60 m² • PERIMETER: 24.24 m

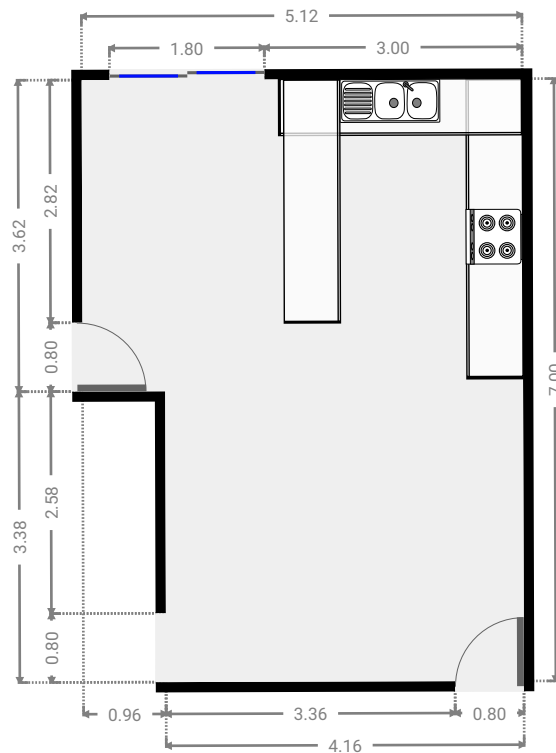
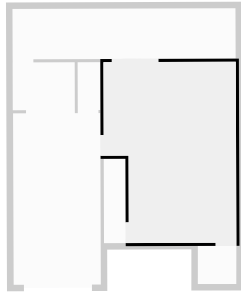

▼ **Stairway**
Ground Floor

WIDTH: 3.26 m • LENGTH: 0.84 m
AREA: 2.74 m² • PERIMETER: 8.20 m

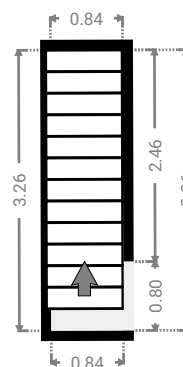
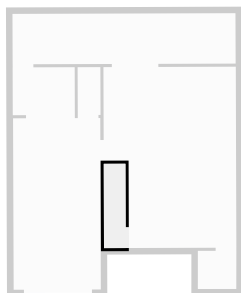

▼ **Toilet**
Ground Floor

WIDTH: 1.85 m • LENGTH: 0.88 m
AREA: 1.63 m² • PERIMETER: 5.46 m

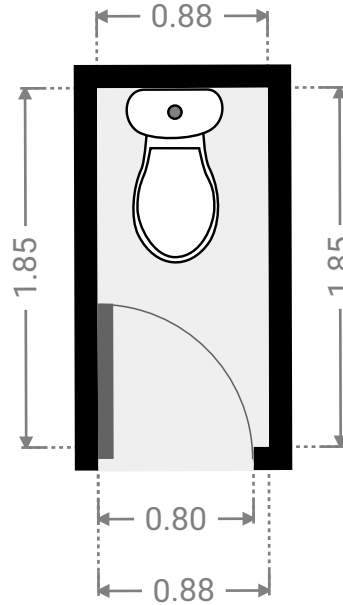
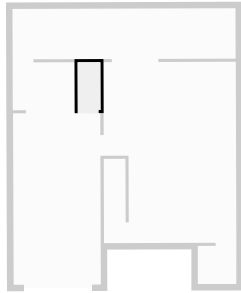

▼ **Laundry Room**
Ground Floor

WIDTH: 1.85 m • LENGTH: 2.40 m
AREA: 4.44 m² • PERIMETER: 8.50 m

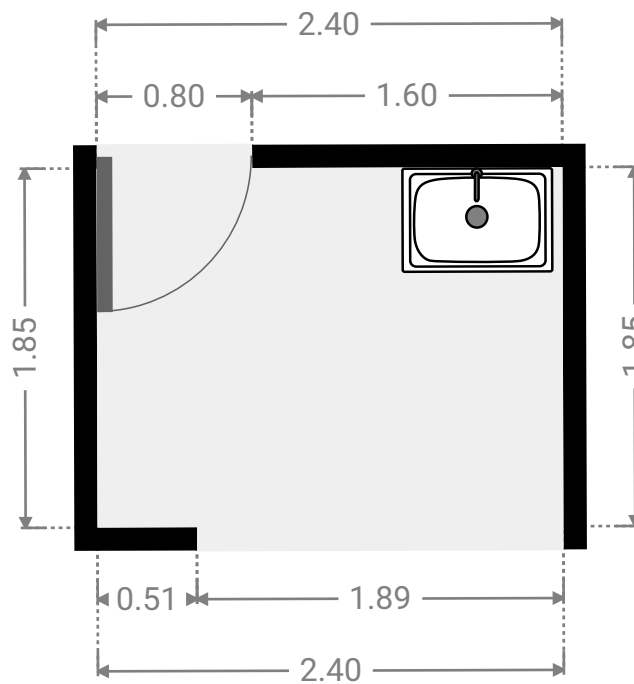
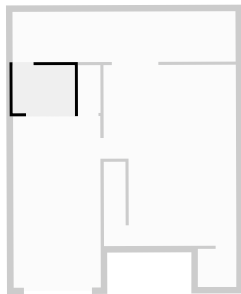

▼ **Garage**
Ground Floor

WIDTH: 6.63 m • LENGTH: 3.37 m
AREA: 22.35 m² • PERIMETER: 20.00 m

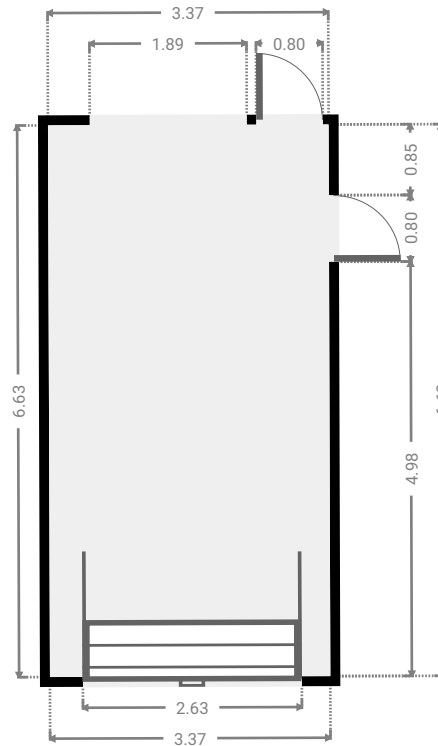
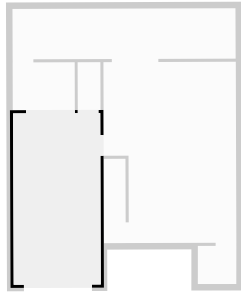

▼ **Other**
Ground Floor

WIDTH: 1.95 m • LENGTH: 8.63 m
AREA: 16.82 m² • PERIMETER: 21.15 m

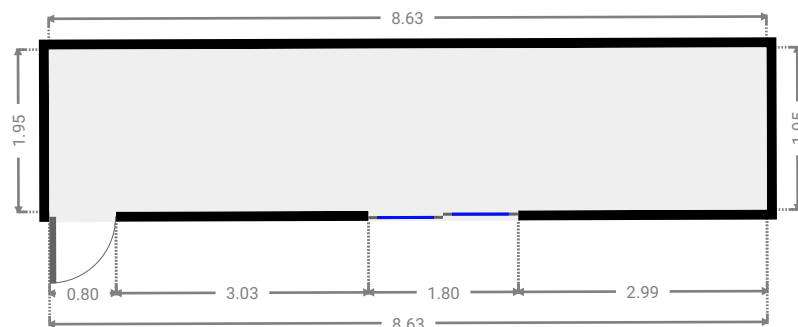
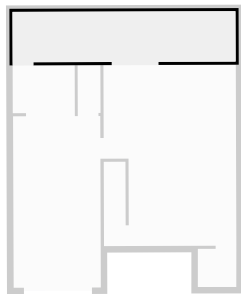

▼ Other
Ground Floor

WIDTH: 1.49 m • LENGTH: 1.48 m
AREA: 2.20 m² • PERIMETER: 5.93 m

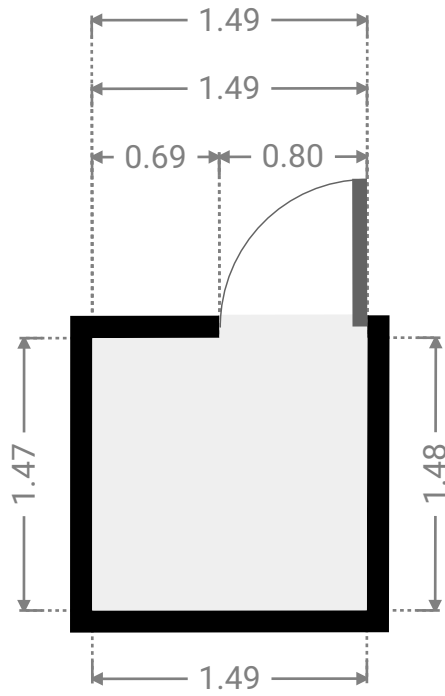
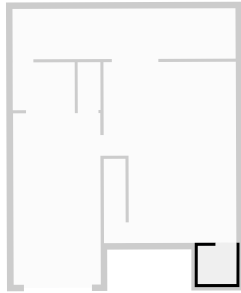

▼ 1st Floor

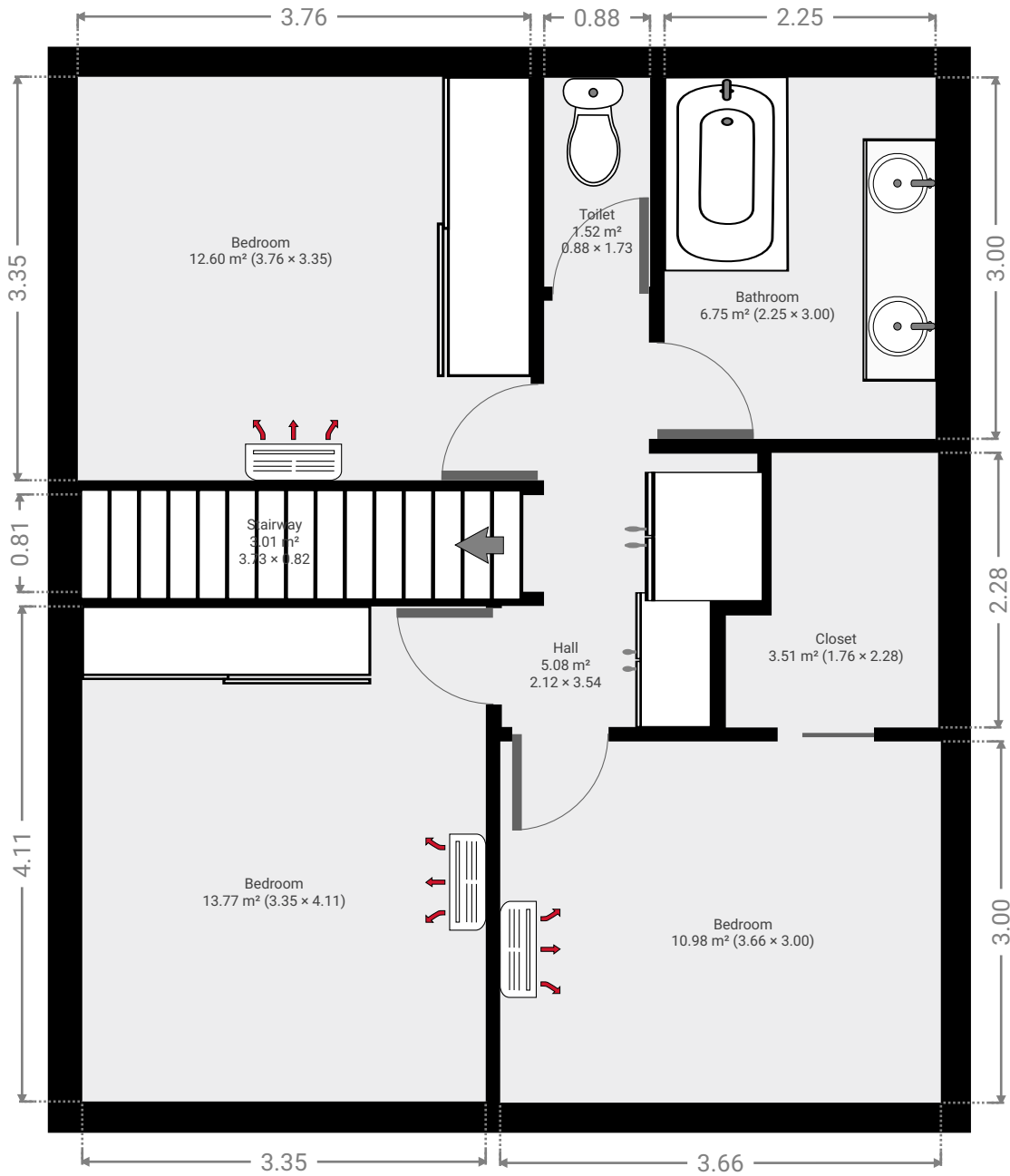

▼ **Bedroom**
1st Floor

WIDTH: 4.11 m • LENGTH: 3.35 m
AREA: 13.77 m² • PERIMETER: 14.92 m

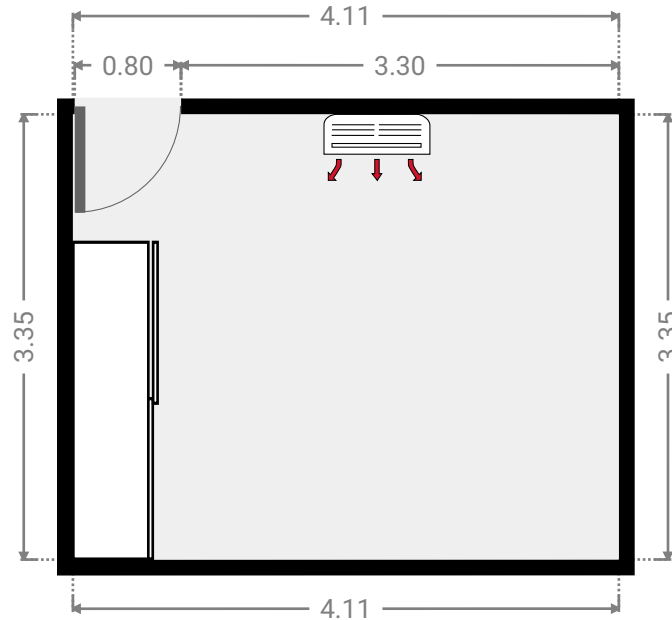
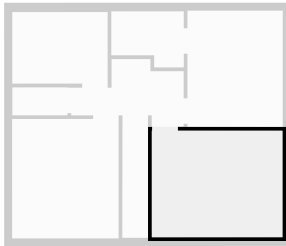

▼ **Hall**
1st Floor

WIDTH: 3.54 m • LENGTH: 2.12 m
AREA: 5.08 m² • PERIMETER: 11.32 m

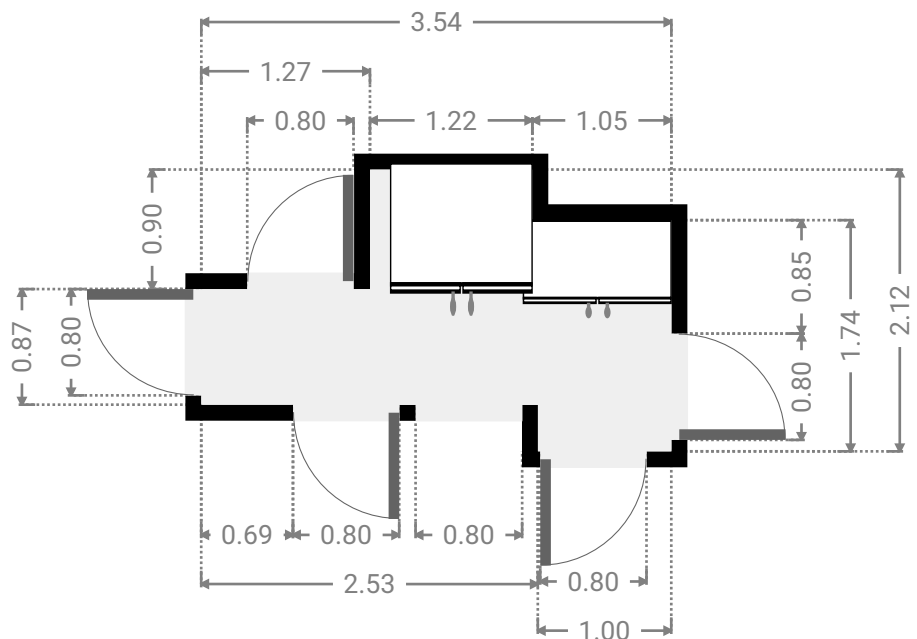
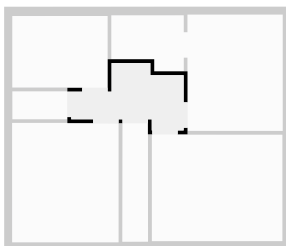

▼ **Bedroom**
1st Floor

WIDTH: 3.00 m • LENGTH: 3.66 m
AREA: 10.98 m² • PERIMETER: 13.32 m

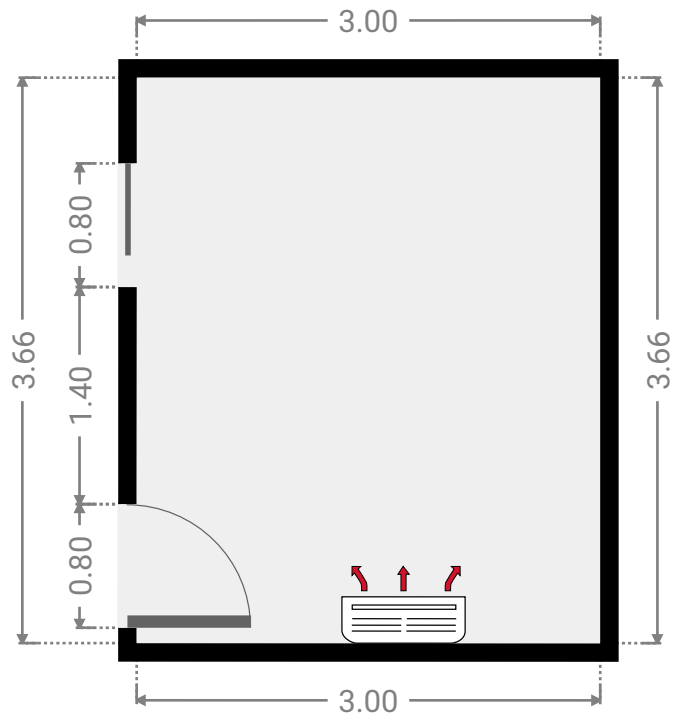
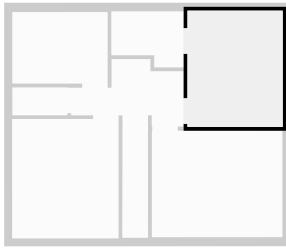

▼ **Closet**
1st Floor

WIDTH: 2.28 m • LENGTH: 1.76 m
AREA: 3.51 m² • PERIMETER: 8.09 m

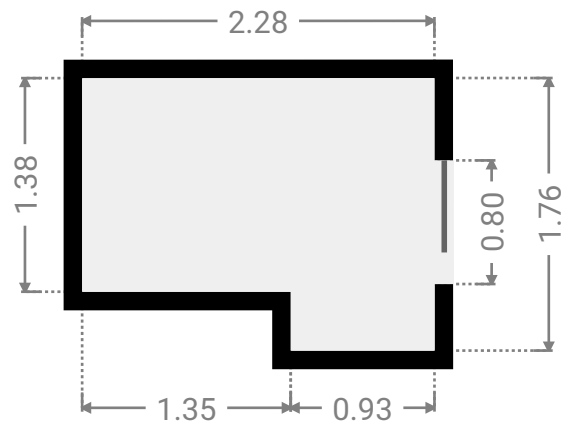
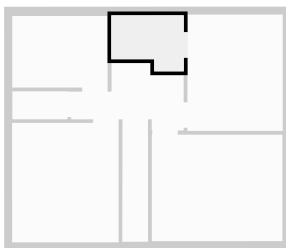

▼ **Bathroom**
1st Floor

WIDTH: 3.00 m • LENGTH: 2.25 m
AREA: 6.75 m² • PERIMETER: 10.50 m

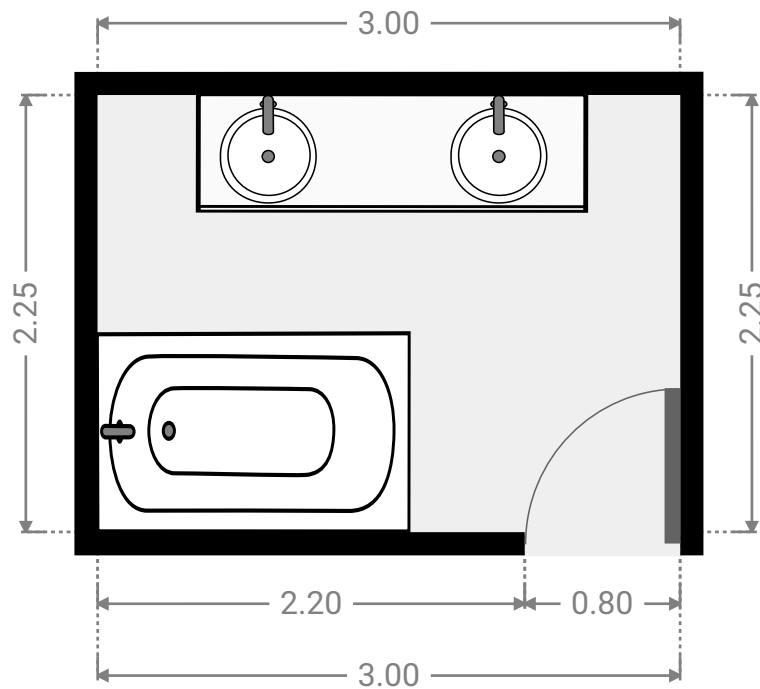
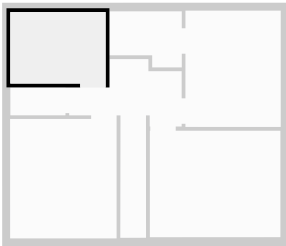

▼ **Toilet**
1st Floor

WIDTH: 1.73 m • LENGTH: 0.88 m
AREA: 1.52 m² • PERIMETER: 5.23 m

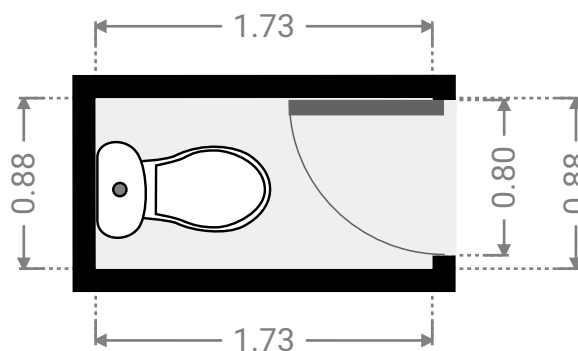
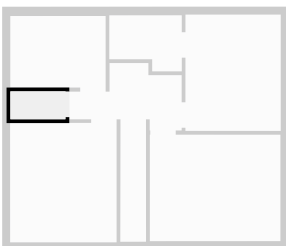

▼ **Bedroom**
1st Floor

WIDTH: 3.35 m • LENGTH: 3.76 m
AREA: 12.60 m² • PERIMETER: 14.22 m

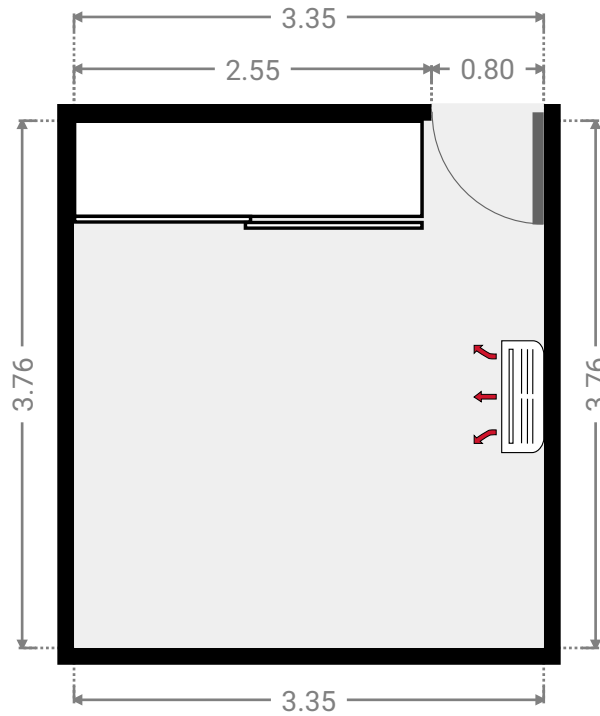
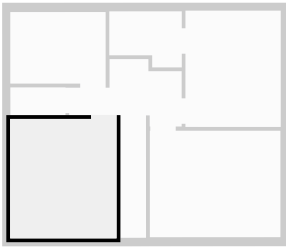

▼ **Stairway**
1st Floor

WIDTH: 0.82 m • LENGTH: 3.73 m
AREA: 3.01 m² • PERIMETER: 9.08 m

