

3/47 Denison Street

SUBMITTED BY

Ray White Rockhampton Casey
stockers@cqoz.com

CREATED ON

2021-06-29

Floors

1

▼ Ground Floor

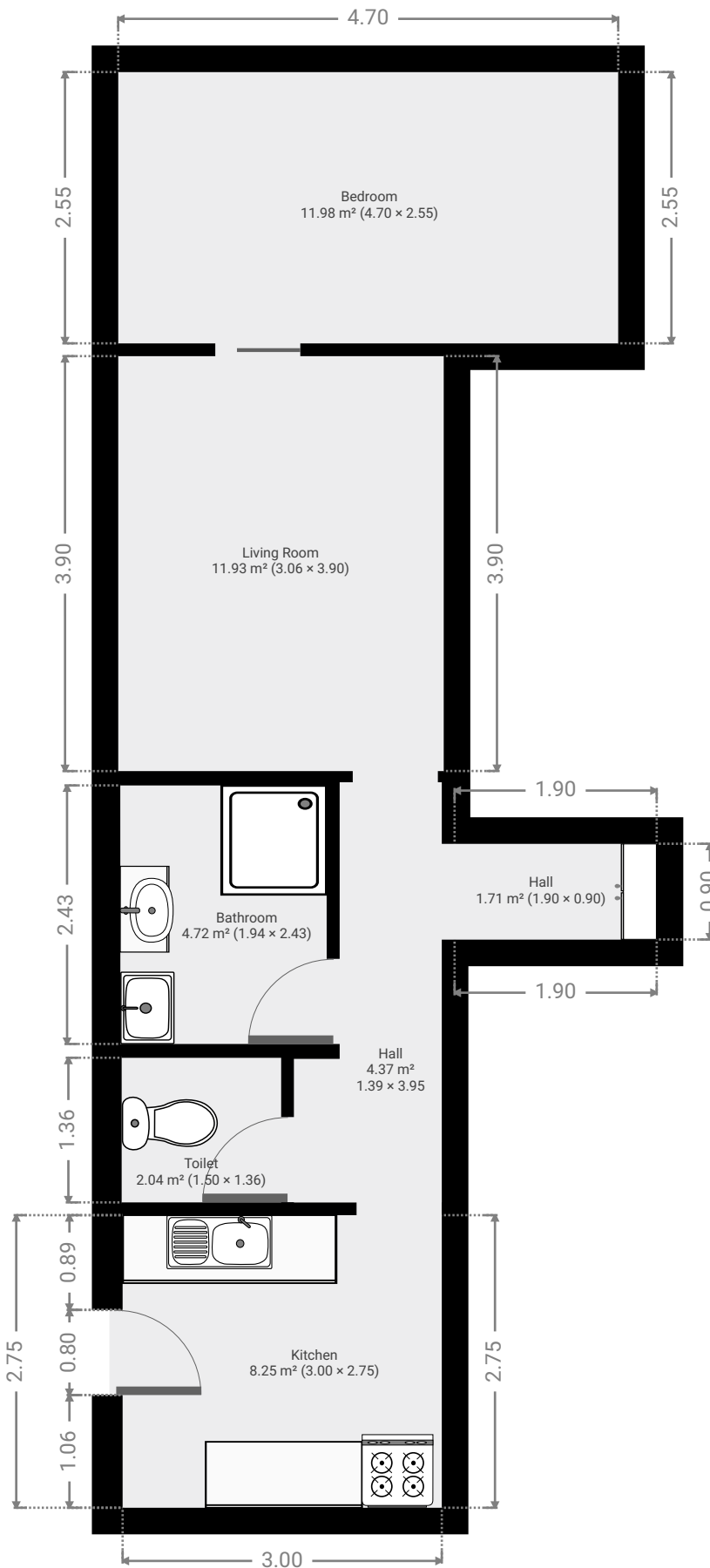

FLOORS: 1

▼ Kitchen
Ground Floor

WIDTH: 3.00 m • LENGTH: 2.75 m
AREA: 8.25 m² • PERIMETER: 11.50 m

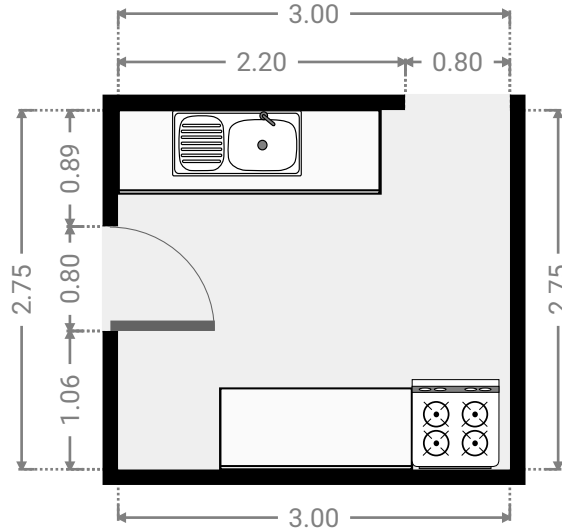

▼ Hall
Ground Floor

WIDTH: 1.39 m • LENGTH: 3.95 m
AREA: 4.37 m² • PERIMETER: 10.68 m

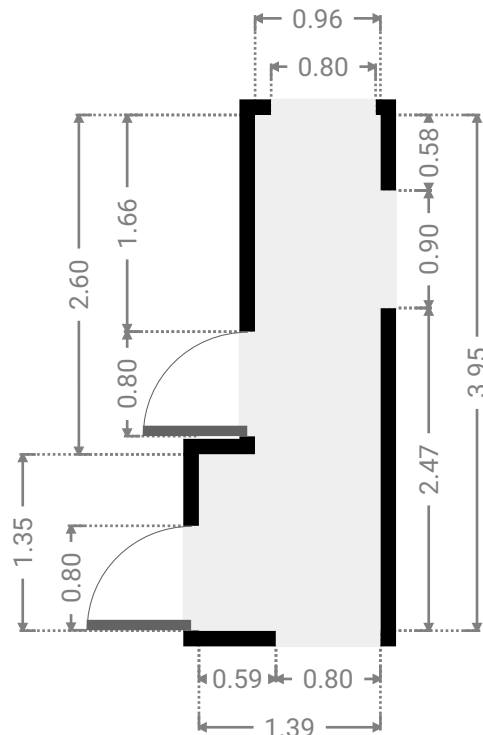
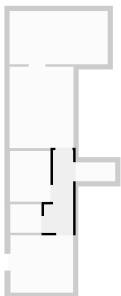

FLOORS: 1

▼ Toilet
Ground Floor

WIDTH: 1.50 m • LENGTH: 1.36 m
AREA: 2.04 m² • PERIMETER: 5.72 m

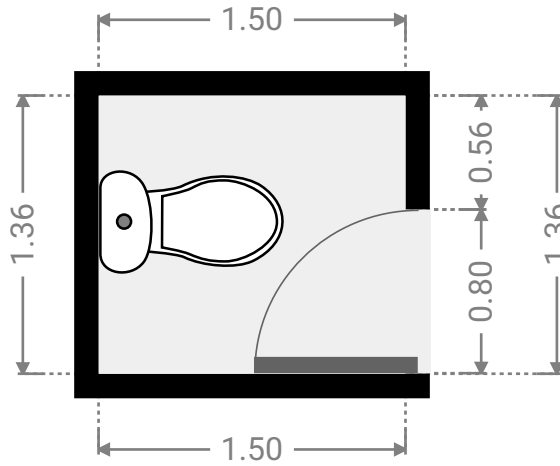
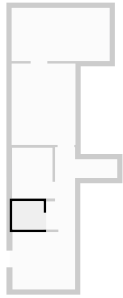

▼ Bathroom
Ground Floor

WIDTH: 1.94 m • LENGTH: 2.43 m
AREA: 4.72 m² • PERIMETER: 8.74 m

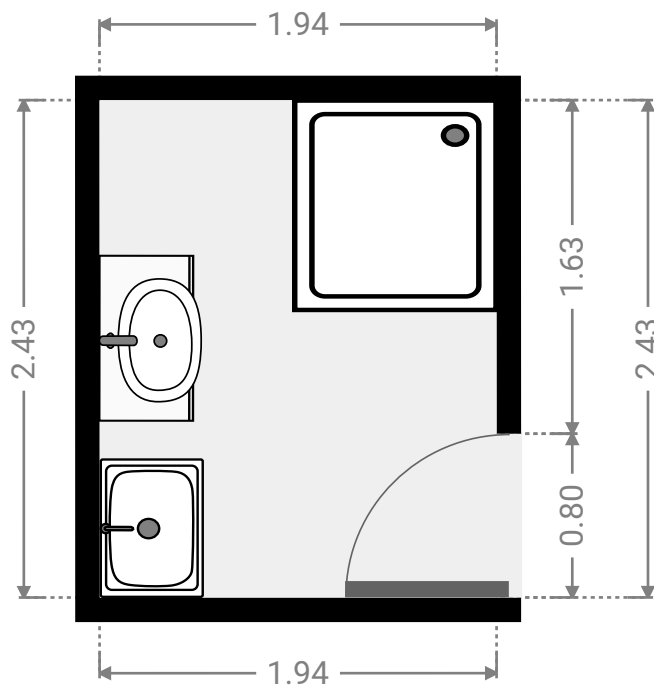
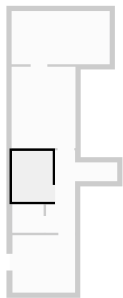

FLOORS: 1

▼ **Living Room**
Ground Floor

WIDTH: 3.06 m • LENGTH: 3.90 m
AREA: 11.93 m² • PERIMETER: 13.92 m

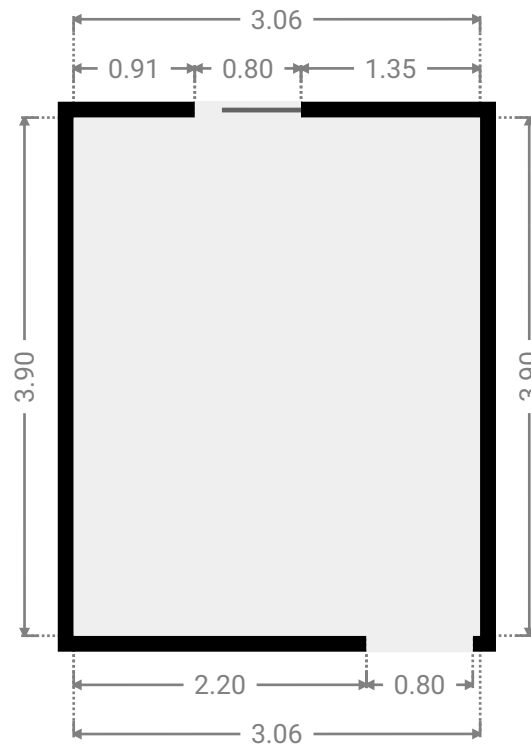
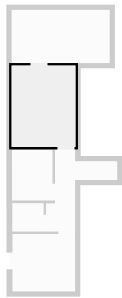

▼ **Bedroom**
Ground Floor

WIDTH: 4.70 m • LENGTH: 2.55 m
AREA: 11.98 m² • PERIMETER: 14.50 m

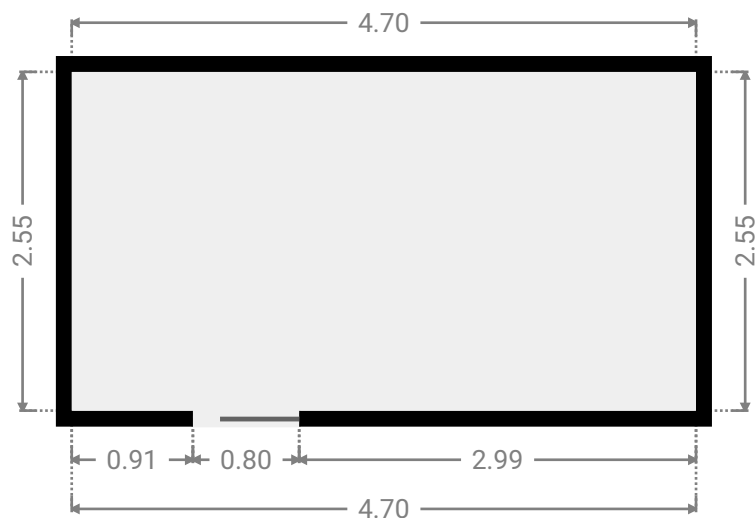
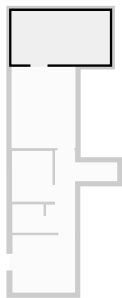

▼ **Hall**
Ground Floor

WIDTH: 1.90 m • LENGTH: 0.90 m
AREA: 1.71 m² • PERIMETER: 5.60 m

