

2A Buxton Drive

Created on
2021-07-15

Floors
1



▼ Ground Floor

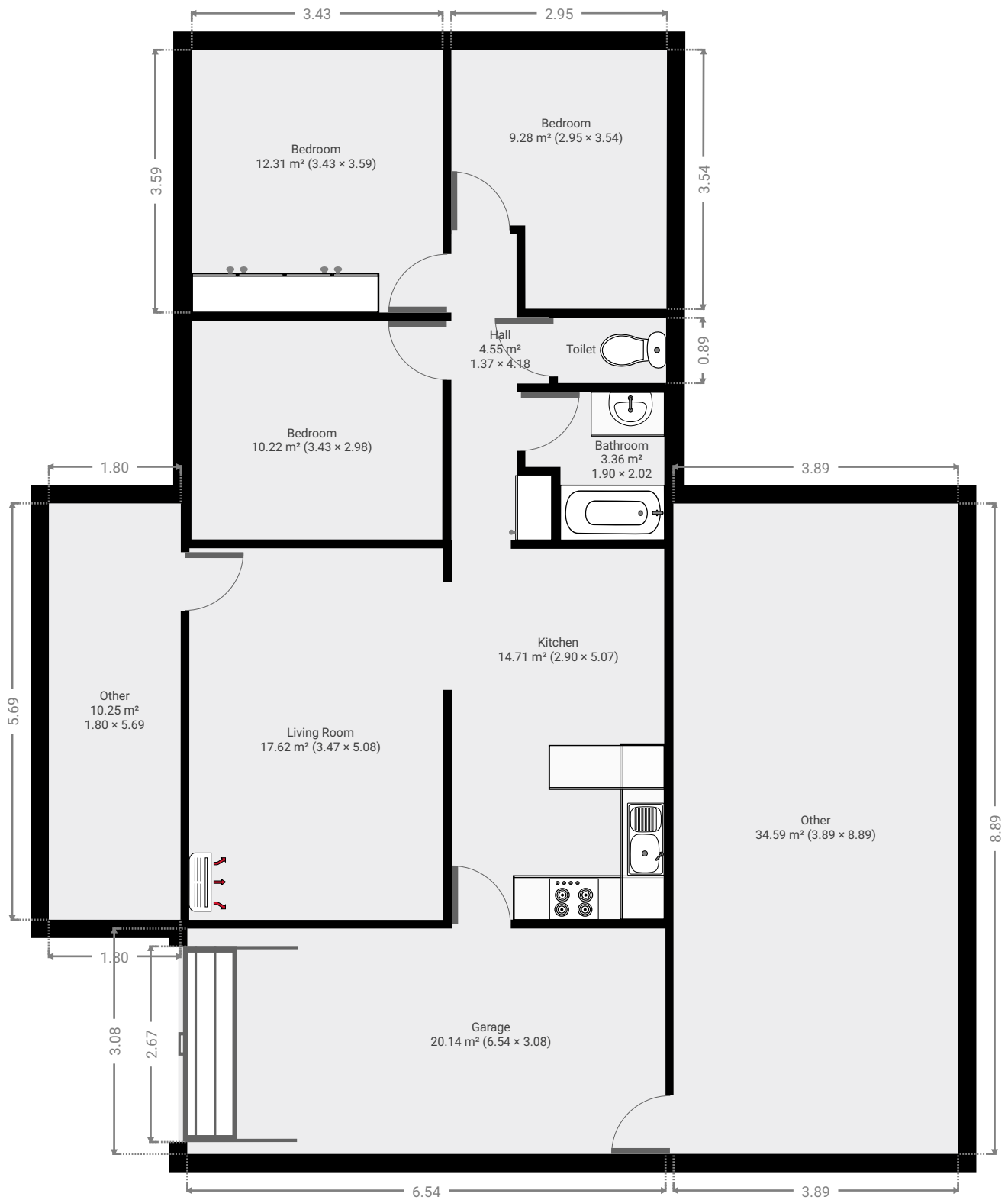

▼ Living Room
Ground Floor

WIDTH: 5.08 m • LENGTH: 3.47 m
AREA: 17.62 m² • PERIMETER: 17.10 m

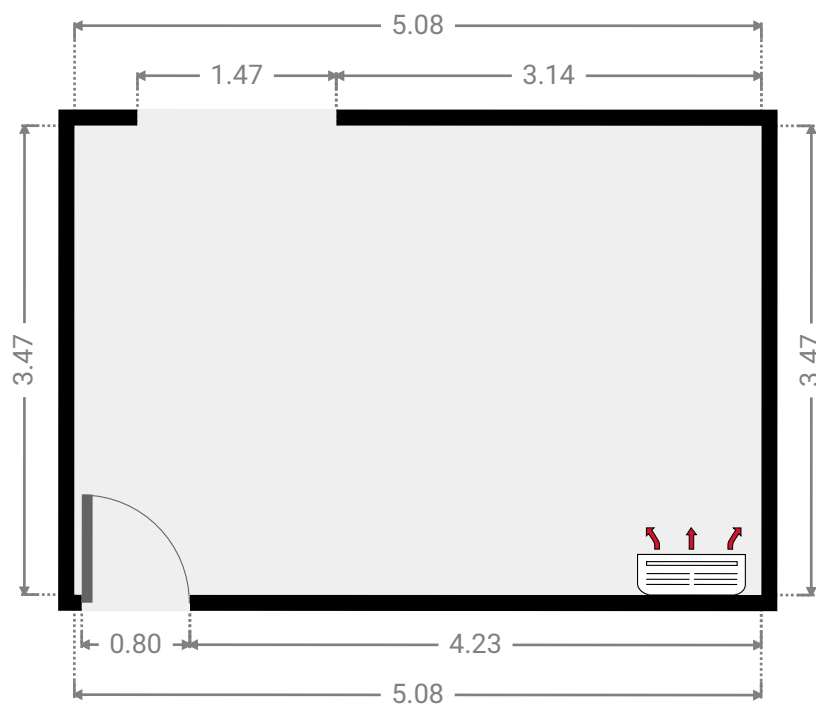
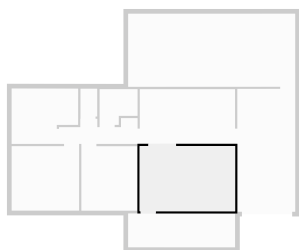

▼ Kitchen
Ground Floor

WIDTH: 5.07 m • LENGTH: 2.90 m
AREA: 14.71 m² • PERIMETER: 15.94 m

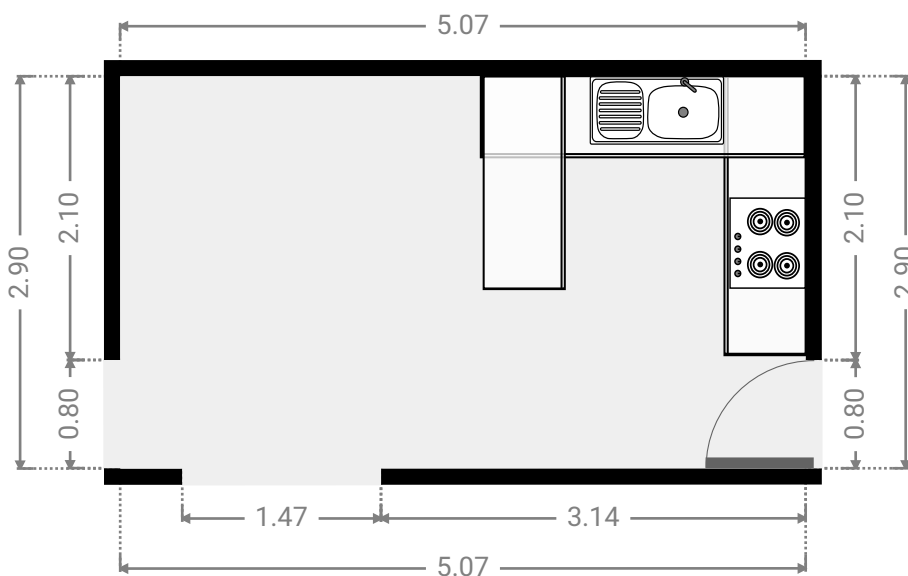
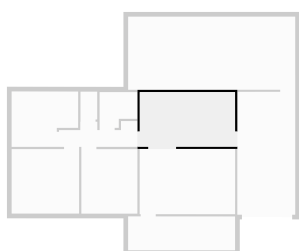

▼ **Hall**
Ground Floor

WIDTH: 4.18 m • LENGTH: 1.37 m
AREA: 4.55 m² • PERIMETER: 12.00 m

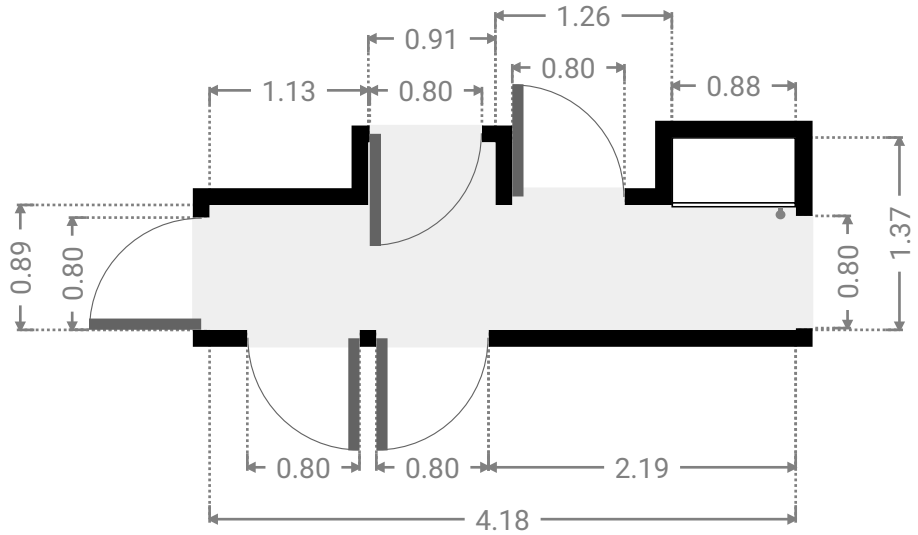
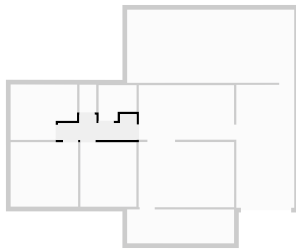

▼ **Bathroom**
Ground Floor

WIDTH: 2.02 m • LENGTH: 1.90 m
AREA: 3.36 m² • PERIMETER: 7.84 m

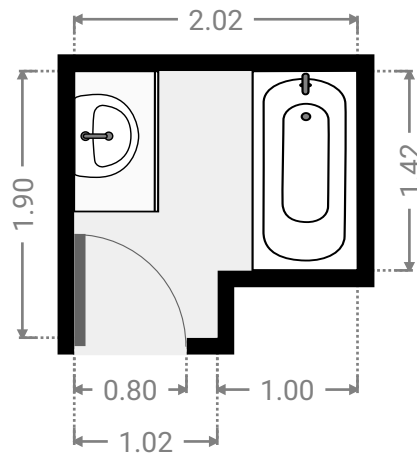
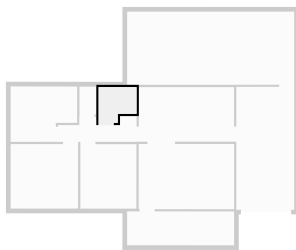

▼ Toilet
Ground Floor

WIDTH: 0.89 m • LENGTH: 1.48 m
AREA: 1.32 m² • PERIMETER: 4.74 m

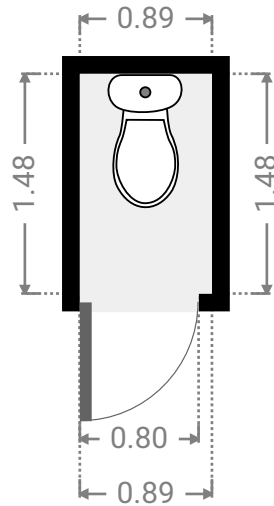
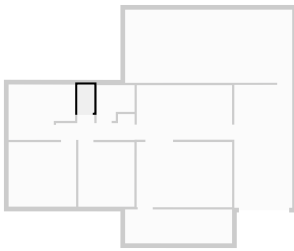

▼ Bedroom
Ground Floor

WIDTH: 2.98 m • LENGTH: 3.43 m
AREA: 10.22 m² • PERIMETER: 12.82 m

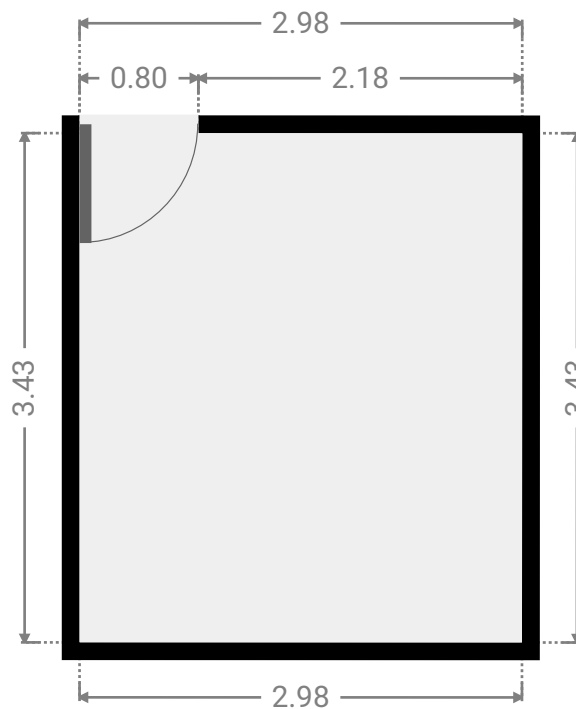
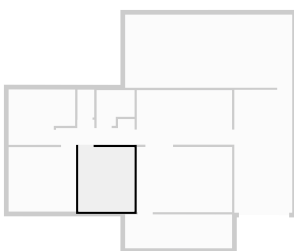

▼ **Bedroom**
Ground Floor

WIDTH: 3.59 m • LENGTH: 3.43 m
AREA: 12.31 m² • PERIMETER: 14.04 m

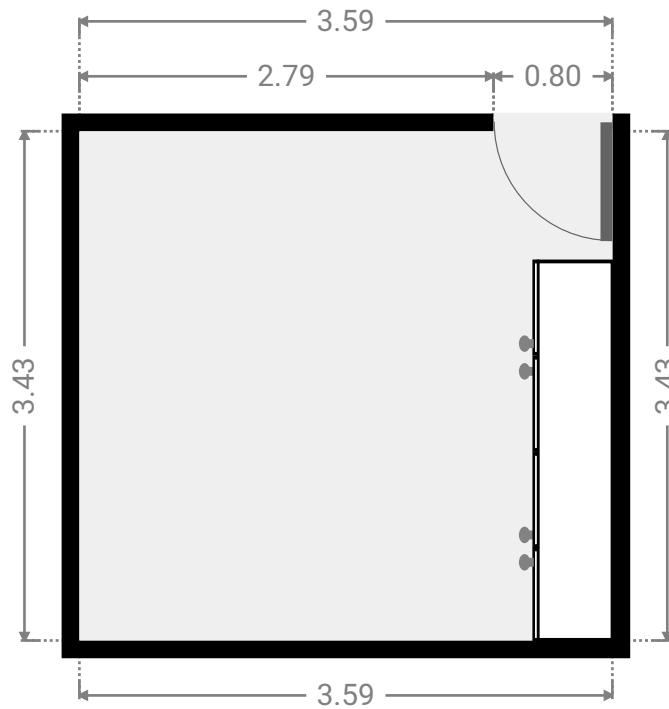
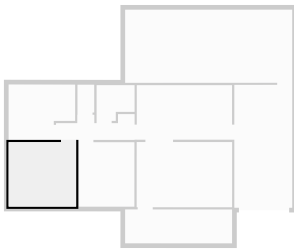

▼ **Bedroom**
Ground Floor

WIDTH: 3.54 m • LENGTH: 2.95 m
AREA: 9.28 m² • PERIMETER: 12.97 m

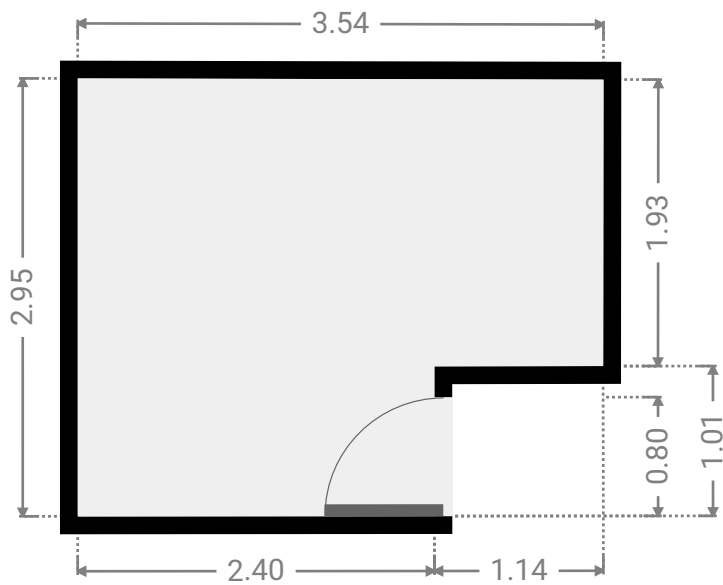
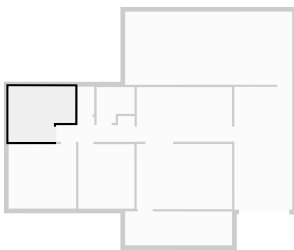

▼ **Garage**
Ground Floor

WIDTH: 3.08 m • LENGTH: 6.54 m
AREA: 20.14 m² • PERIMETER: 19.24 m

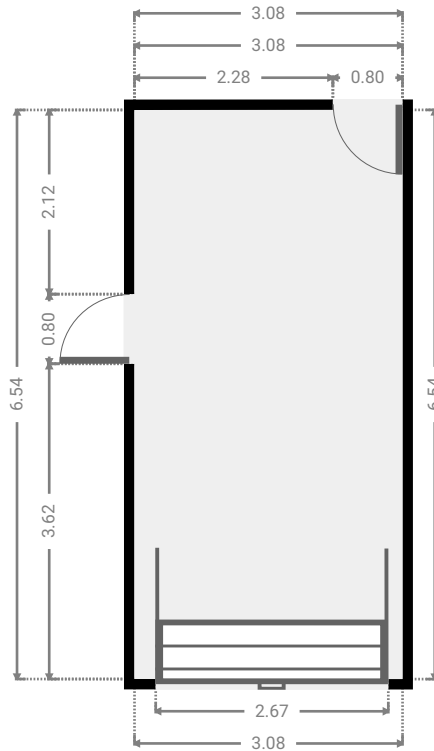
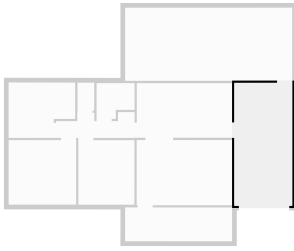

▼ **Other**
Ground Floor

WIDTH: 8.89 m • LENGTH: 3.89 m
AREA: 34.59 m² • PERIMETER: 25.56 m

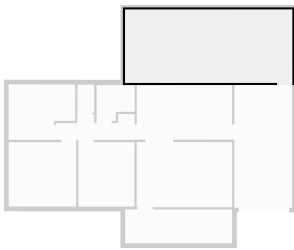

▼ Other
Ground Floor

WIDTH: 5.69 m • LENGTH: 1.80 m
AREA: 10.25 m² • PERIMETER: 14.99 m

