

# 293 Hook Street

**SUBMITTED BY**  
Ray White Rockhampton Casey  
stockers@cqoz.com

---

**CREATED ON**  
2021-12-06

---

**Floors**  
1

---

▼ Ground Floor



THIS FLOORPLAN IS PROVIDED WITHOUT WARRANTY OF ANY KIND. SENSOPIA DISCLAIMS ANY WARRANTY INCLUDING, WITHOUT LIMITATION, SATISFACTORY QUALITY OR ACCURACY OF DIMENSIONS.

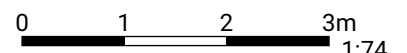

▼ Living Room  
Ground Floor

WIDTH: 6.40 m • LENGTH: 2.88 m  
AREA: 18.43 m<sup>2</sup> • PERIMETER: 18.56 m

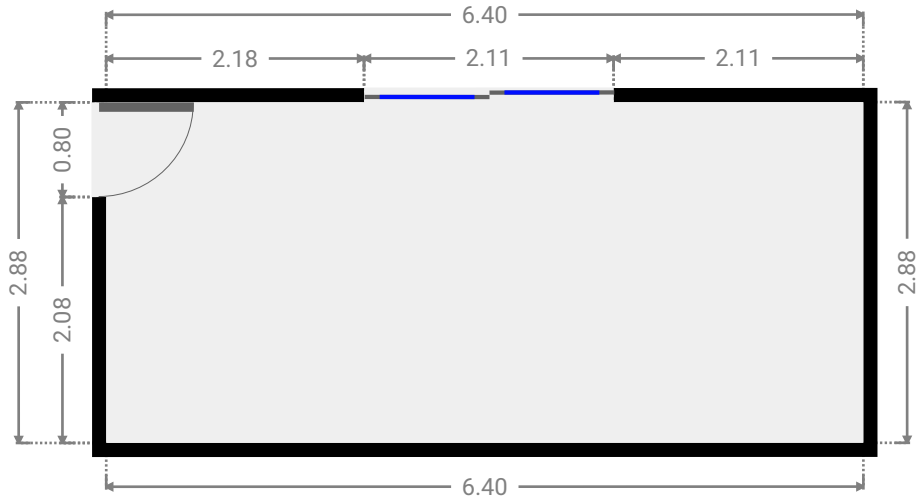
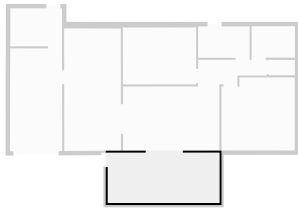

▼ Living Room  
Ground Floor

WIDTH: 5.52 m • LENGTH: 3.68 m  
AREA: 20.32 m<sup>2</sup> • PERIMETER: 18.40 m

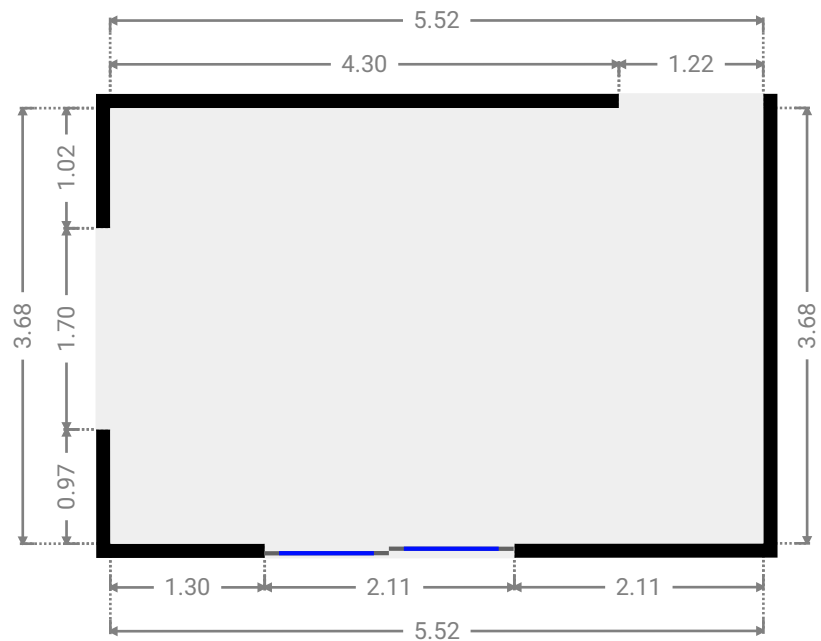
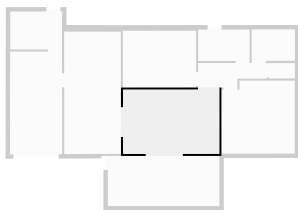

▼ **Dining Room**  
Ground Floor

WIDTH: 3.28 m • LENGTH: 7.03 m  
AREA: 22.81 m<sup>2</sup> • PERIMETER: 20.53 m

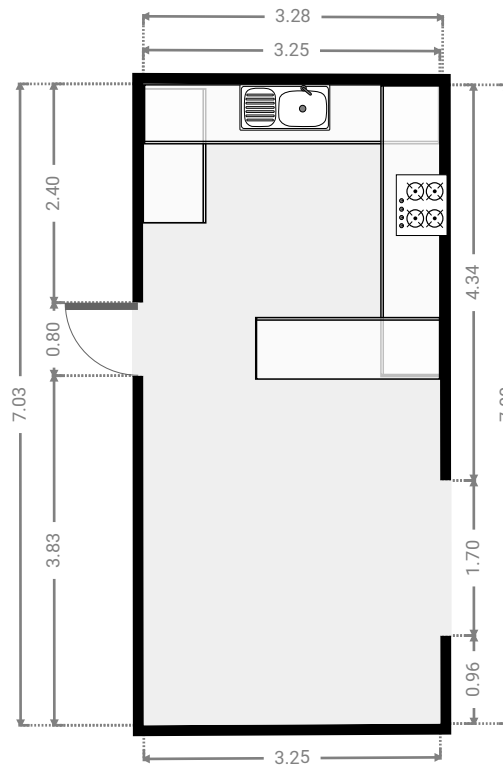
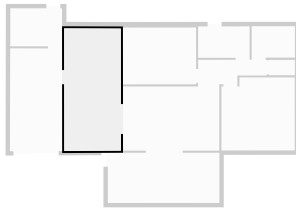

▼ **Hall**  
Ground Floor

WIDTH: 3.93 m • LENGTH: 1.40 m  
AREA: 4.66 m<sup>2</sup> • PERIMETER: 10.66 m

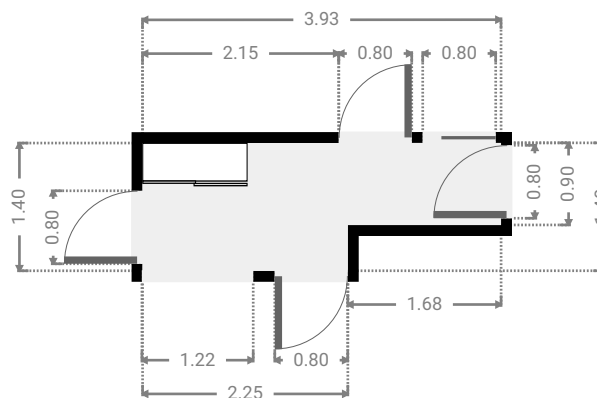
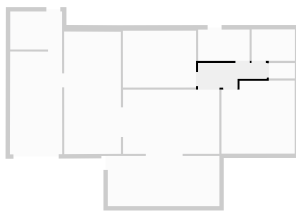

▼ **Bedroom**  
Ground Floor

WIDTH: 4.20 m • LENGTH: 3.26 m  
AREA: 13.69 m<sup>2</sup> • PERIMETER: 14.92 m

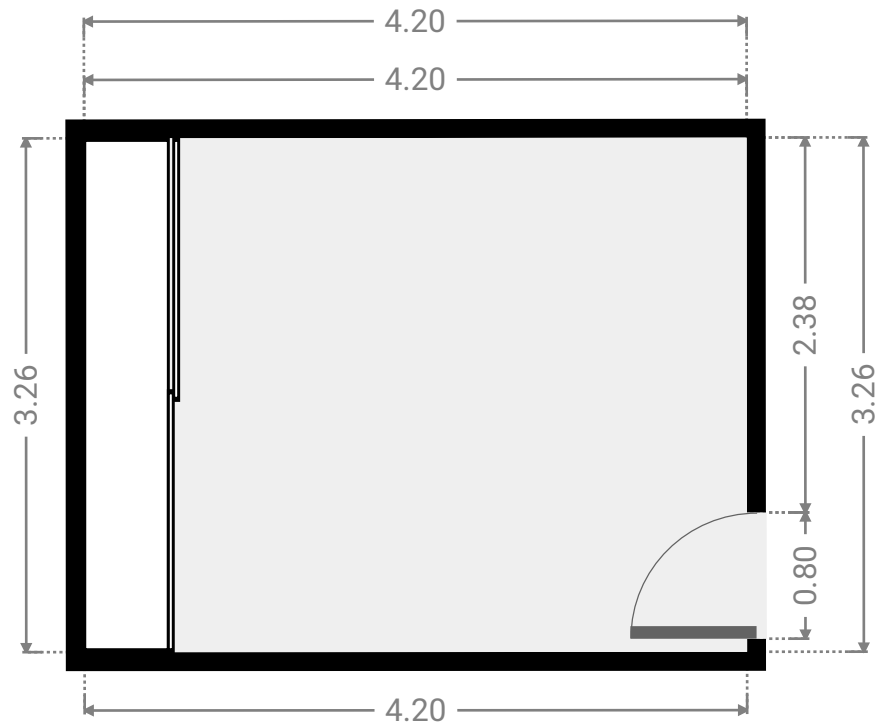
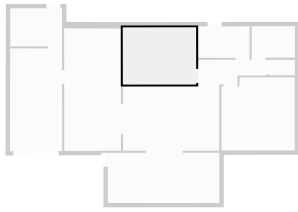

▼ **Laundry Room**  
Ground Floor

WIDTH: 2.95 m • LENGTH: 1.80 m  
AREA: 5.31 m<sup>2</sup> • PERIMETER: 9.50 m

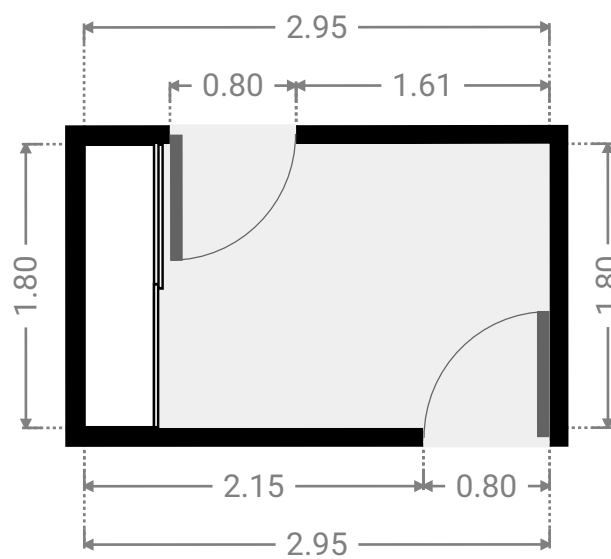
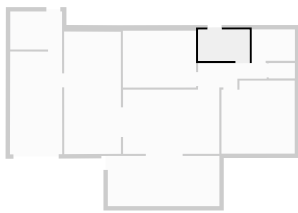

▼ **Bathroom**  
Ground Floor

WIDTH: 2.48 m • LENGTH: 1.80 m  
AREA: 4.46 m<sup>2</sup> • PERIMETER: 8.56 m

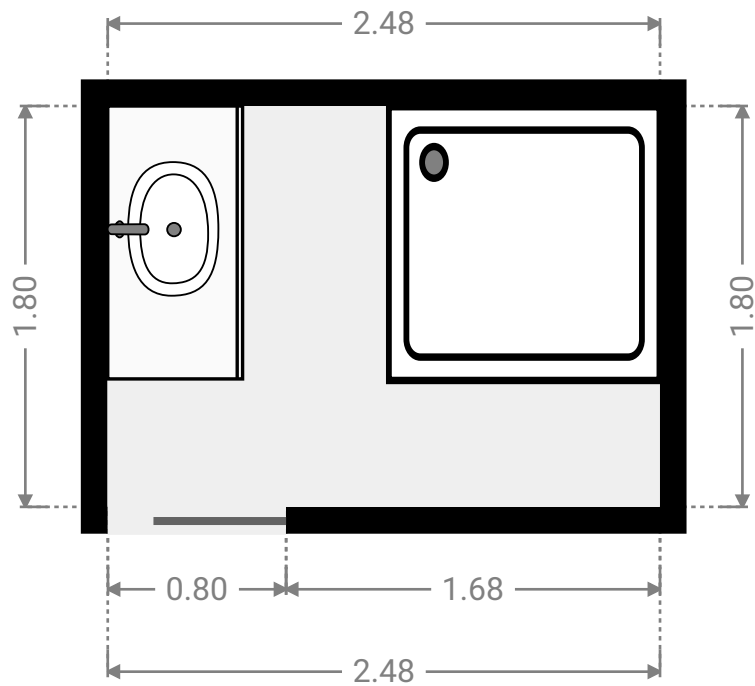
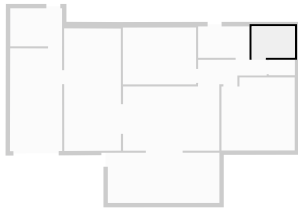

▼ **Toilet**  
Ground Floor

WIDTH: 1.50 m • LENGTH: 0.88 m  
AREA: 1.32 m<sup>2</sup> • PERIMETER: 4.76 m

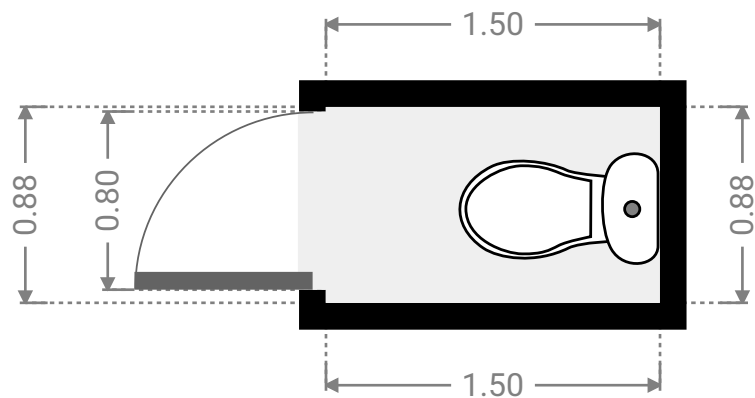
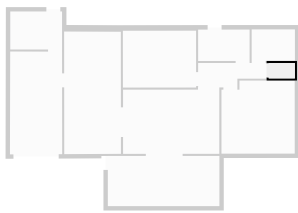

▼ **Master Bedroom**  
Ground Floor

WIDTH: 4.20 m • LENGTH: 4.19 m  
AREA: 17.05 m<sup>2</sup> • PERIMETER: 16.78 m

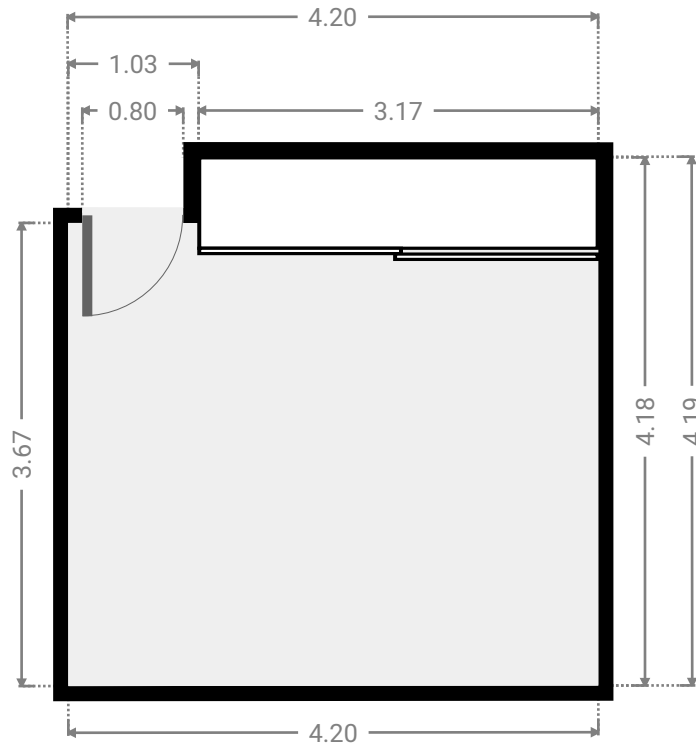
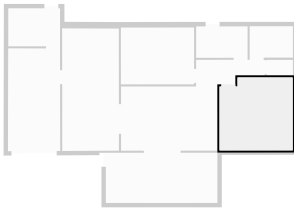

▼ **Closet**  
Ground Floor

WIDTH: 2.97 m • LENGTH: 2.18 m  
AREA: 6.47 m<sup>2</sup> • PERIMETER: 10.30 m

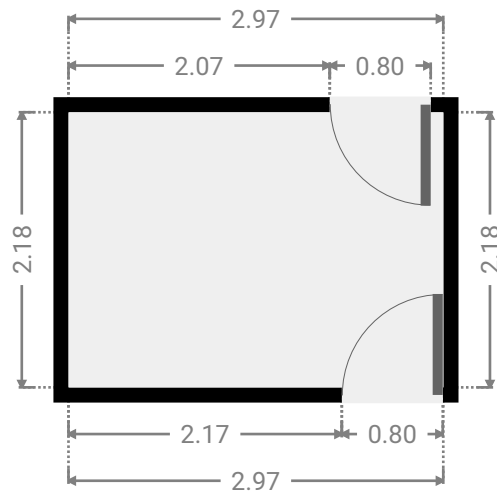
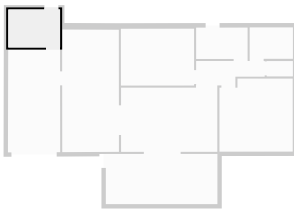

▼ **Garage**  
Ground Floor

WIDTH: 3.01 m • LENGTH: 5.90 m  
AREA: 17.58 m<sup>2</sup> • PERIMETER: 17.75 m

