

# 292 Denham Street Extended

**SUBMITTED BY**  
Ray White Rockhampton Casey  
stockers@cqoz.com

---

**CREATED ON**  
2022-05-05

---

**Floors**  
2

---

▼ Ground Floor

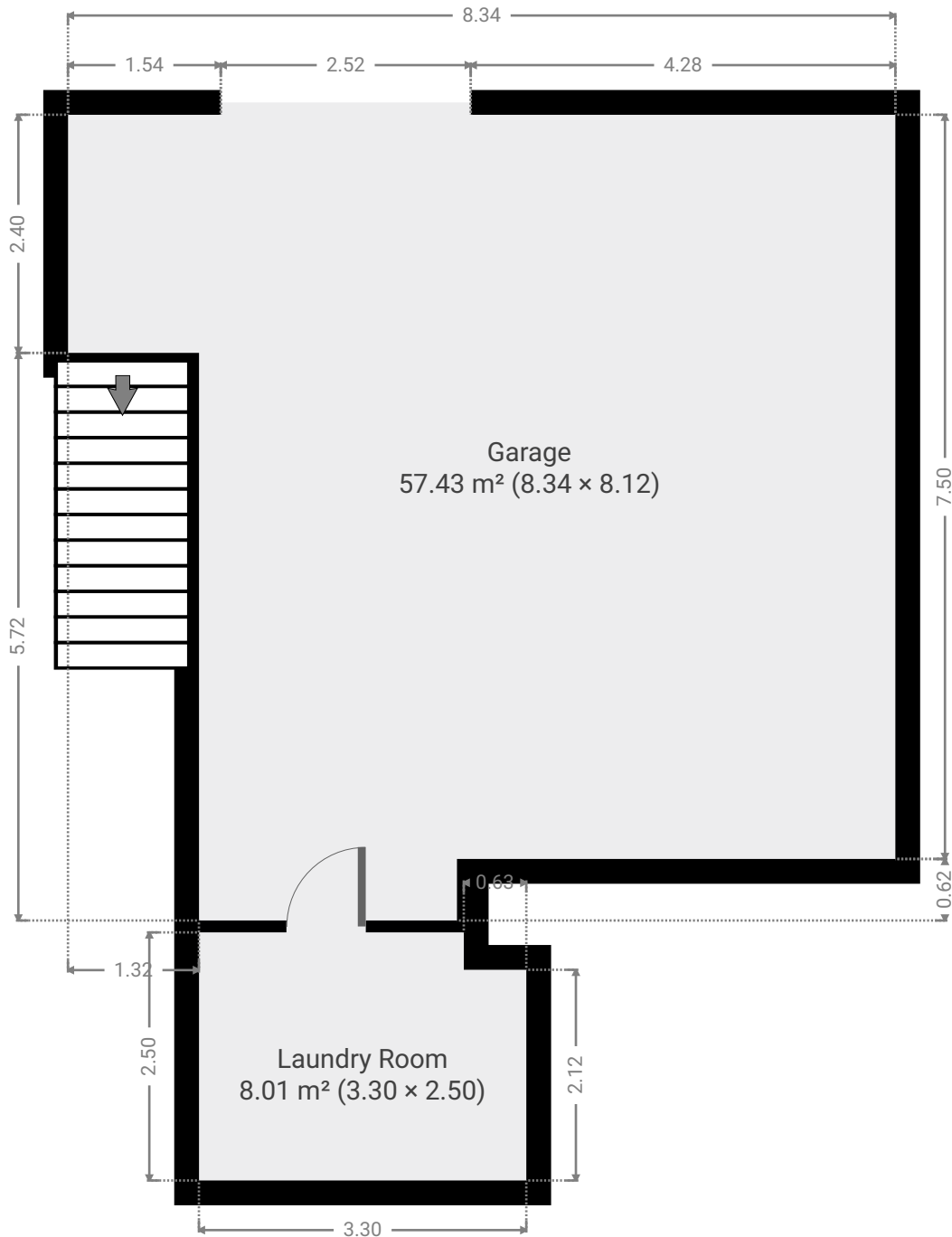

FLOORS: 2

▼ **Garage**  
Ground Floor

WIDTH: 8.12 m • LENGTH: 8.34 m  
AREA: 57.43 m<sup>2</sup> • PERIMETER: 32.92 m

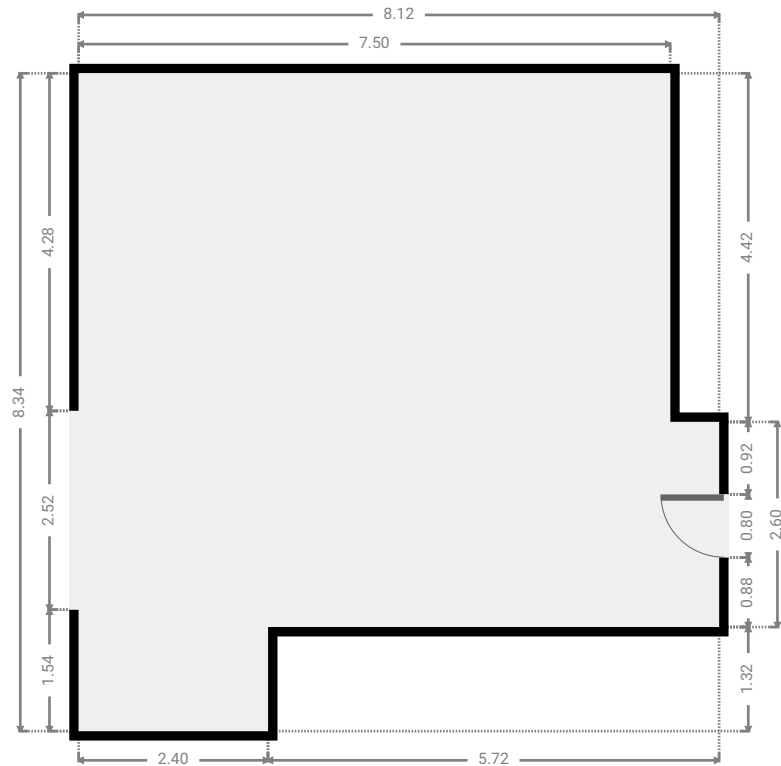
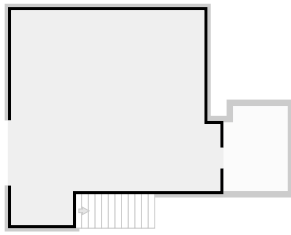

▼ **Laundry Room**  
Ground Floor

WIDTH: 2.50 m • LENGTH: 3.30 m  
AREA: 8.01 m<sup>2</sup> • PERIMETER: 11.60 m

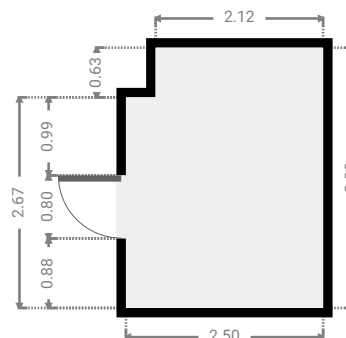
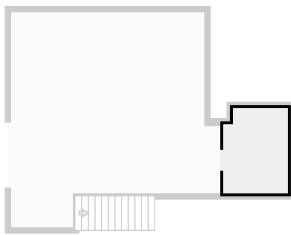

▼ 1st Floor

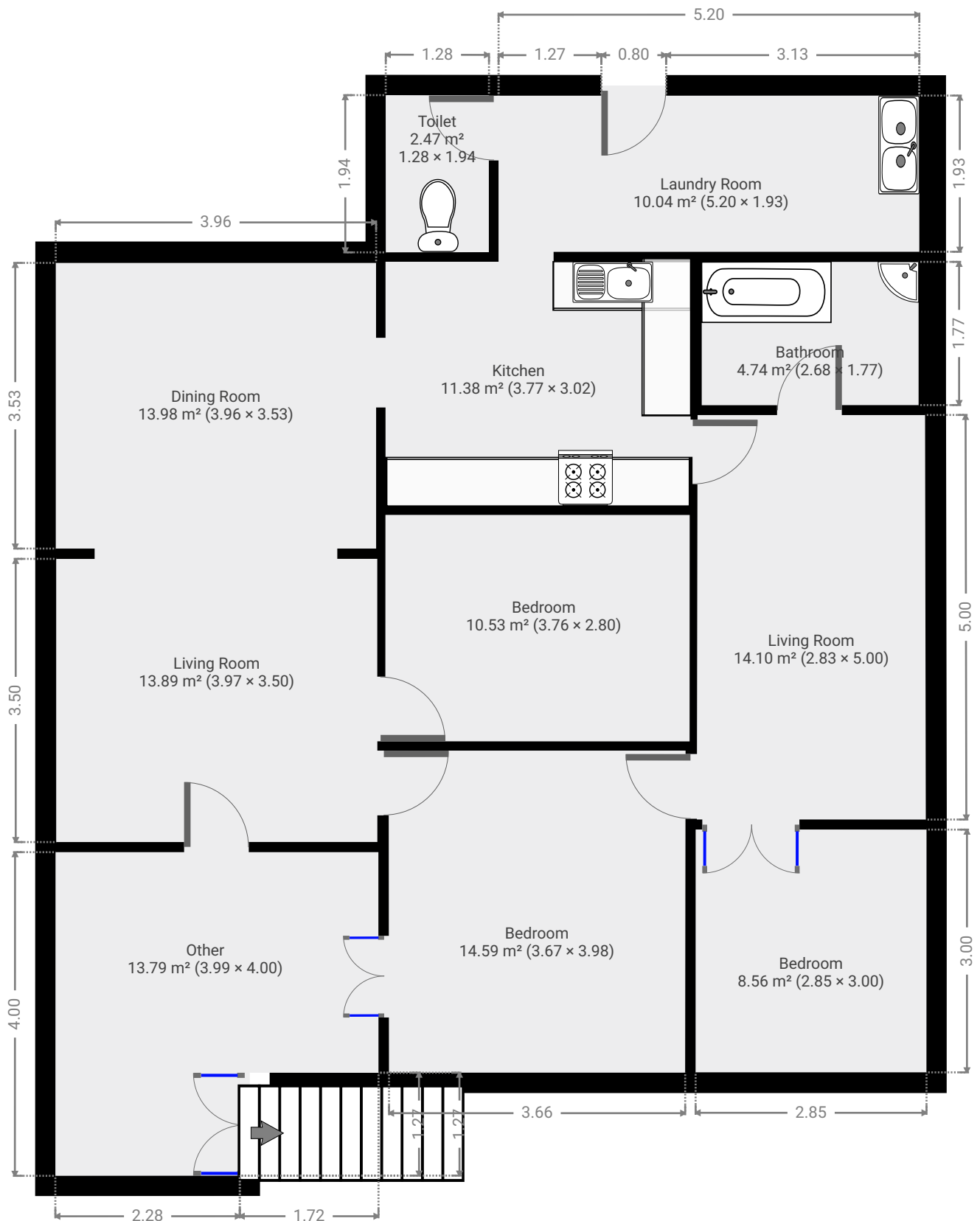

FLOORS: 2

▼ **Living Room**  
1st Floor

WIDTH: 3.97 m • LENGTH: 3.50 m  
AREA: 13.89 m<sup>2</sup> • PERIMETER: 14.94 m

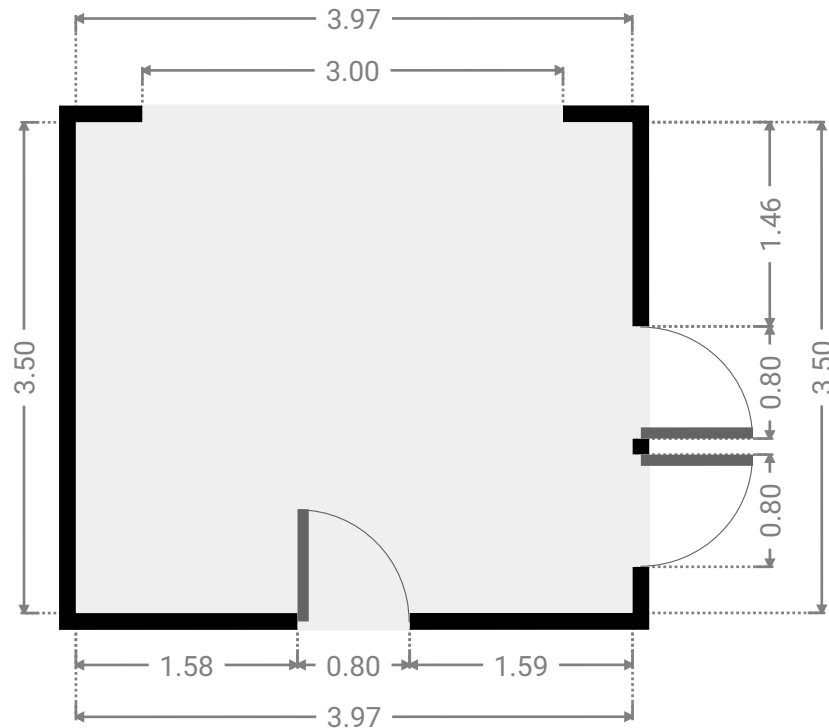
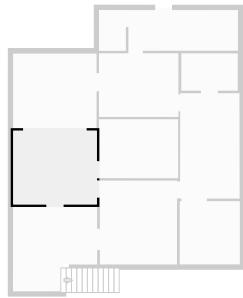

▼ **Bedroom**  
1st Floor

WIDTH: 3.67 m • LENGTH: 3.98 m  
AREA: 14.59 m<sup>2</sup> • PERIMETER: 15.29 m

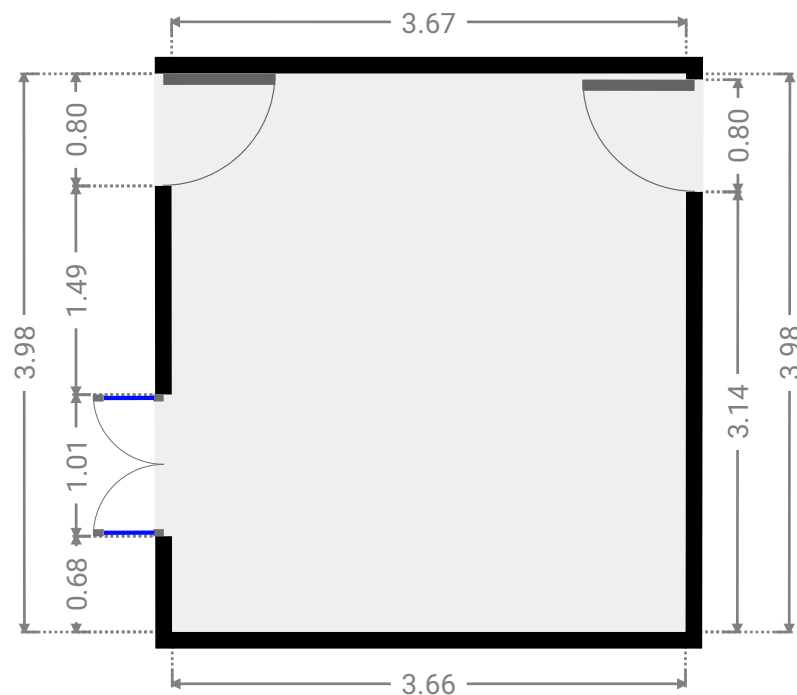
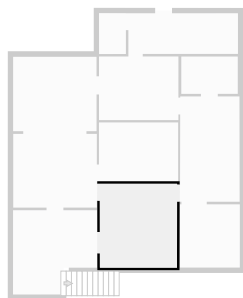

FLOORS: 2

▼ Bedroom  
1st Floor

WIDTH: 2.85 m • LENGTH: 3.00 m  
AREA: 8.56 m<sup>2</sup> • PERIMETER: 11.71 m

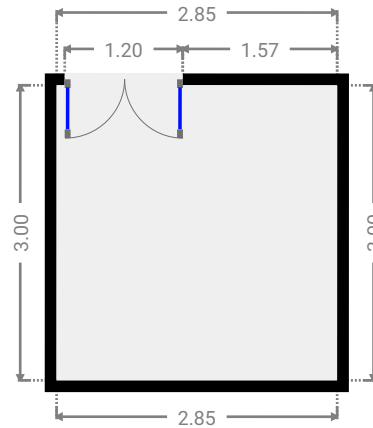
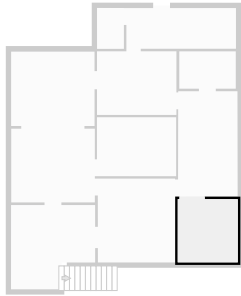

▼ Living Room  
1st Floor

WIDTH: 2.83 m • LENGTH: 5.00 m  
AREA: 14.10 m<sup>2</sup> • PERIMETER: 15.64 m

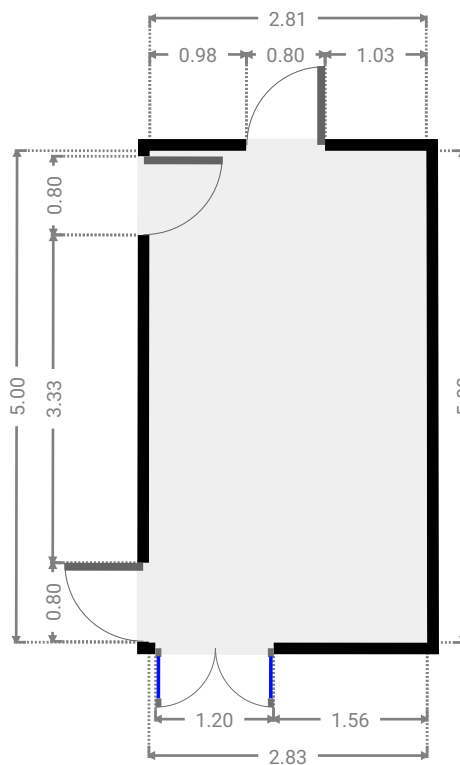
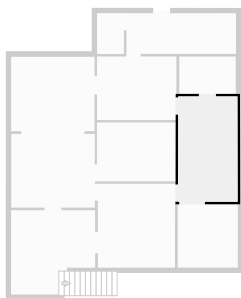

FLOORS: 2

▼ **Bedroom**  
1st Floor

WIDTH: 3.76 m • LENGTH: 2.80 m  
AREA: 10.53 m<sup>2</sup> • PERIMETER: 13.12 m

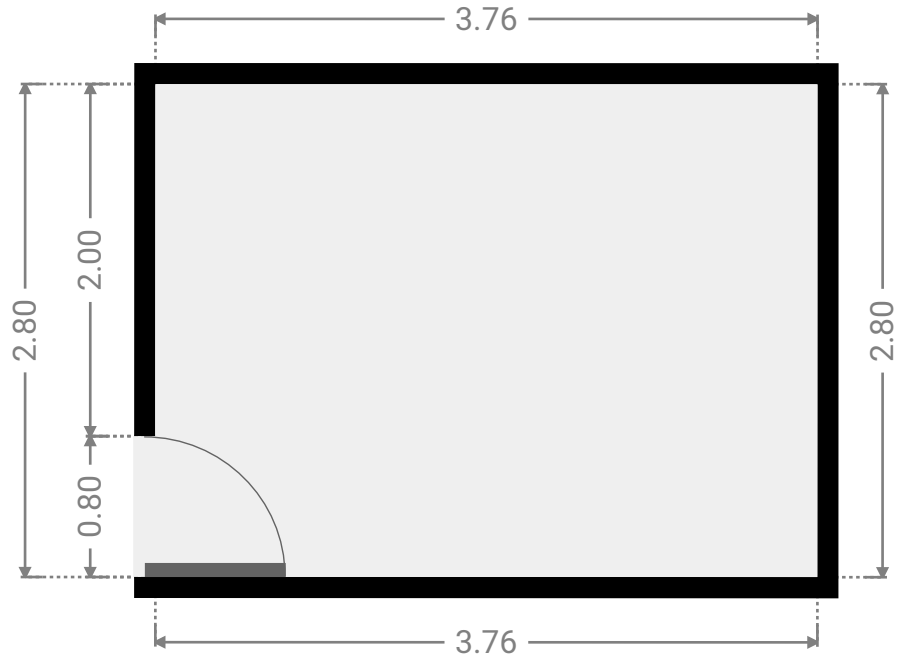
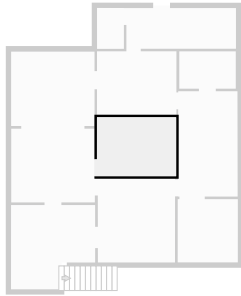

▼ **Bathroom**  
1st Floor

WIDTH: 2.68 m • LENGTH: 1.77 m  
AREA: 4.74 m<sup>2</sup> • PERIMETER: 8.90 m

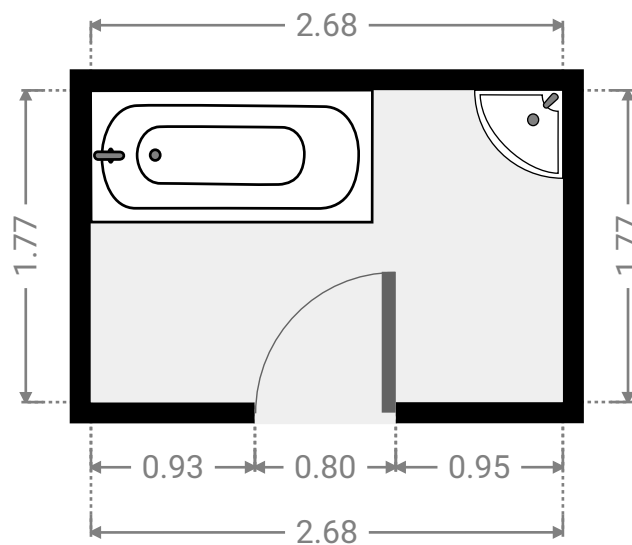
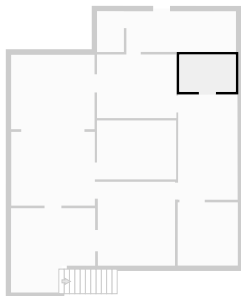

▼ **Kitchen**  
1st Floor

WIDTH: 3.77 m • LENGTH: 3.02 m  
AREA: 11.38 m<sup>2</sup> • PERIMETER: 13.58 m

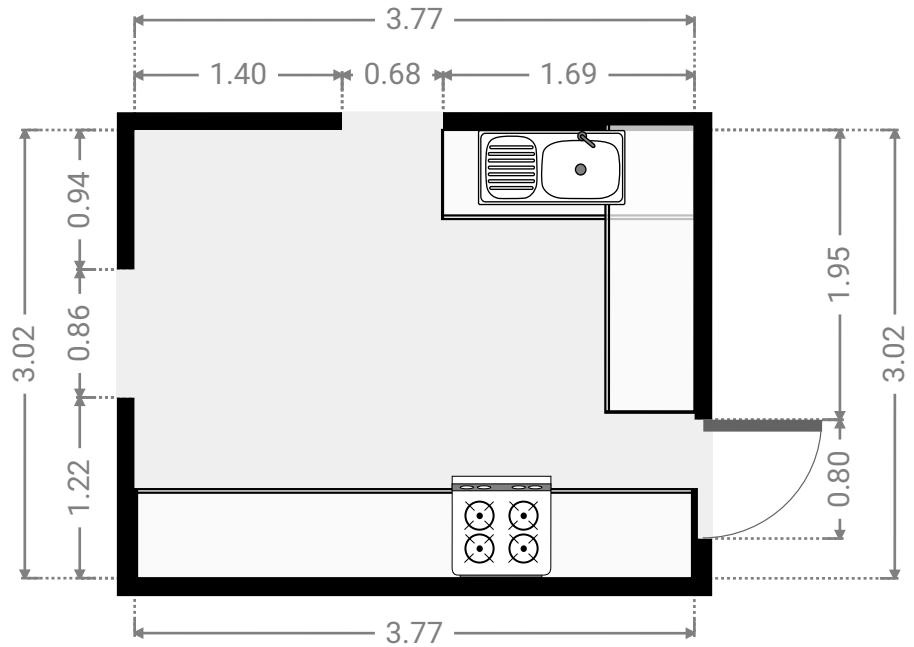
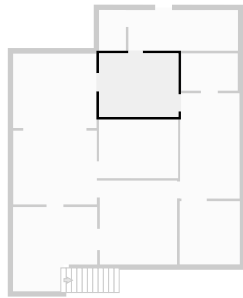

▼ **Dining Room**  
1st Floor

WIDTH: 3.96 m • LENGTH: 3.53 m  
AREA: 13.98 m<sup>2</sup> • PERIMETER: 14.98 m

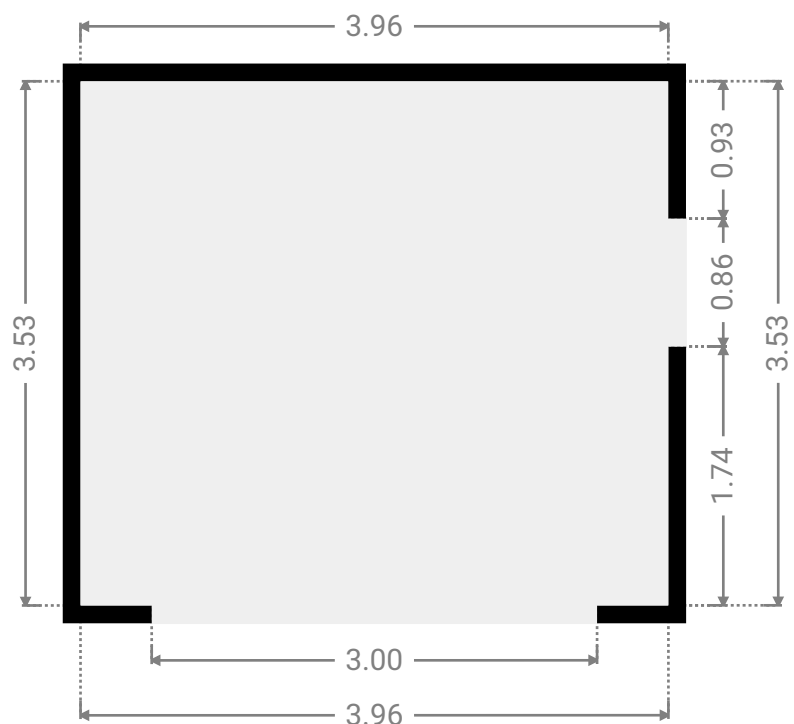
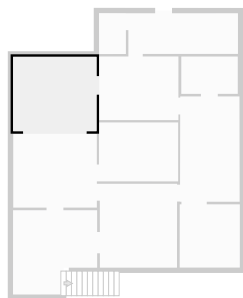



FLOORS: 2

▼ **Laundry Room**  
1st Floor

WIDTH: 5.20 m • LENGTH: 1.93 m  
AREA: 10.04 m<sup>2</sup> • PERIMETER: 14.26 m

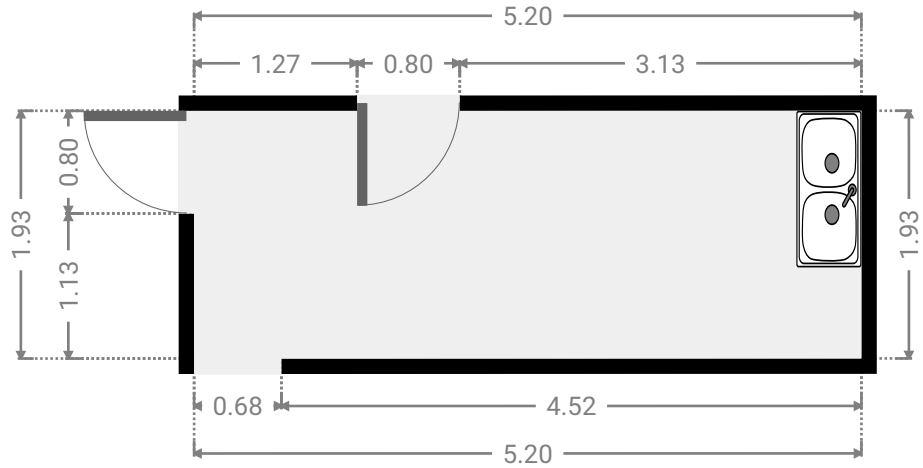
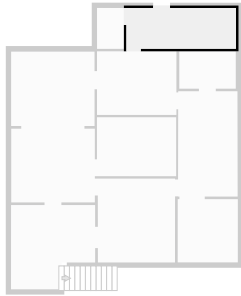

▼ **Toilet**  
1st Floor

WIDTH: 1.28 m • LENGTH: 1.94 m  
AREA: 2.47 m<sup>2</sup> • PERIMETER: 6.43 m

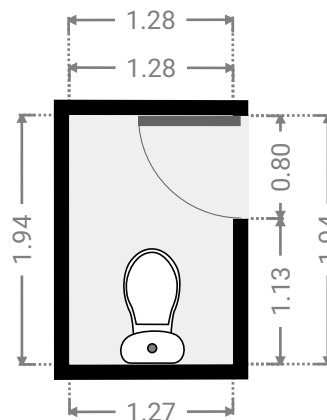
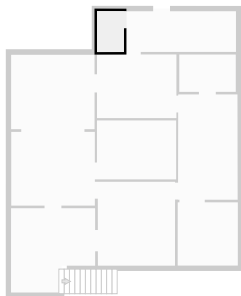

FLOORS: 2

## ▼ Other 1st Floor

WIDTH: 3.99 m • LENGTH: 4.00 m  
AREA: 13.79 m<sup>2</sup> • PERIMETER: 15.99 m

