

292 BLANCHFIELD STREET

SUBMITTED BY
Ray White Rockhampton Casey
stockers@cqoz.com

CREATED ON
2022-09-21

Floors
2

▼ Ground Floor

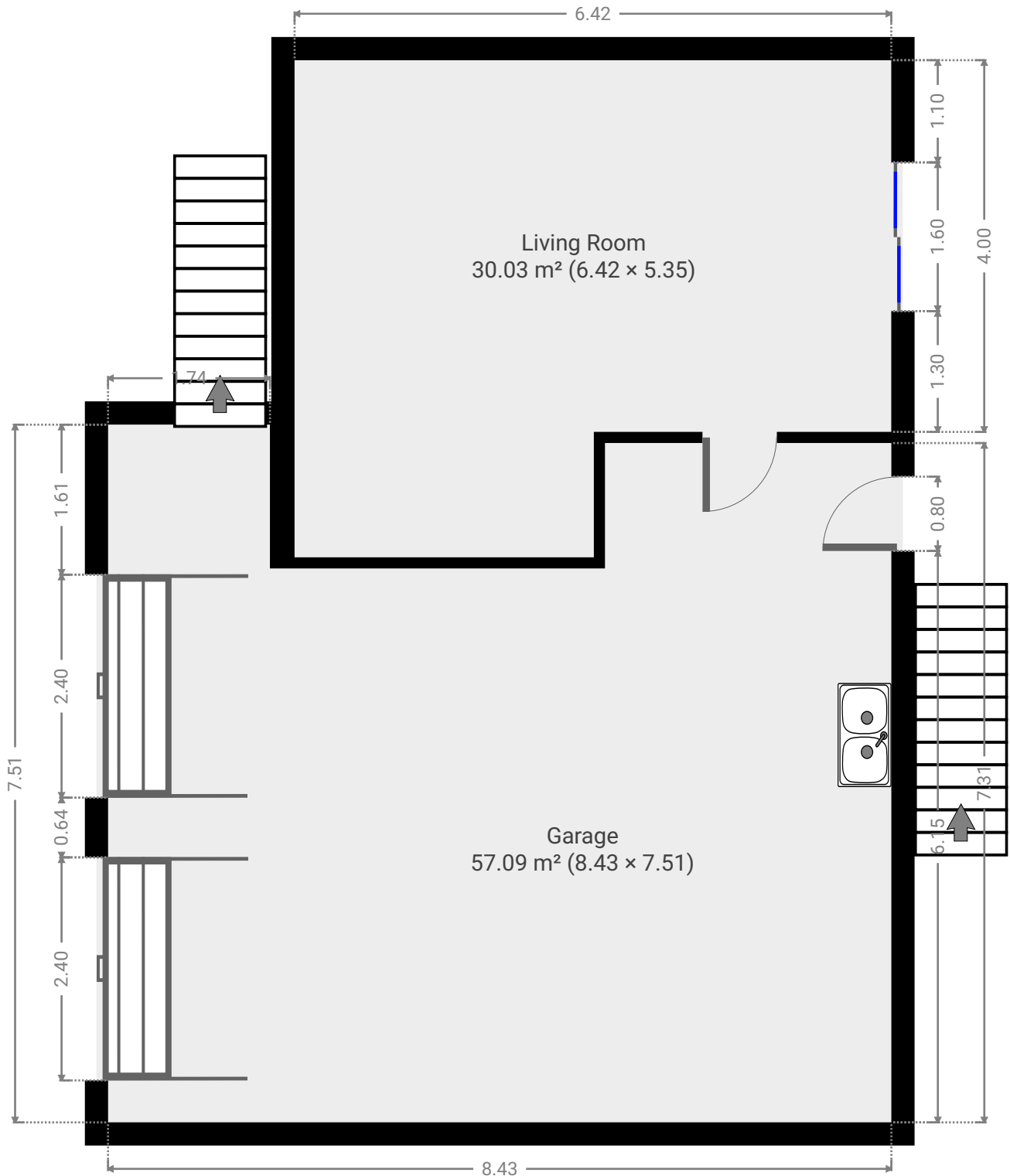

▼ **Garage**
Ground Floor

WIDTH: 7.51 m • LENGTH: 8.43 m
AREA: 57.09 m² • PERIMETER: 34.57 m

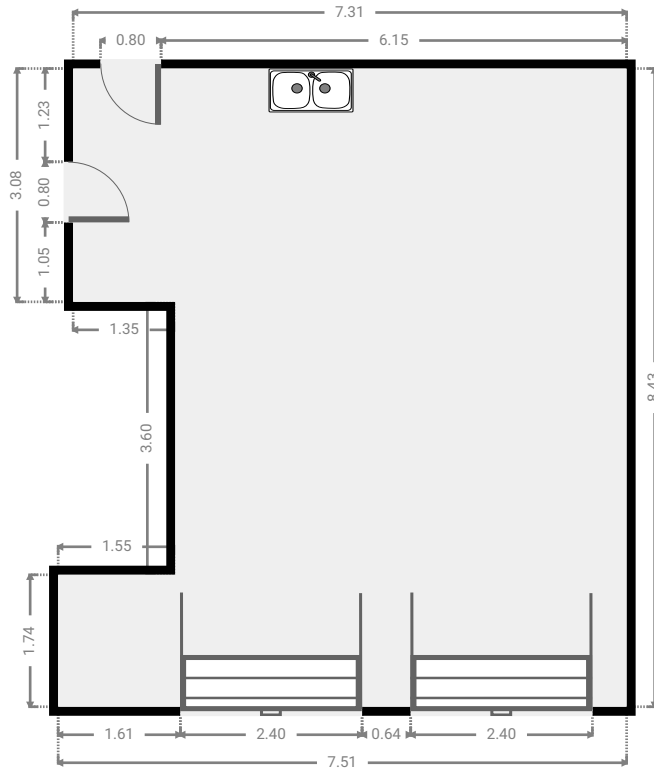
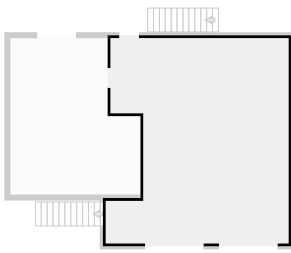

▼ **Living Room**
Ground Floor

WIDTH: 5.35 m • LENGTH: 6.42 m
AREA: 30.03 m² • PERIMETER: 23.54 m

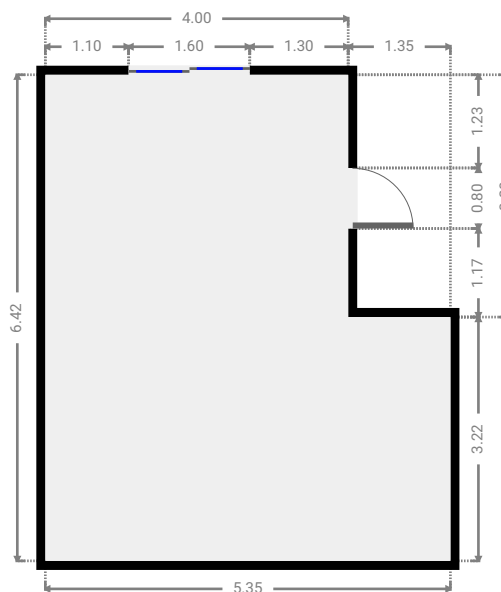
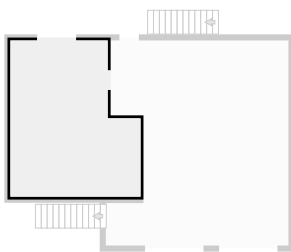

▼ 1st Floor

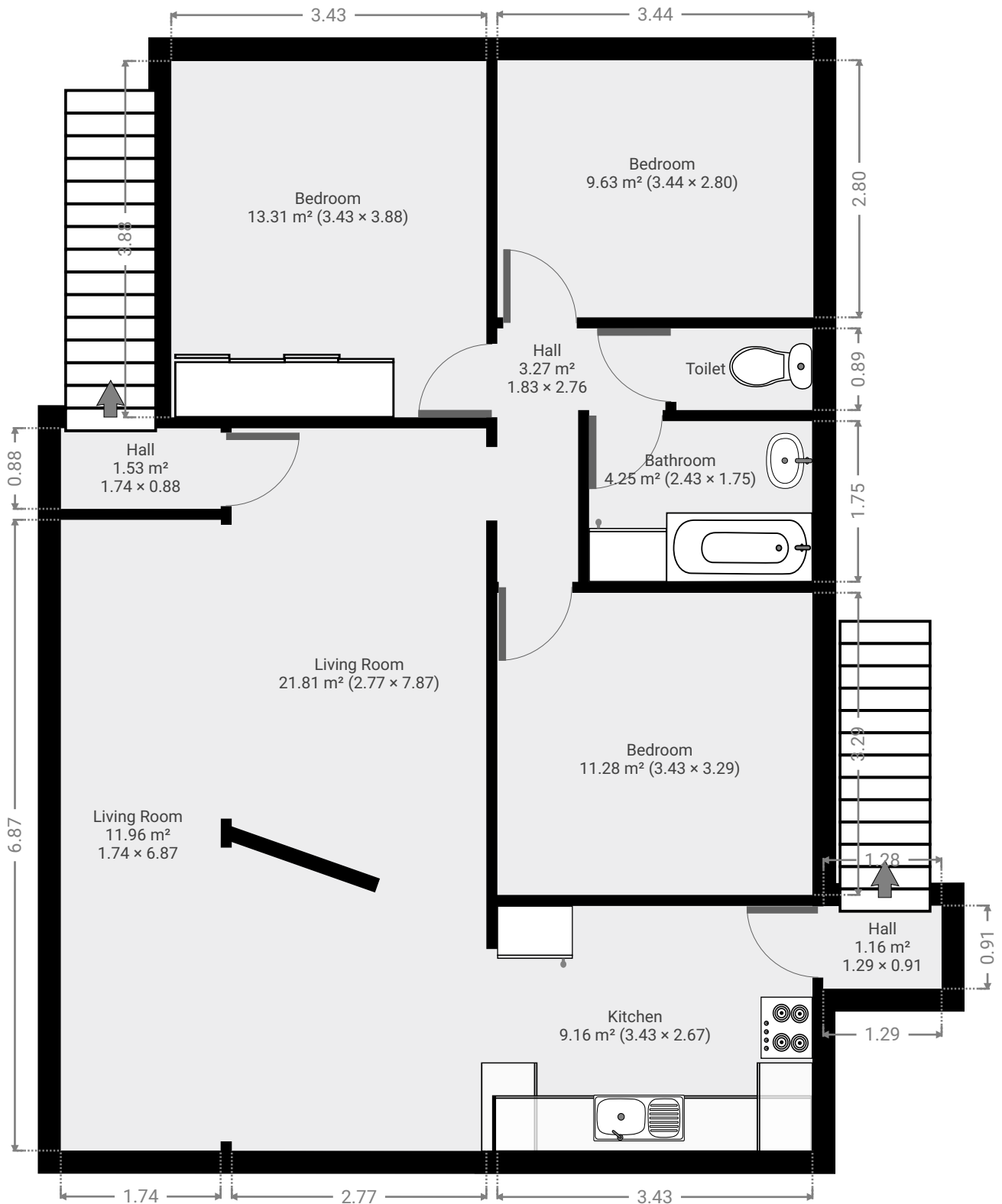

▼ **Bathroom**
1st Floor

WIDTH: 1.75 m • LENGTH: 2.43 m
AREA: 4.25 m² • PERIMETER: 8.36 m

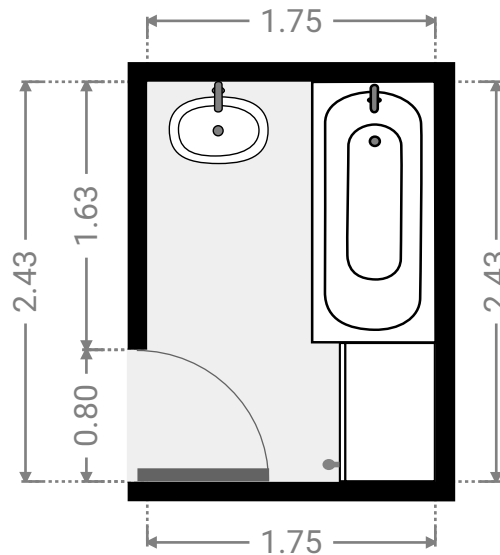
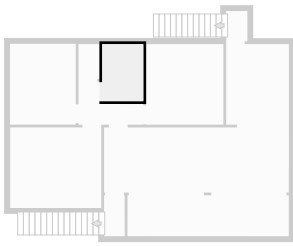

▼ **Bedroom**
1st Floor

WIDTH: 3.29 m • LENGTH: 3.43 m
AREA: 11.28 m² • PERIMETER: 13.44 m

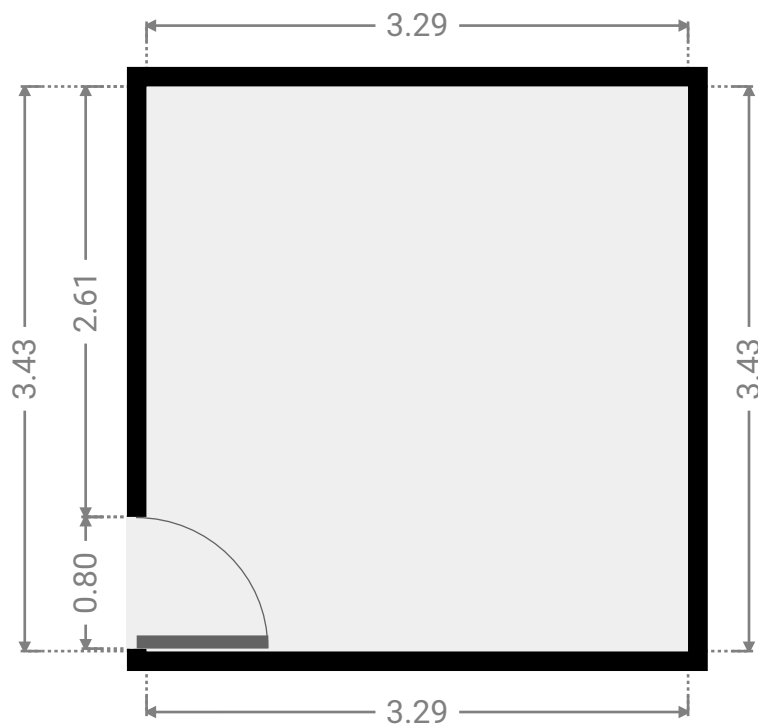
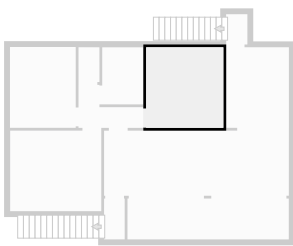

▼ **Bedroom**
1st Floor

WIDTH: 2.80 m • LENGTH: 3.44 m
AREA: 9.63 m² • PERIMETER: 12.48 m

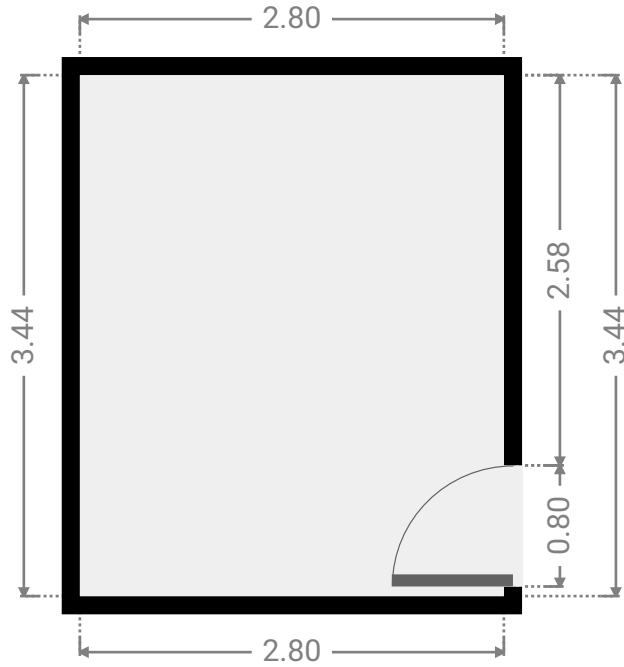
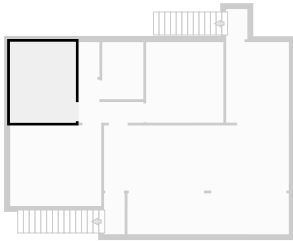

▼ **Bedroom**
1st Floor

WIDTH: 3.88 m • LENGTH: 3.43 m
AREA: 13.31 m² • PERIMETER: 14.62 m

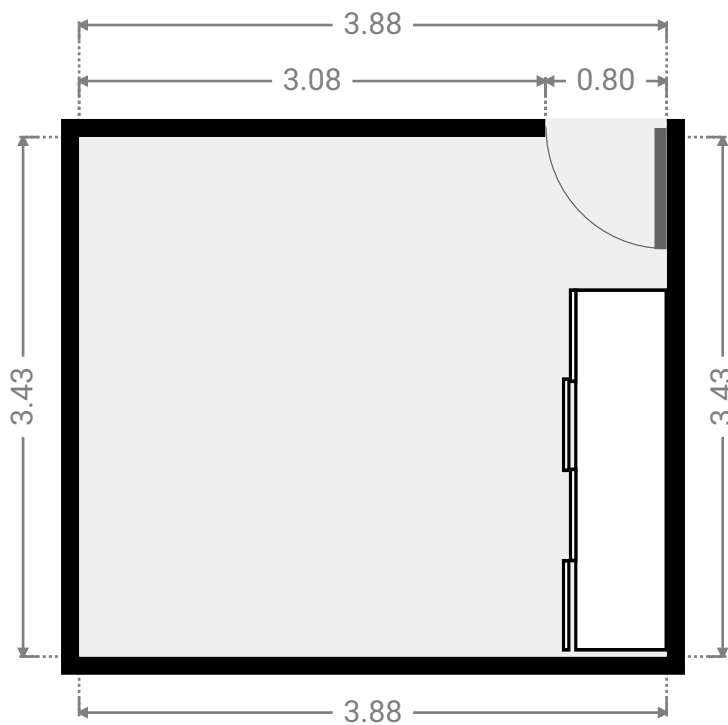
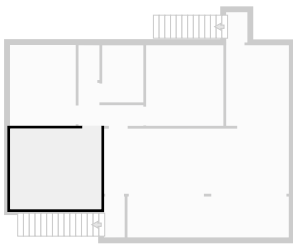

▼ **Hall**
1st Floor

WIDTH: 2.76 m • LENGTH: 1.83 m
AREA: 3.27 m² • PERIMETER: 9.18 m

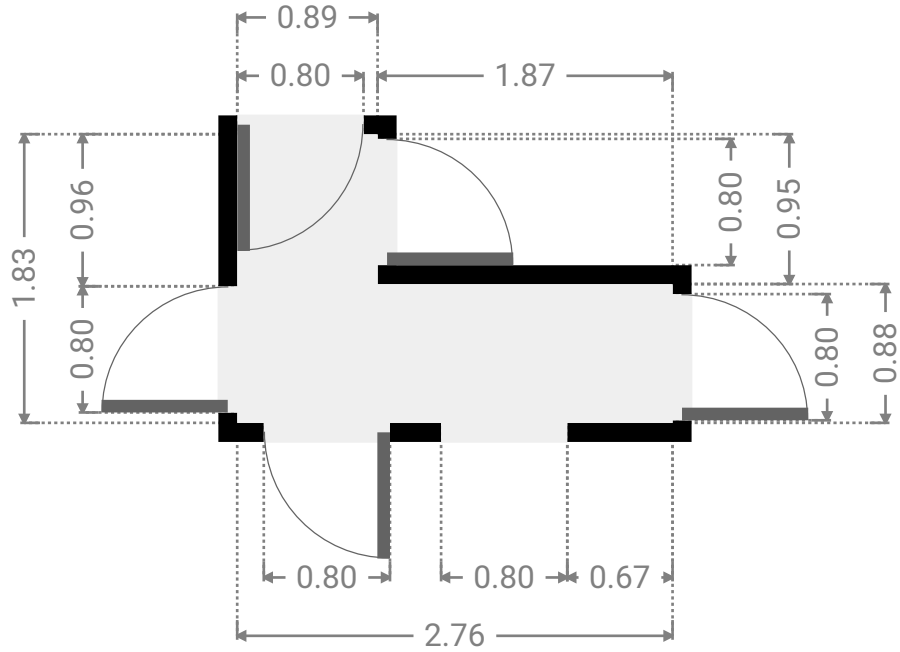

▼ **Hall**
1st Floor

WIDTH: 0.88 m • LENGTH: 1.74 m
AREA: 1.53 m² • PERIMETER: 5.23 m

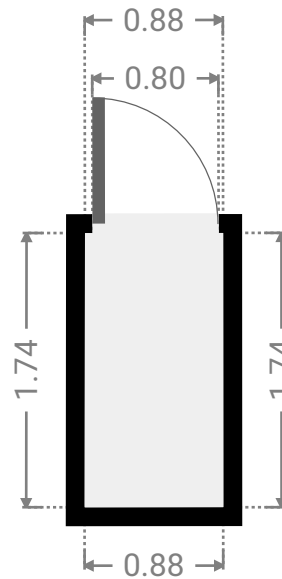
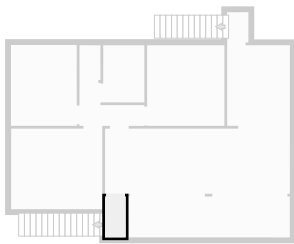

▼ **Hall**
1st Floor

WIDTH: 0.91 m • LENGTH: 1.29 m
AREA: 1.16 m² • PERIMETER: 4.38 m

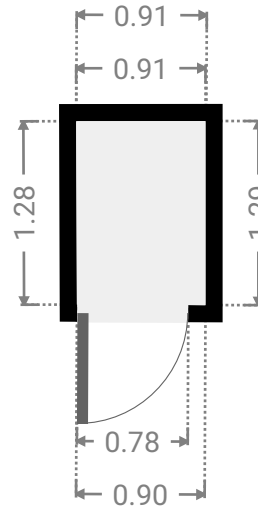
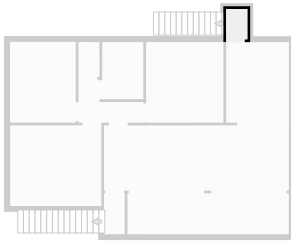

▼ **Kitchen**
1st Floor

WIDTH: 2.67 m • LENGTH: 3.43 m
AREA: 9.16 m² • PERIMETER: 12.20 m

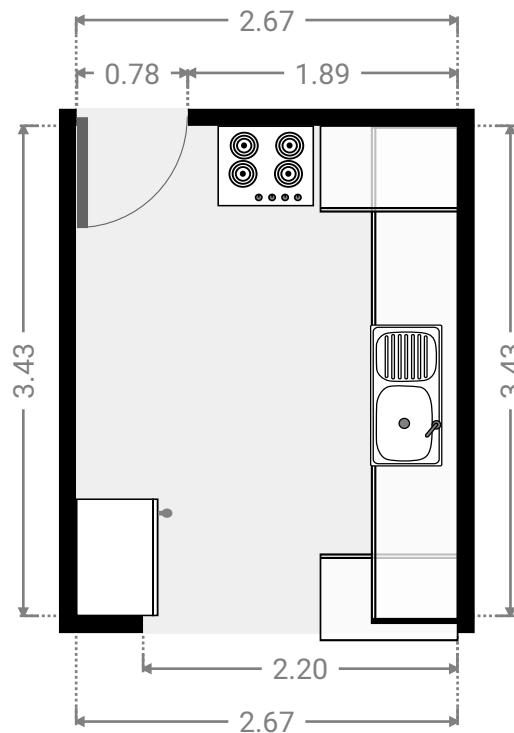
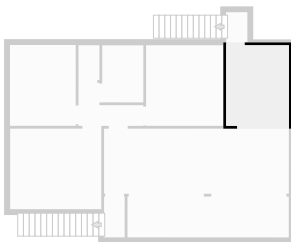

▼ Living Room
1st Floor

WIDTH: 6.87 m • LENGTH: 1.74 m
AREA: 11.96 m² • PERIMETER: 17.22 m

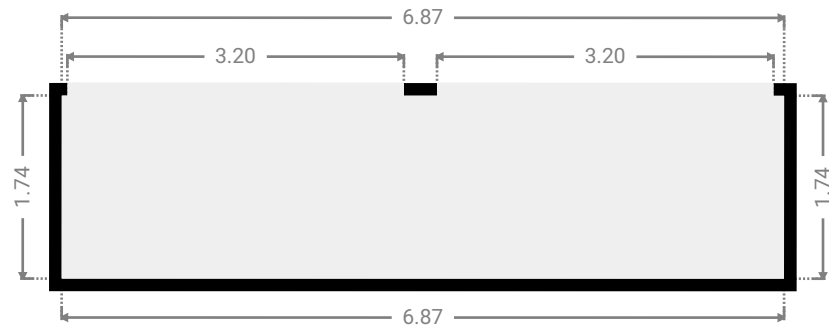
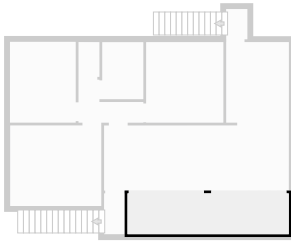

▼ Living Room
1st Floor

WIDTH: 7.87 m • LENGTH: 2.77 m
AREA: 21.81 m² • PERIMETER: 21.28 m

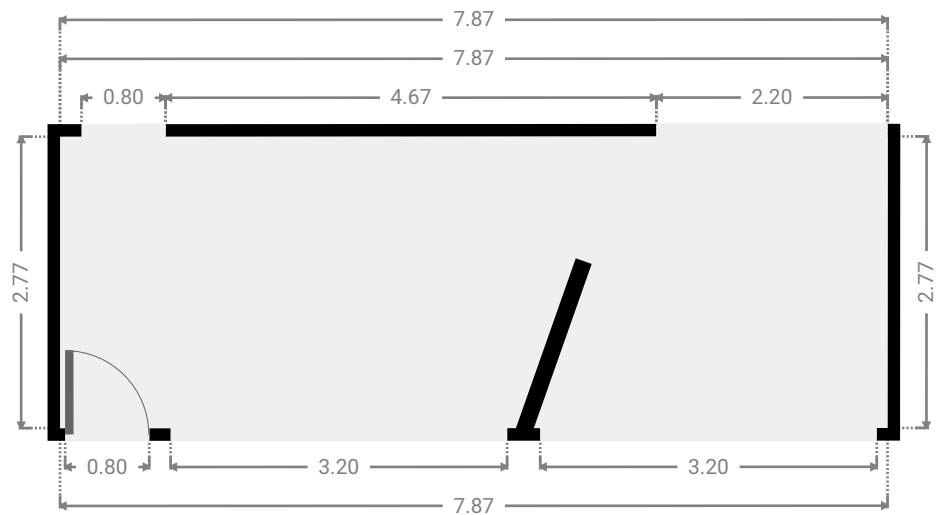
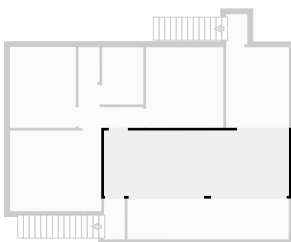

▼ Toilet
1st Floor

WIDTH: 0.89 m • LENGTH: 1.48 m
AREA: 1.32 m² • PERIMETER: 4.74 m

