

29 Goodson Street

SUBMITTED BY

Ray White Rockhampton Casey
stockers@cqoz.com

CREATED ON

2022-11-02

Floors

2

▼ Ground Floor

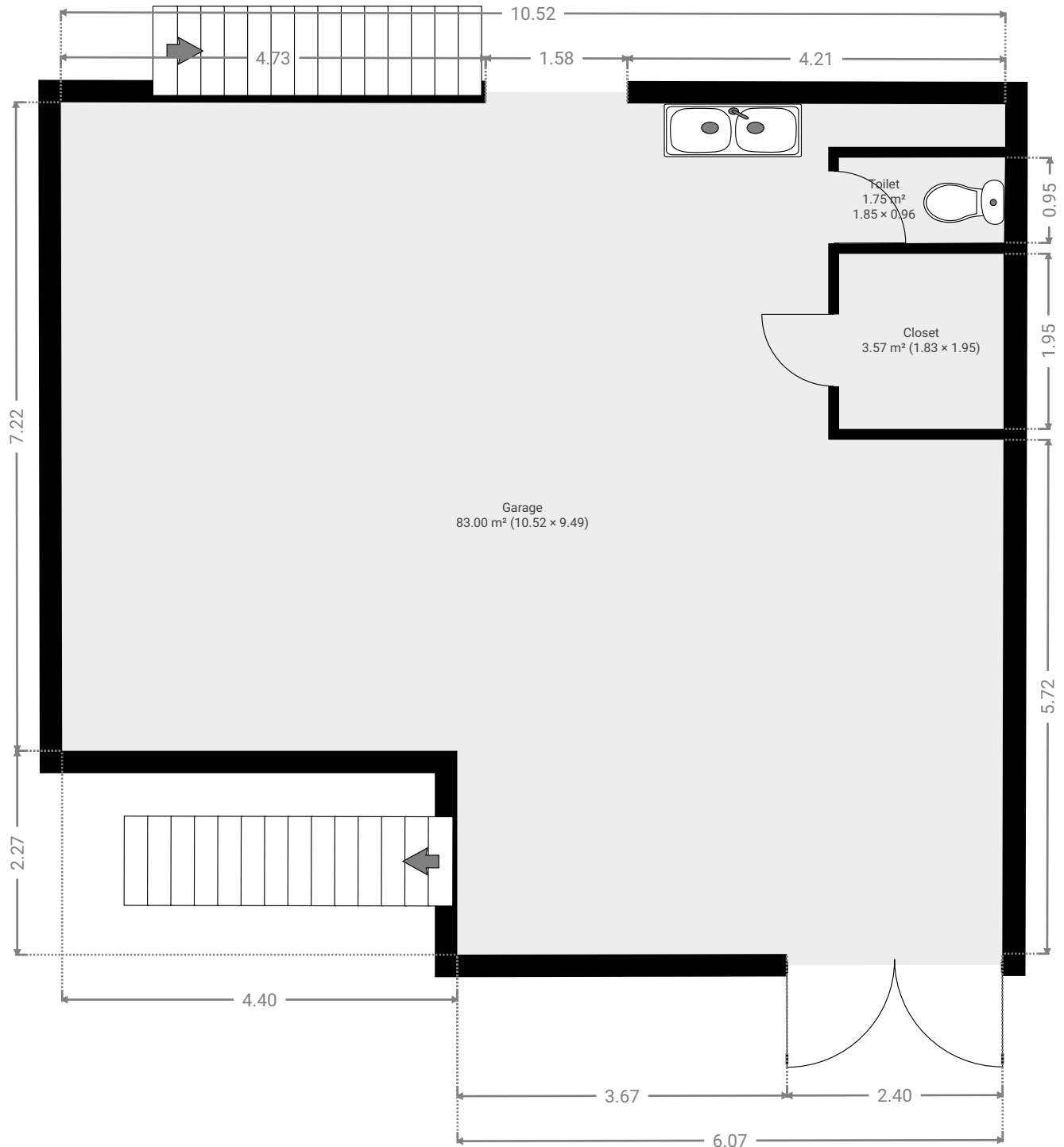

▼ **Garage**
Ground Floor

WIDTH: 10.52 m • LENGTH: 9.49 m
AREA: 83.00 m² • PERIMETER: 43.85 m

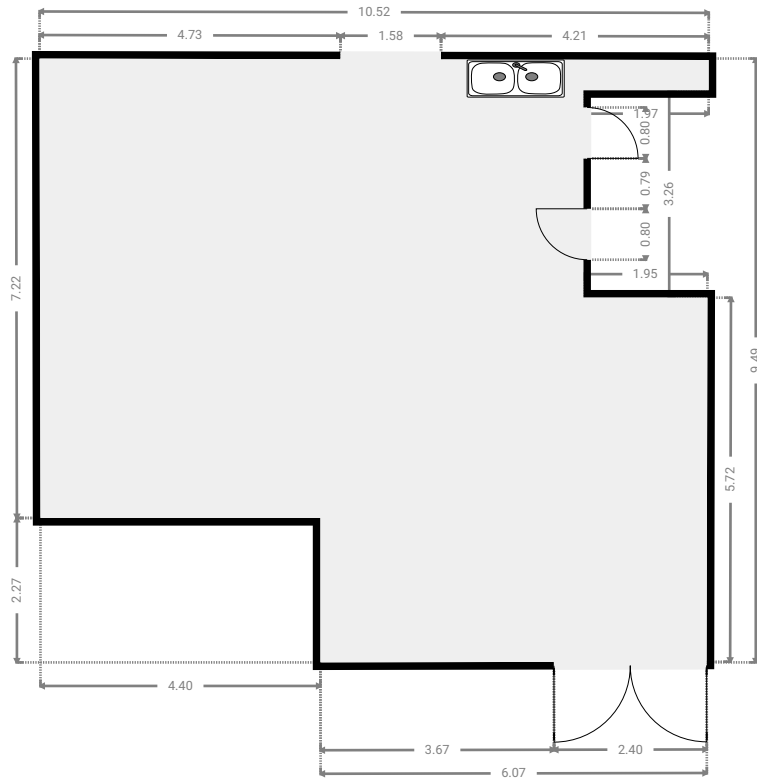
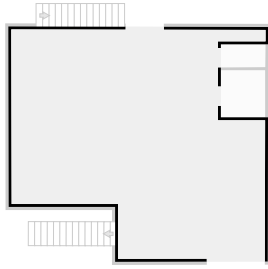

▼ **Closet**
Ground Floor

WIDTH: 1.83 m • LENGTH: 1.95 m
AREA: 3.57 m² • PERIMETER: 7.56 m

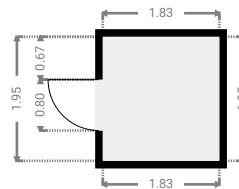
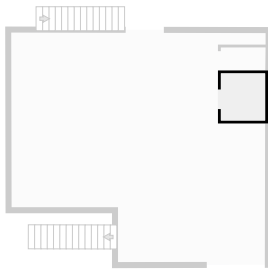

▼ Toilet
Ground Floor

WIDTH: 1.85 m • LENGTH: 0.96 m
AREA: 1.75 m² • PERIMETER: 5.59 m

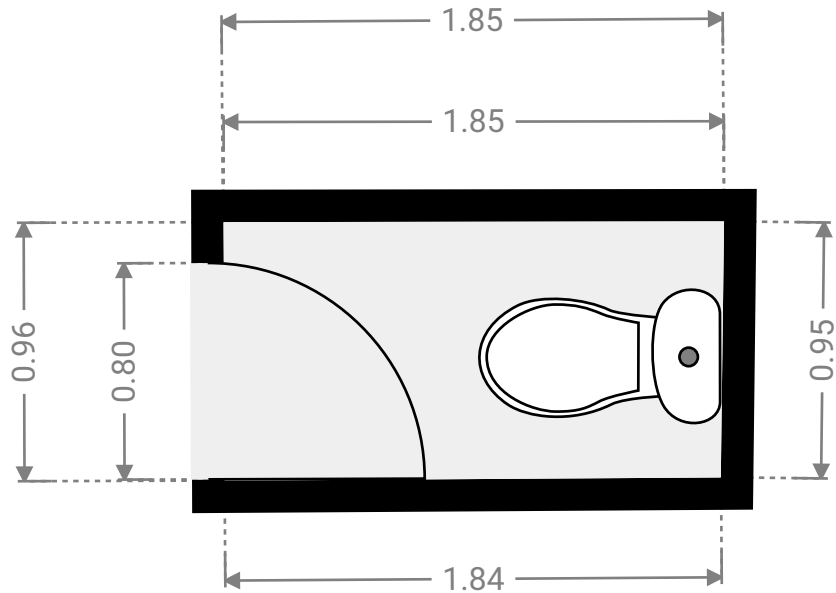
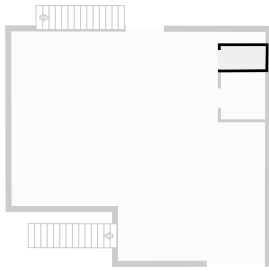

▼ 1st Floor

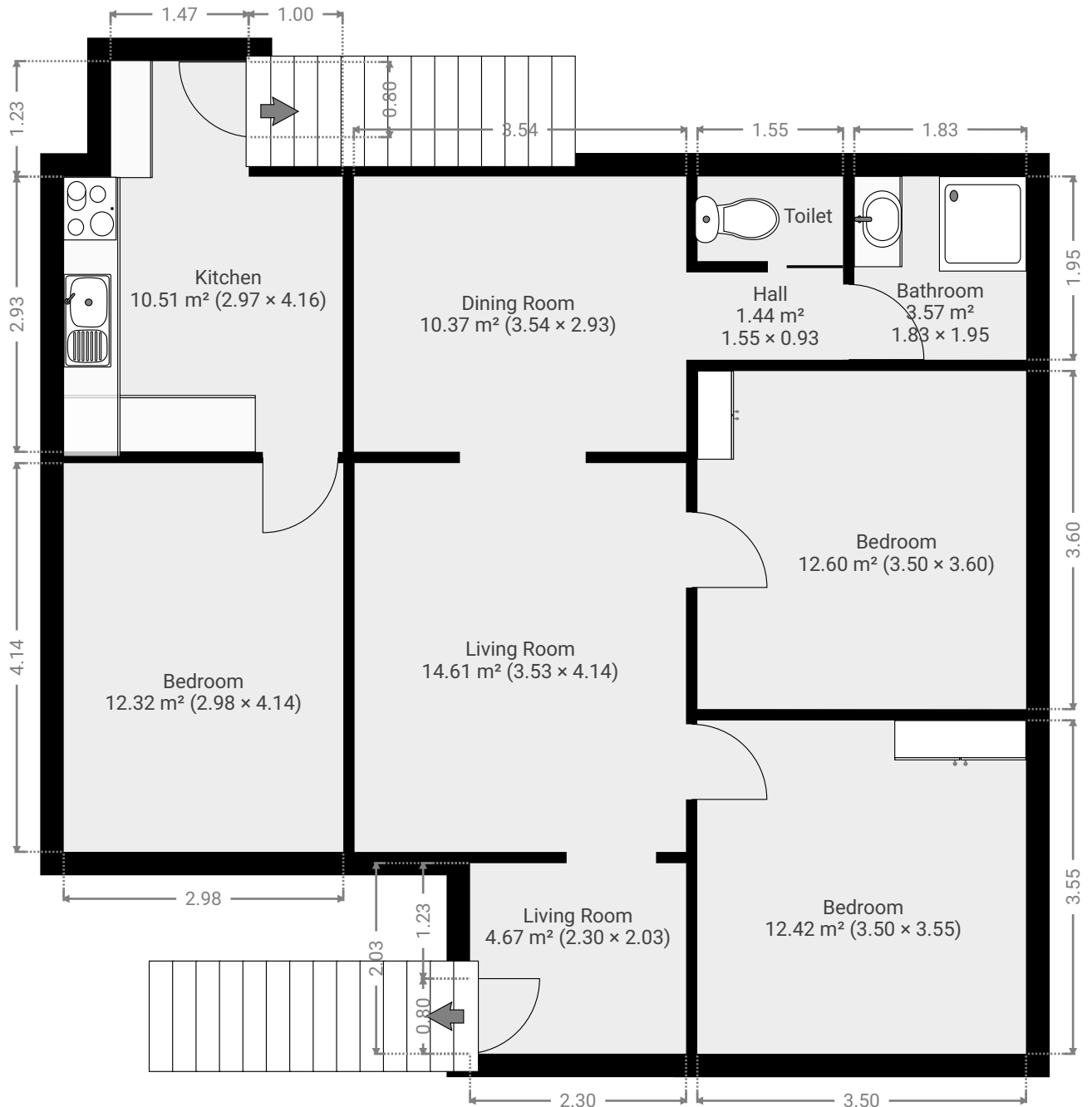

▼ **Bathroom**
1st Floor

WIDTH: 1.83 m • LENGTH: 1.95 m
AREA: 3.57 m² • PERIMETER: 7.56 m

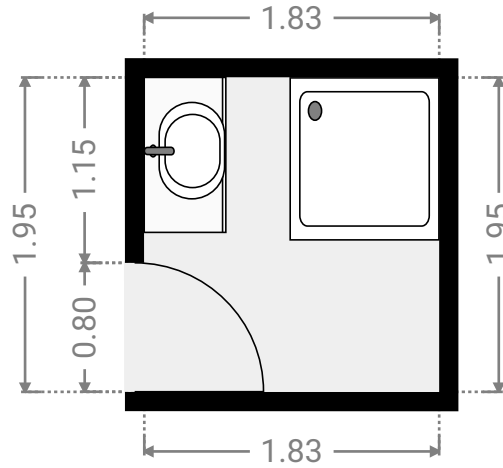
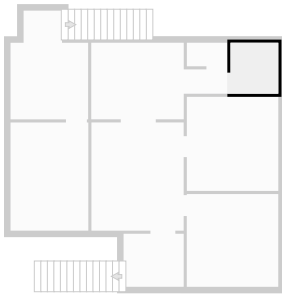

▼ **Bedroom**
1st Floor

WIDTH: 3.50 m • LENGTH: 3.55 m
AREA: 12.42 m² • PERIMETER: 14.10 m

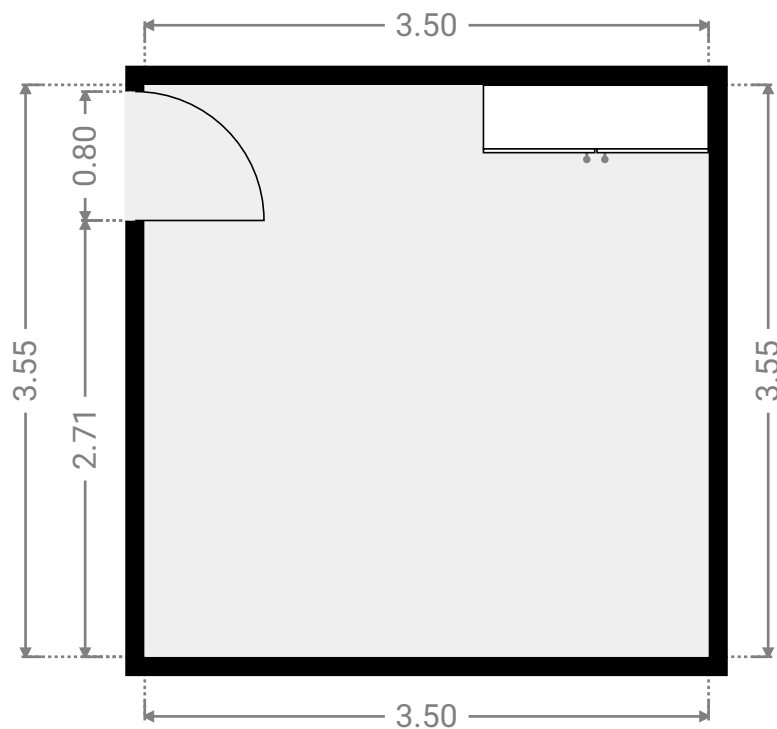
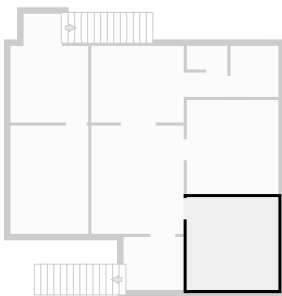

▼ **Bedroom**
1st Floor

WIDTH: 3.50 m • LENGTH: 3.60 m
AREA: 12.60 m² • PERIMETER: 14.20 m

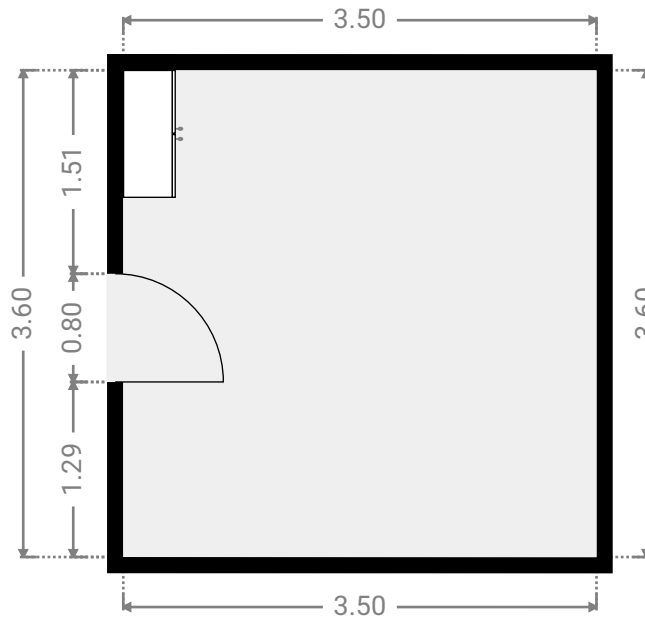
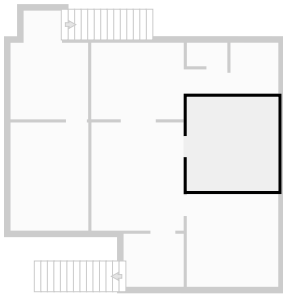

▼ **Bedroom**
1st Floor

WIDTH: 2.98 m • LENGTH: 4.14 m
AREA: 12.32 m² • PERIMETER: 14.23 m

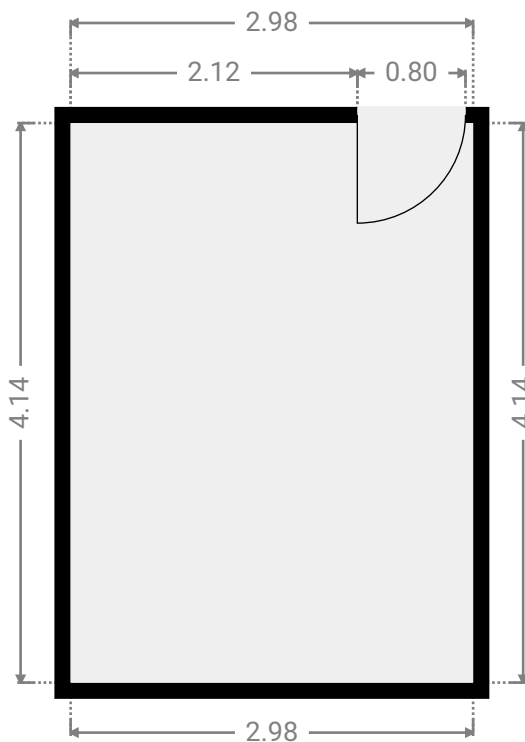
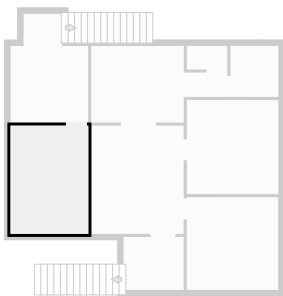

▼ **Dining Room**
1st Floor

WIDTH: 3.54 m • LENGTH: 2.93 m
AREA: 10.37 m² • PERIMETER: 12.94 m

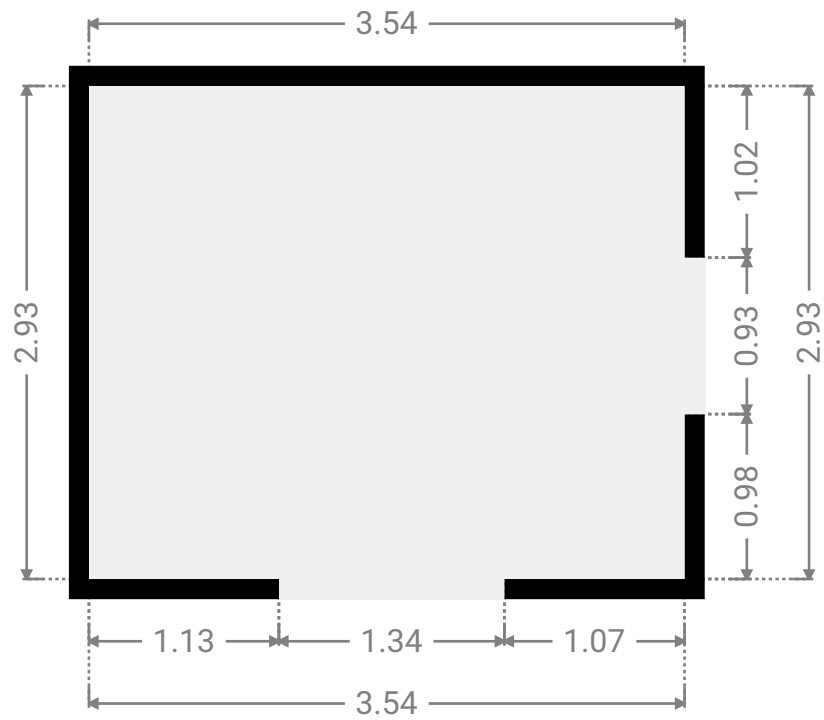

▼ **Hall**
1st Floor

WIDTH: 1.55 m • LENGTH: 0.93 m
AREA: 1.44 m² • PERIMETER: 4.96 m

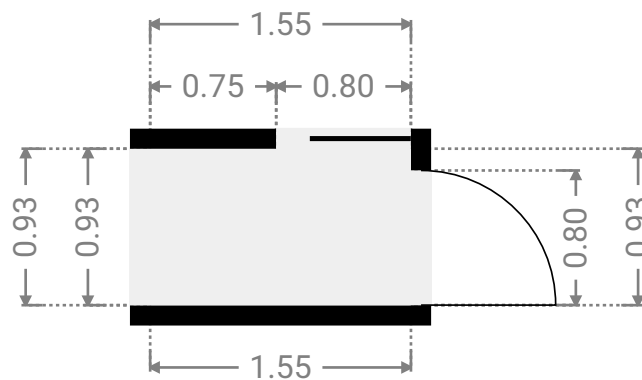

▼ Kitchen
1st Floor

WIDTH: 2.97 m • LENGTH: 4.16 m
AREA: 10.51 m² • PERIMETER: 14.26 m

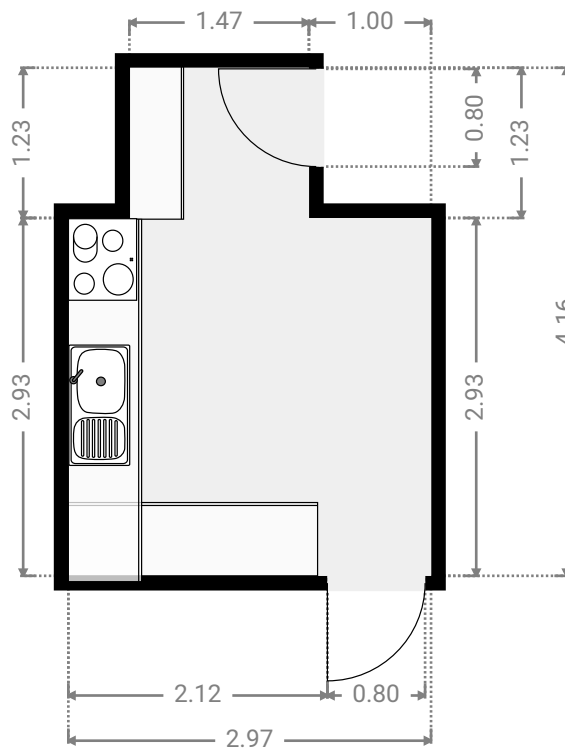
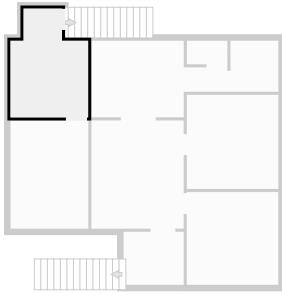

▼ Living Room
1st Floor

WIDTH: 2.30 m • LENGTH: 2.03 m
AREA: 4.67 m² • PERIMETER: 8.66 m

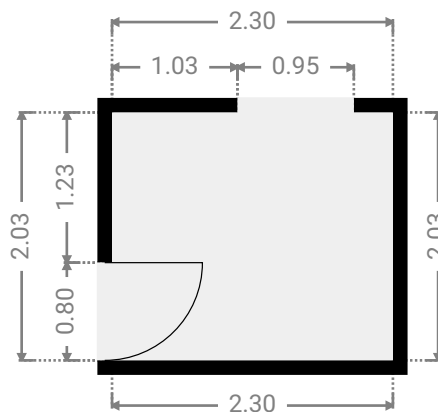
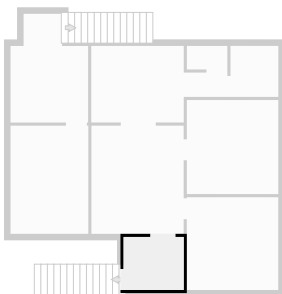

▼ **Living Room**
1st Floor

WIDTH: 3.53 m • LENGTH: 4.14 m
AREA: 14.61 m² • PERIMETER: 15.34 m

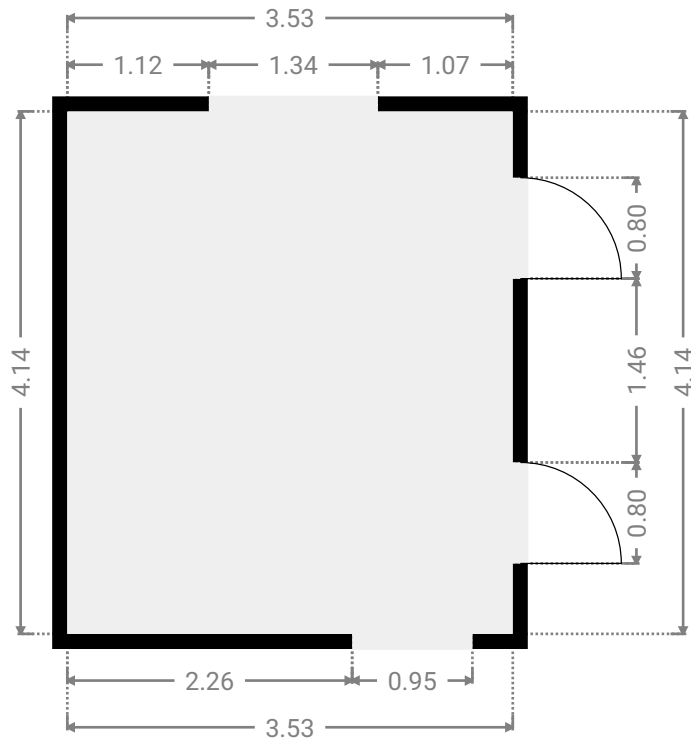
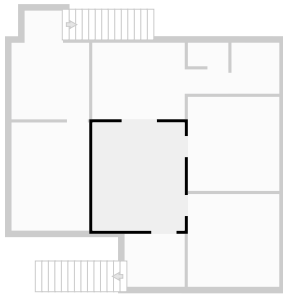

▼ **Toilet**
1st Floor

WIDTH: 1.55 m • LENGTH: 0.90 m
AREA: 1.40 m² • PERIMETER: 4.90 m

