

289 Eldon Street

SUBMITTED BY
Ray White Rockhampton Casey
stockers@cqoz.com

CREATED ON
2022-10-18

Floors
2

▼ Ground Floor

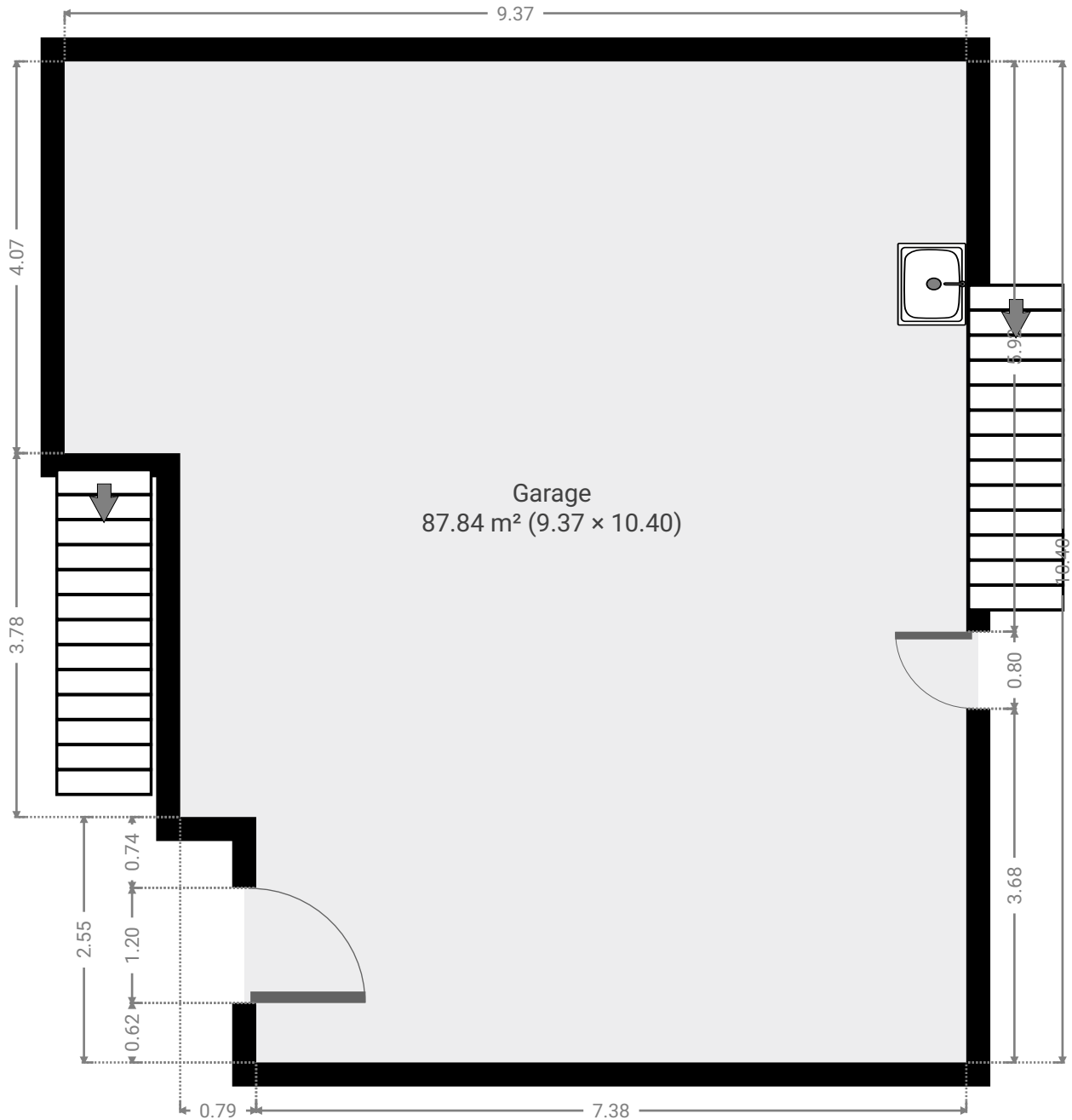

▼ **Garage**
Ground Floor

WIDTH: 10.40 m • LENGTH: 9.37 m
AREA: 87.84 m² • PERIMETER: 39.54 m

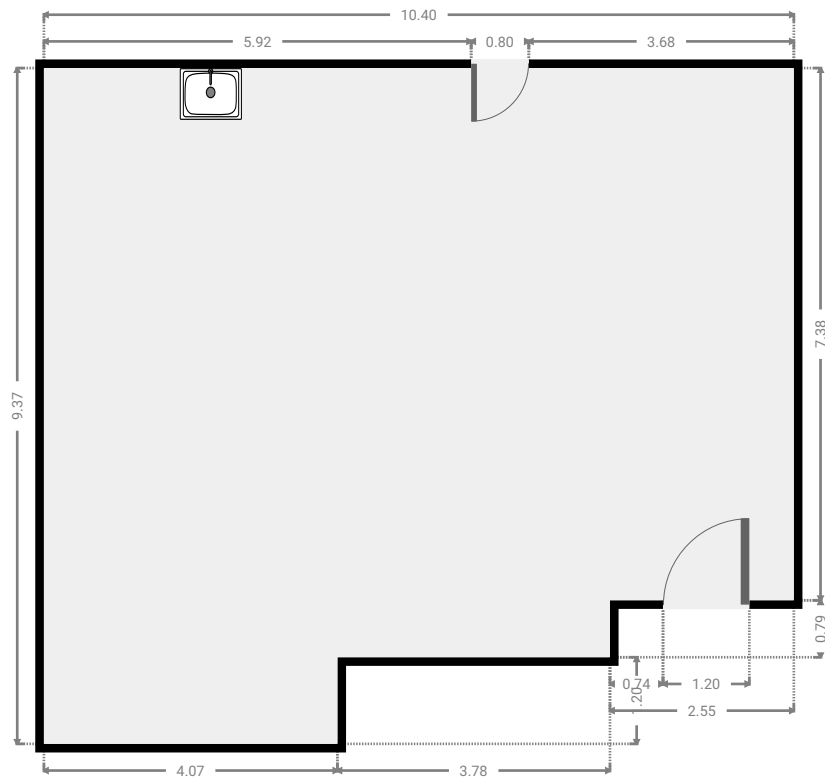
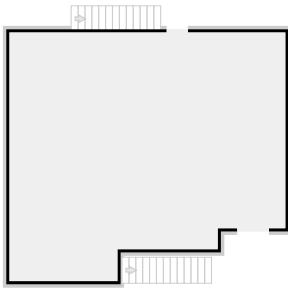

▼ 1st Floor



▼ **Bathroom**
1st Floor

WIDTH: 2.49 m • LENGTH: 1.54 m
AREA: 3.82 m² • PERIMETER: 8.04 m

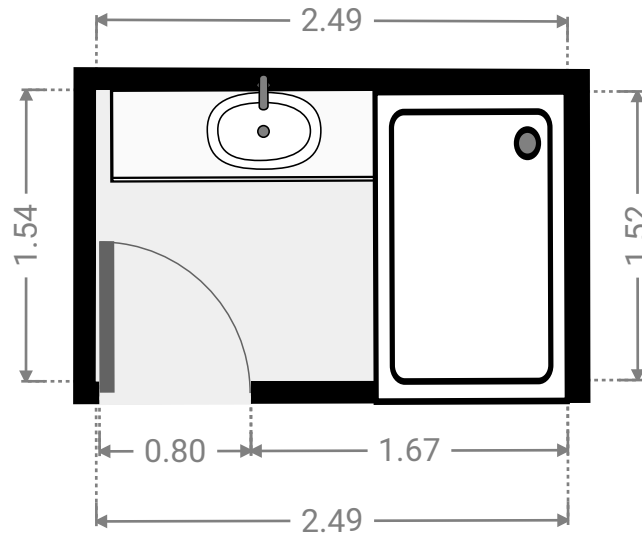
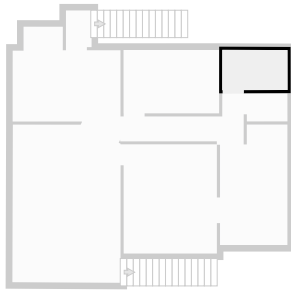

▼ **Bedroom**
1st Floor

WIDTH: 3.65 m • LENGTH: 2.42 m
AREA: 8.83 m² • PERIMETER: 12.14 m

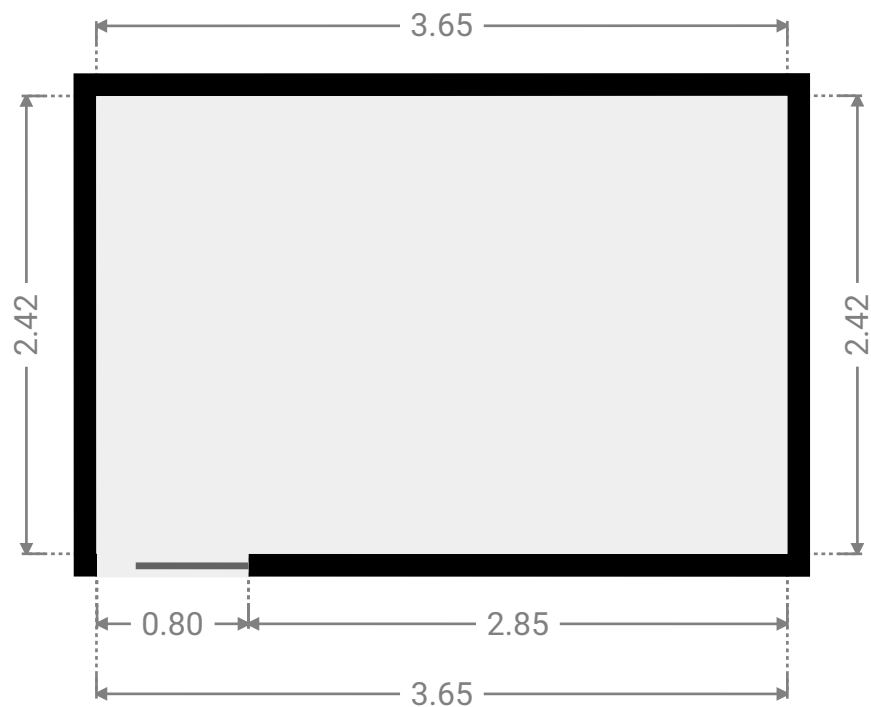
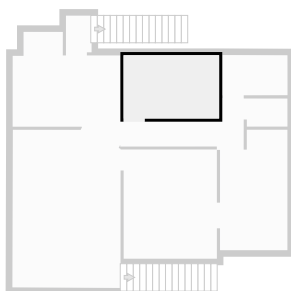

▼ **Bedroom**
1st Floor

WIDTH: 2.57 m • LENGTH: 4.60 m
AREA: 11.07 m² • PERIMETER: 14.35 m

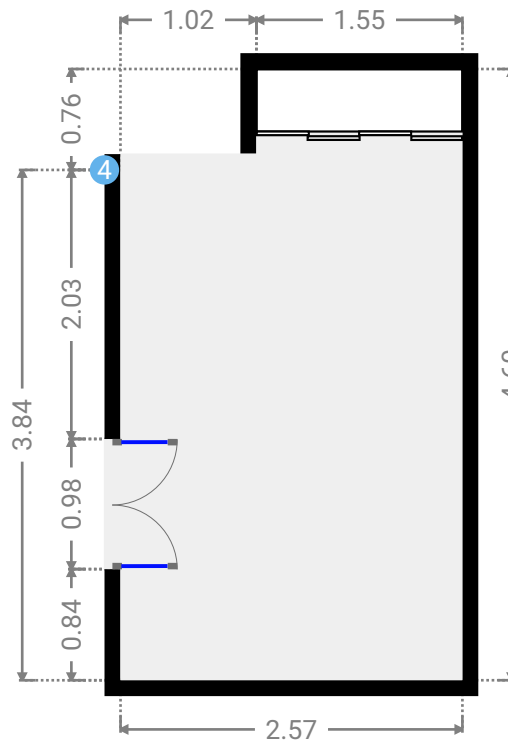
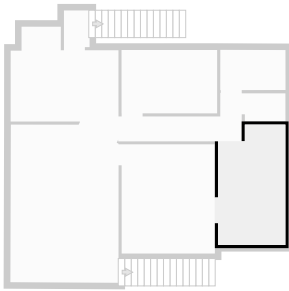

▼ **Bedroom/1st Floor**

4 OPENING

Height
0.00 m



▼ Hall
1st Floor

WIDTH: 4.59 m • LENGTH: 1.85 m
AREA: 5.09 m² • PERIMETER: 12.87 m

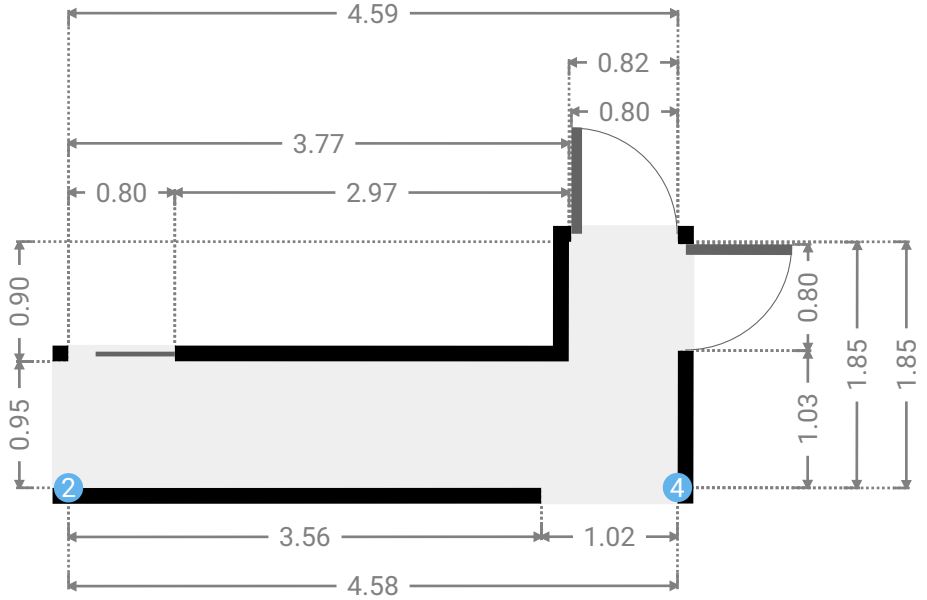
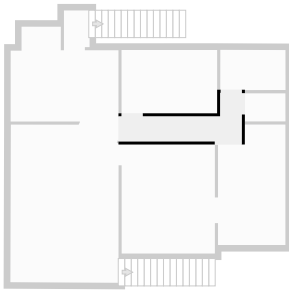

▼ Hall/1st Floor

2 OPENING

Height
0.00 m



▼ **Hall**
1st Floor

WIDTH: 0.98 m • LENGTH: 1.40 m
AREA: 1.37 m² • PERIMETER: 4.76 m

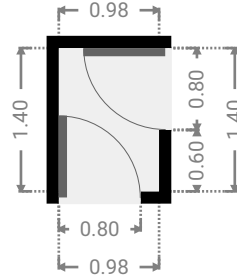
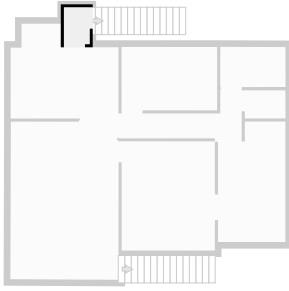

▼ **Kitchen**
1st Floor

WIDTH: 4.12 m • LENGTH: 4.33 m
AREA: 13.07 m² • PERIMETER: 16.34 m

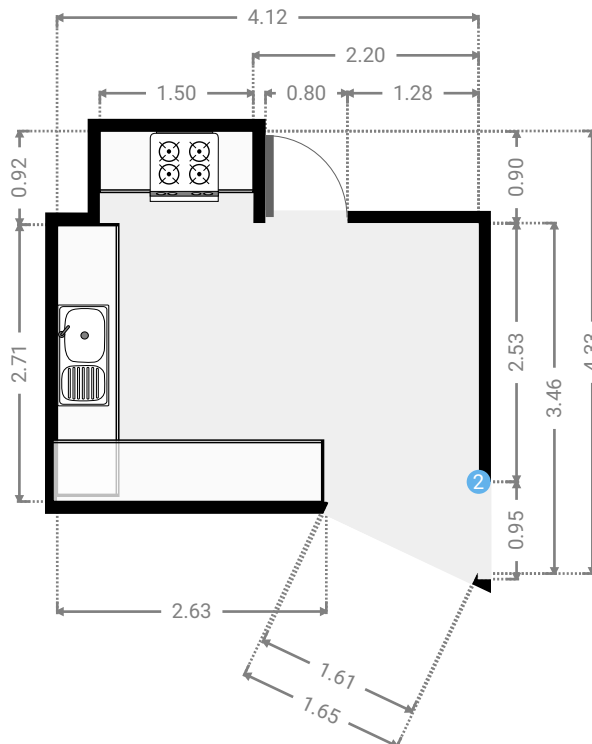
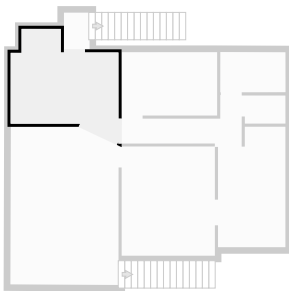

▼ **Living Room**
1st Floor

WIDTH: 4.13 m • LENGTH: 6.04 m
AREA: 24.30 m² • PERIMETER: 19.74 m

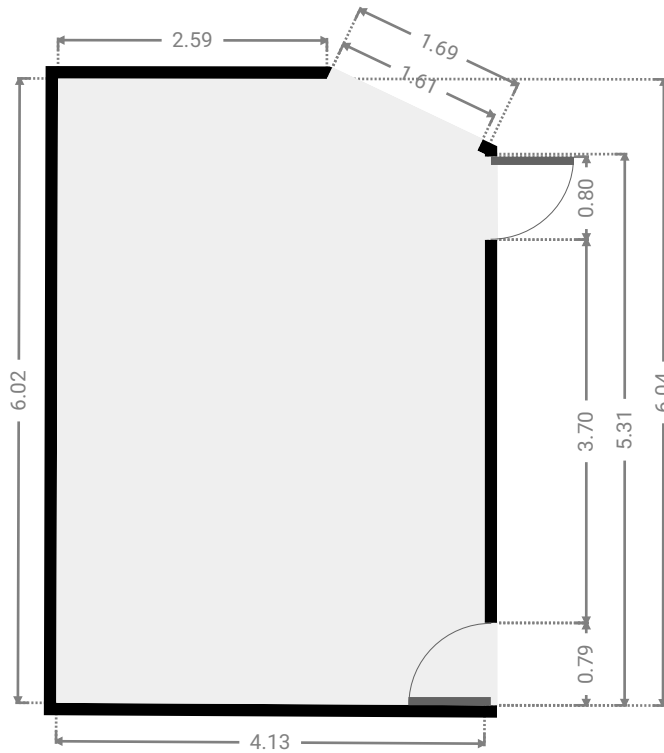
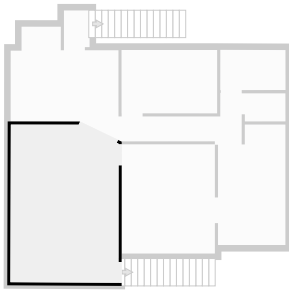

▼ **Primary Bedroom**
1st Floor

WIDTH: 3.56 m • LENGTH: 4.17 m
AREA: 14.85 m² • PERIMETER: 15.46 m

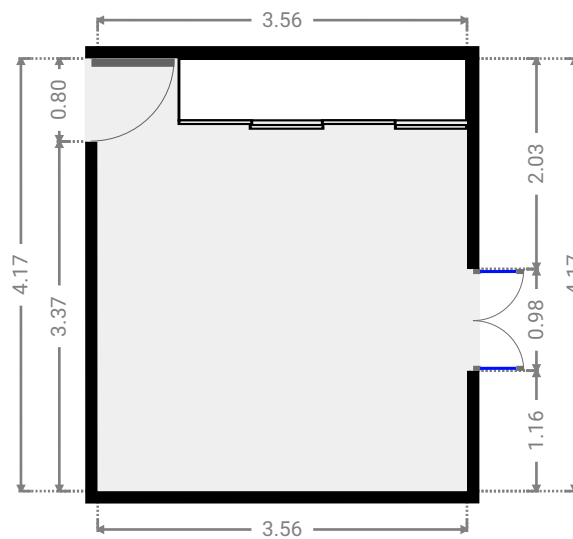
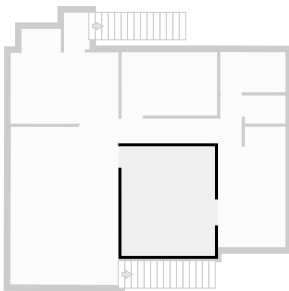

▼ Toilet
1st Floor

WIDTH: 1.55 m • LENGTH: 1.07 m
AREA: 1.66 m² • PERIMETER: 5.24 m

