

285 Dawbarn Street

SUBMITTED BY

Ray White Rockhampton Casey
stockers@cqoz.com

CREATED ON

2022-05-11

Floors

2

▼ Ground Floor

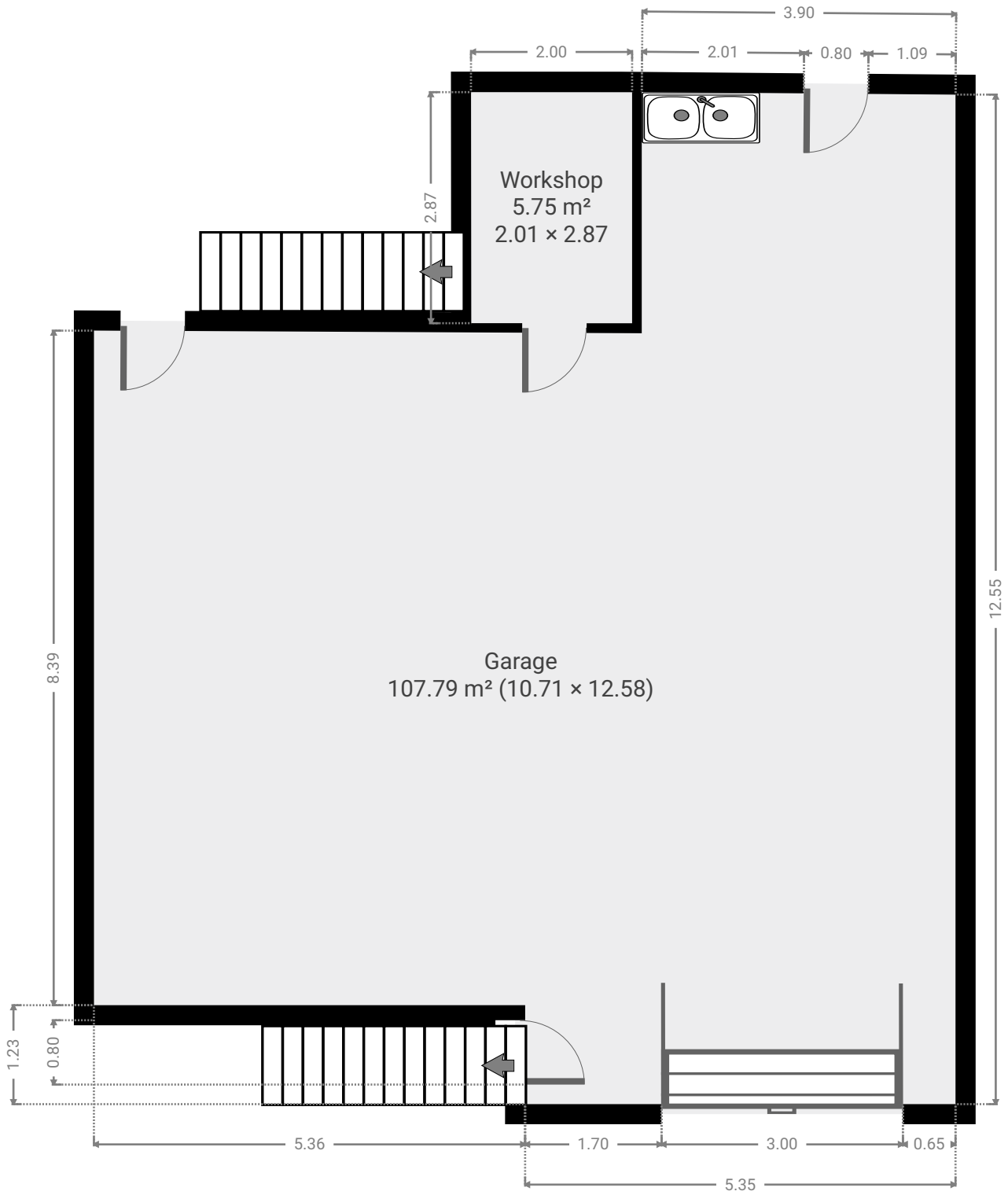

▼ **Garage**
Ground Floor

WIDTH: 10.71 m • LENGTH: 12.58 m
AREA: 107.79 m² • PERIMETER: 46.59 m

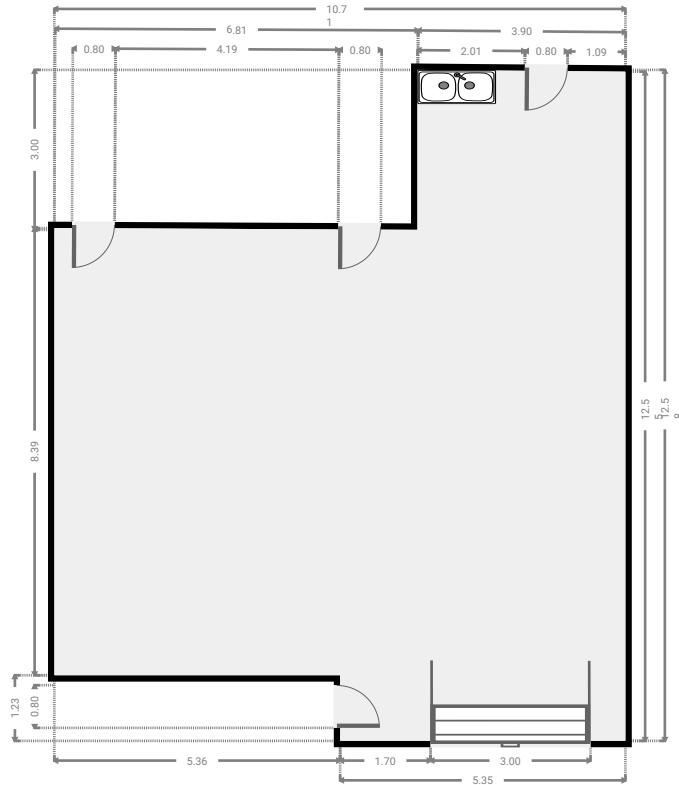
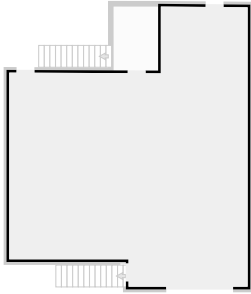

▼ **Workshop**
Ground Floor

WIDTH: 2.01 m • LENGTH: 2.87 m
AREA: 5.75 m² • PERIMETER: 9.75 m

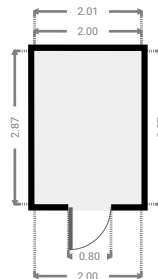
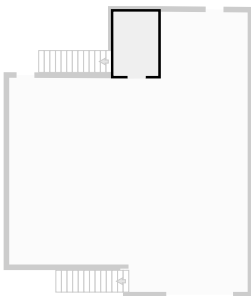

▼ 1st Floor

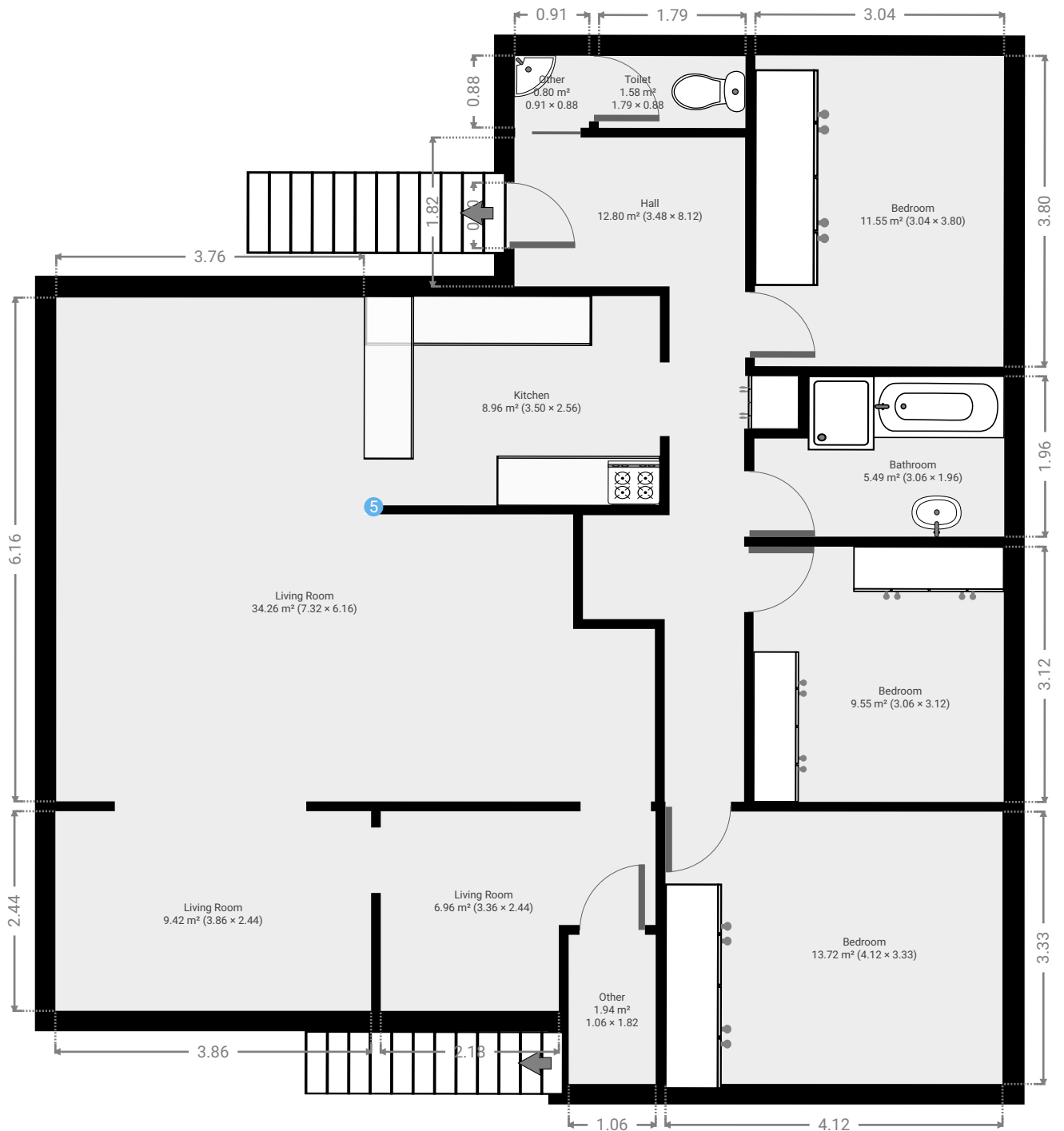

▼ **Bathroom**
1st Floor

WIDTH: 3.06 m • LENGTH: 1.96 m
AREA: 5.49 m² • PERIMETER: 10.03 m

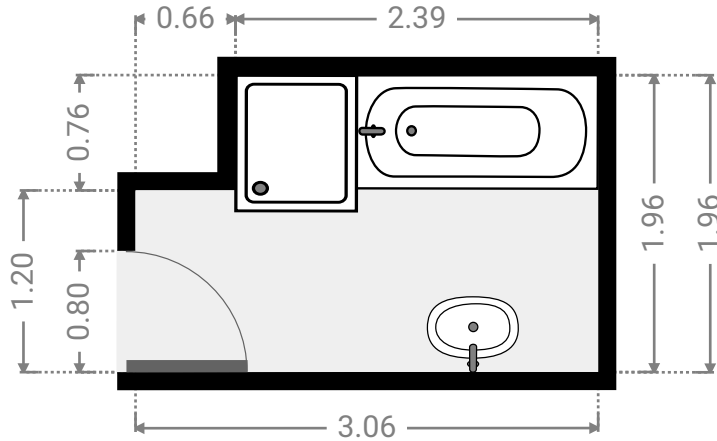
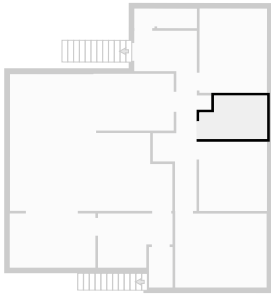

▼ **Bedroom**
1st Floor

WIDTH: 3.04 m • LENGTH: 3.80 m
AREA: 11.55 m² • PERIMETER: 13.68 m

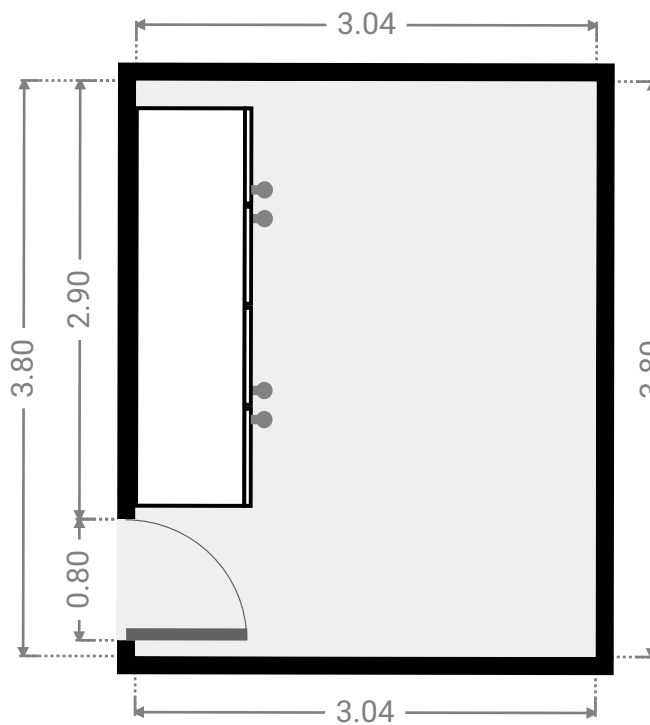
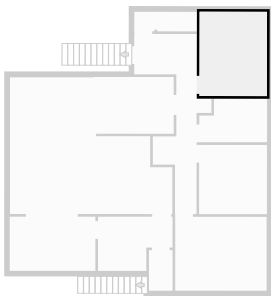

▼ **Bedroom**
1st Floor

WIDTH: 3.06 m • LENGTH: 3.12 m
AREA: 9.55 m² • PERIMETER: 12.36 m

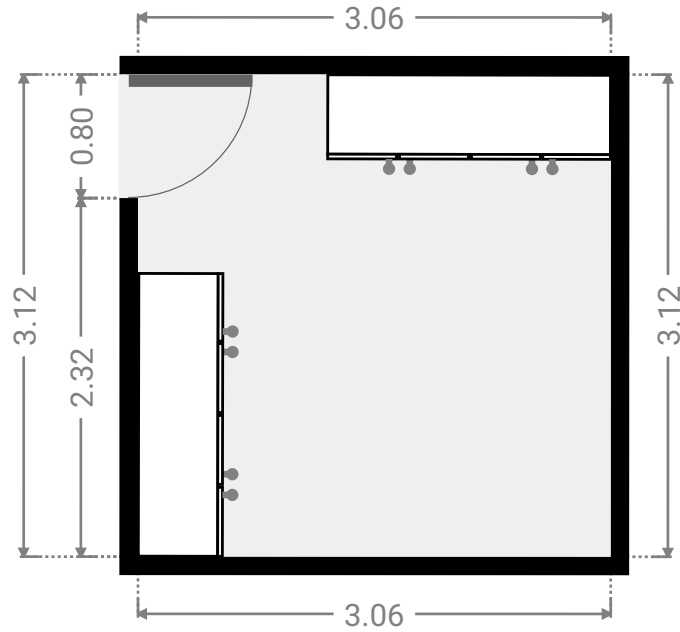
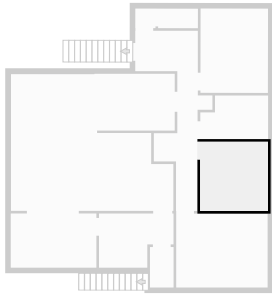

▼ **Bedroom**
1st Floor

WIDTH: 4.12 m • LENGTH: 3.33 m
AREA: 13.72 m² • PERIMETER: 14.90 m

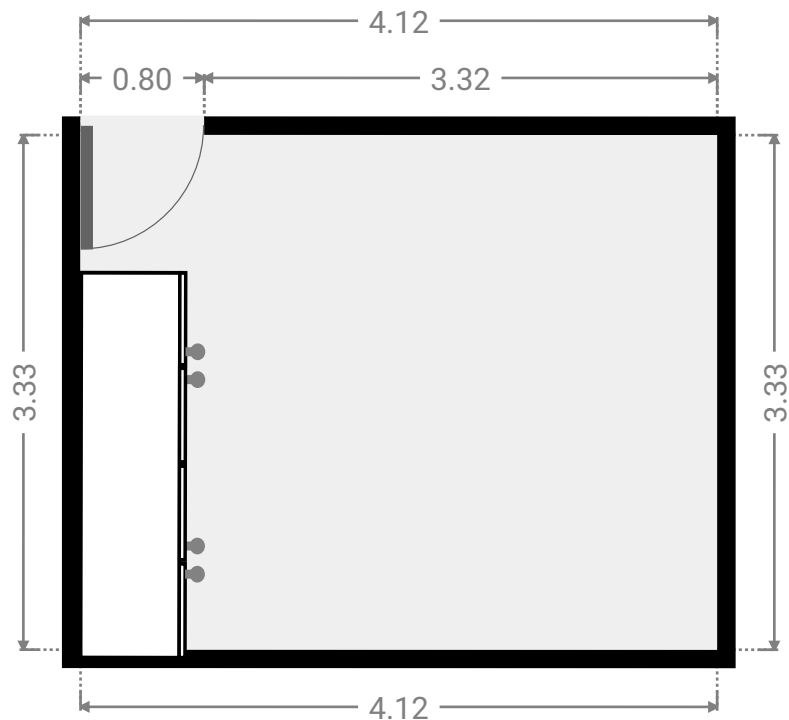
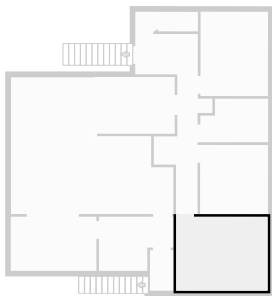

▼ Hall
1st Floor

WIDTH: 3.48 m • LENGTH: 8.12 m
AREA: 12.80 m² • PERIMETER: 25.31 m

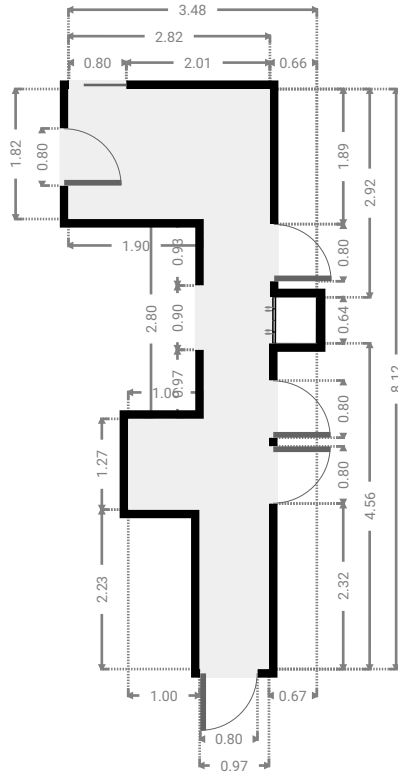
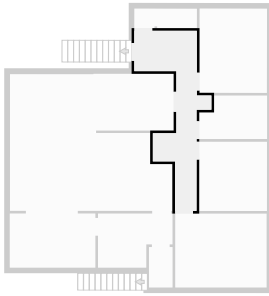

▼ Kitchen
1st Floor

WIDTH: 3.50 m • LENGTH: 2.56 m
AREA: 8.96 m² • PERIMETER: 12.12 m

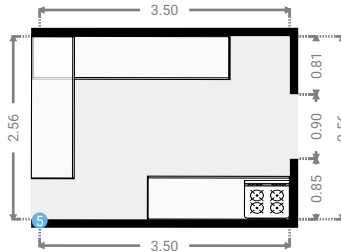
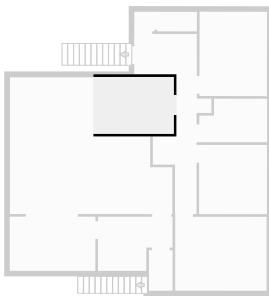

▼ **Kitchen/1st Floor**

5 **OPENING**

Height
0.00 m



▼ **Living Room**
1st Floor

WIDTH: 3.36 m • LENGTH: 2.44 m
AREA: 6.96 m² • PERIMETER: 11.60 m

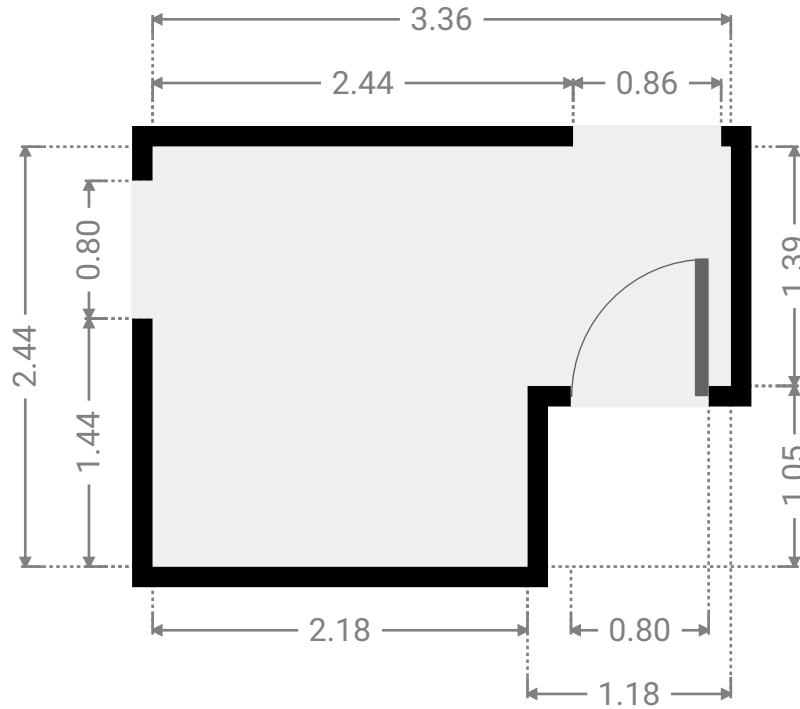
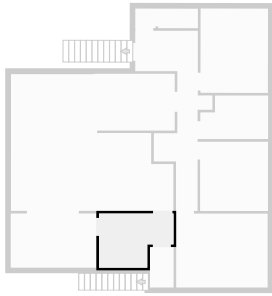

▼ **Living Room**
1st Floor

WIDTH: 3.86 m • LENGTH: 2.44 m
AREA: 9.42 m² • PERIMETER: 12.60 m

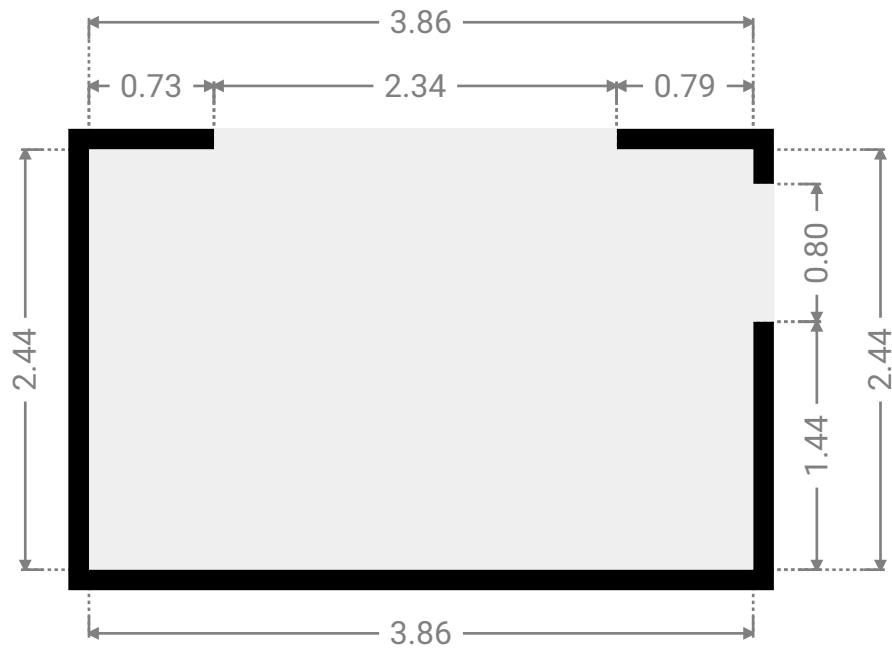
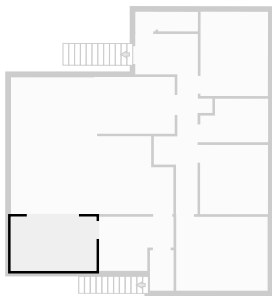

▼ **Living Room**
1st Floor

WIDTH: 7.32 m • LENGTH: 6.16 m
AREA: 34.26 m² • PERIMETER: 26.96 m

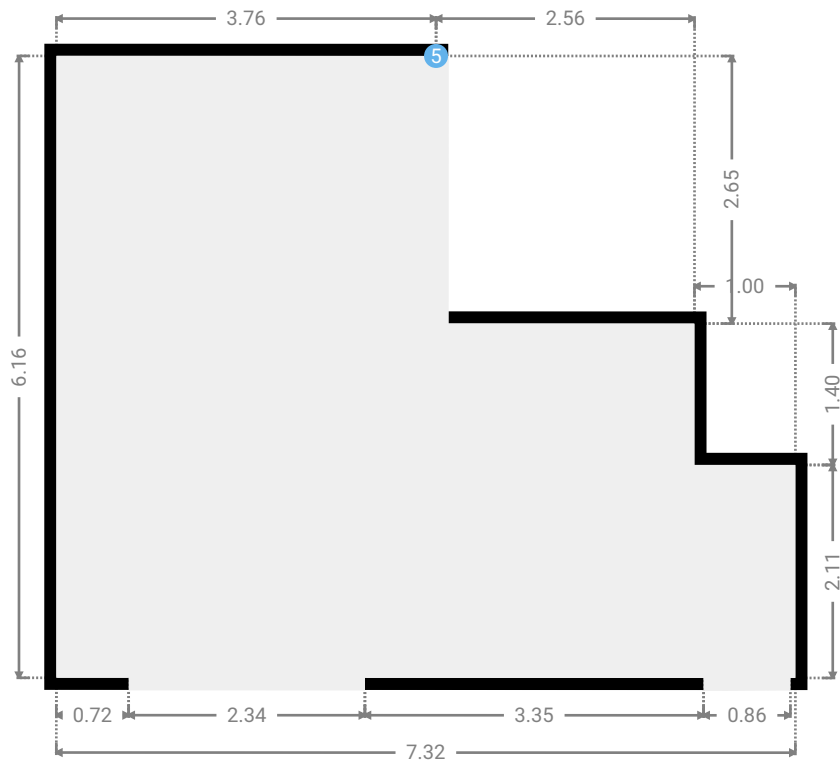
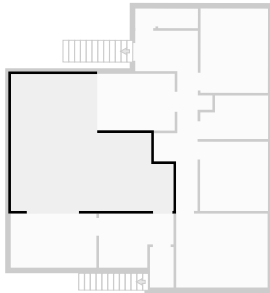

▼ **Other**
1st Floor

WIDTH: 0.91 m • LENGTH: 0.88 m
AREA: 0.80 m² • PERIMETER: 3.58 m

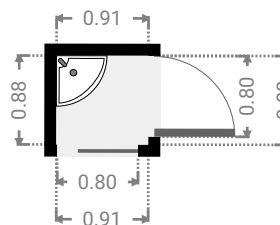
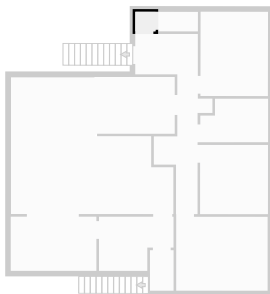

▼ **Other**
1st Floor

WIDTH: 1.06 m • LENGTH: 1.82 m
AREA: 1.94 m² • PERIMETER: 5.78 m

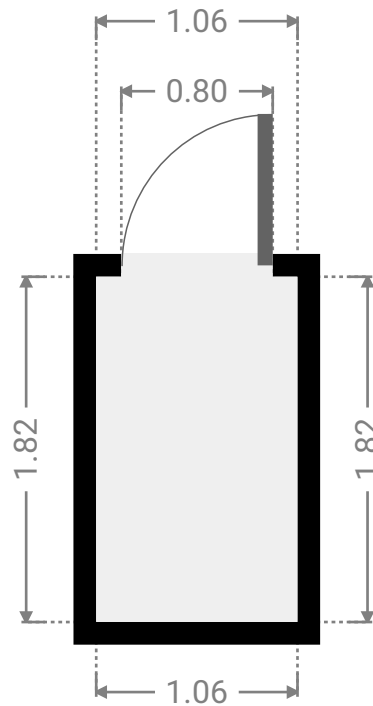
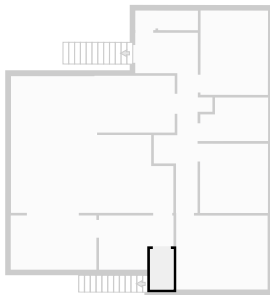

▼ **Toilet**
1st Floor

WIDTH: 1.79 m • LENGTH: 0.88 m
AREA: 1.58 m² • PERIMETER: 5.34 m

