

285 Berseker Street

SUBMITTED BY
Ray White Rockhampton Casey
stockers@cqoz.com

CREATED ON
2022-05-05

Floors
2

▼ Ground Floor

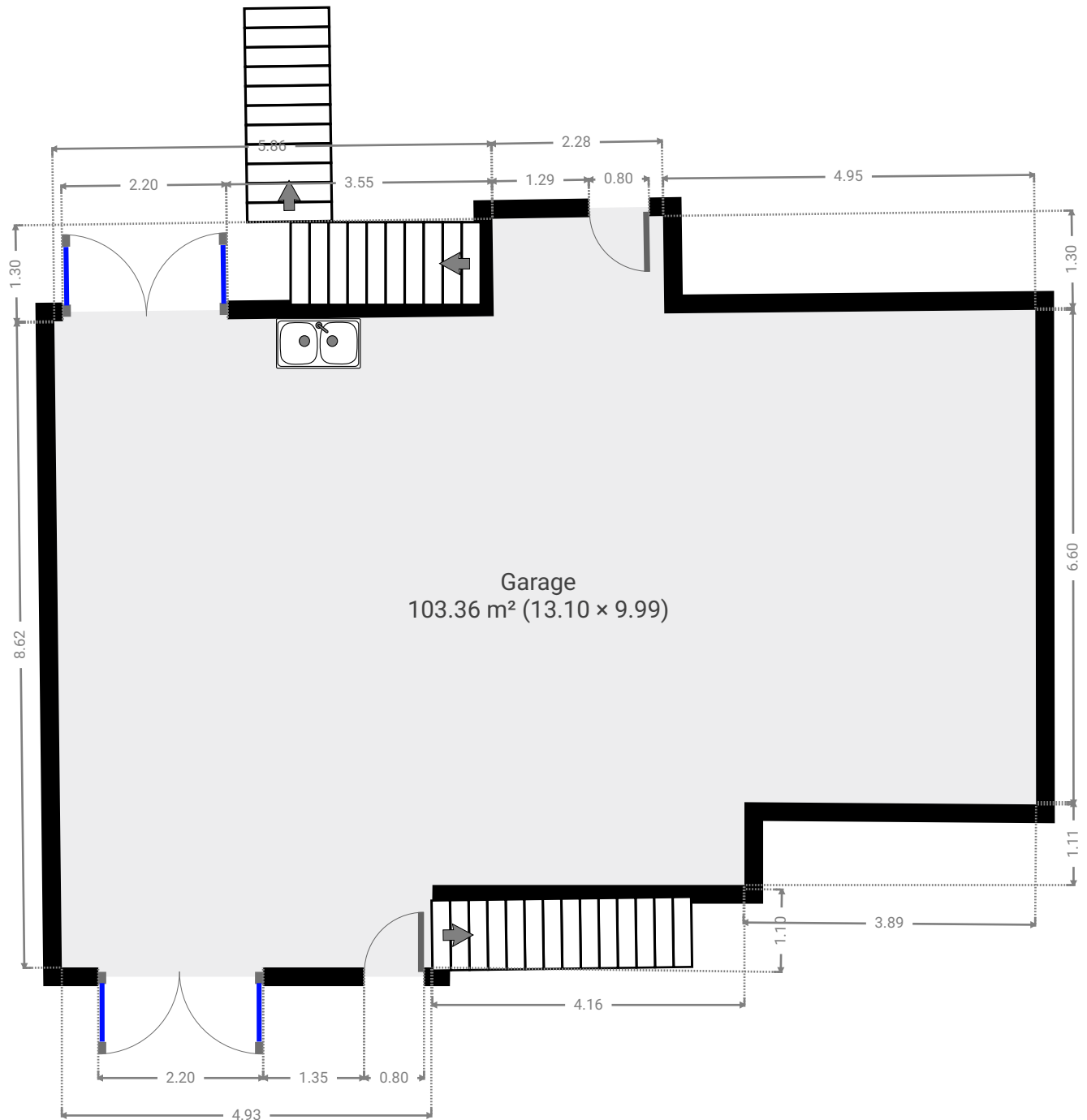

▼ **Garage**
Ground Floor

WIDTH: 13.10 m • LENGTH: 9.99 m
AREA: 103.36 m² • PERIMETER: 46.10 m

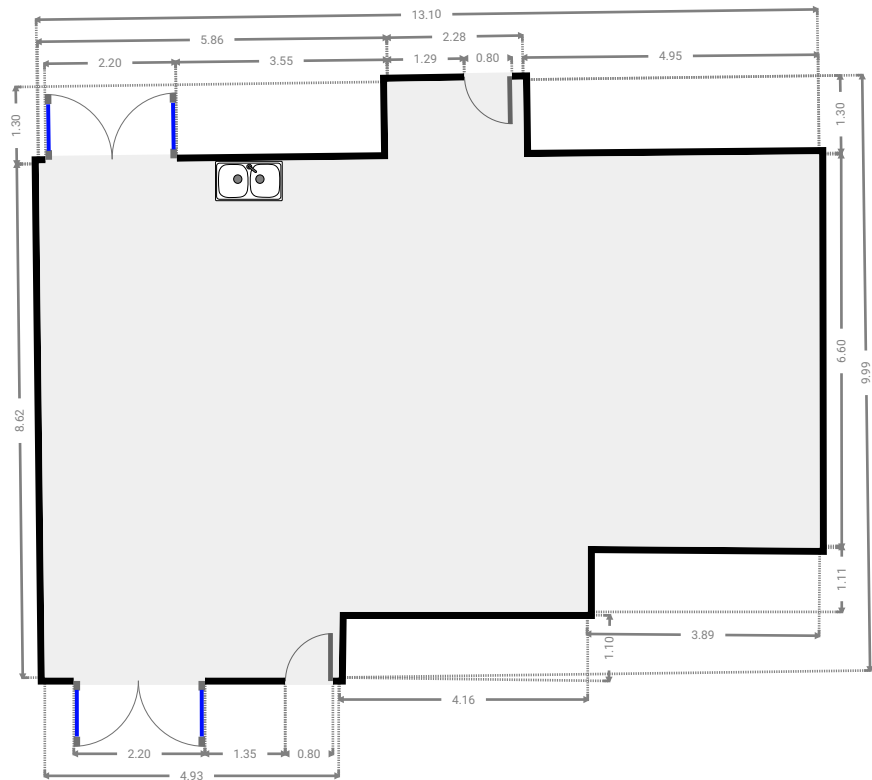
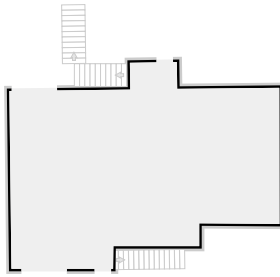

▼ 1st Floor

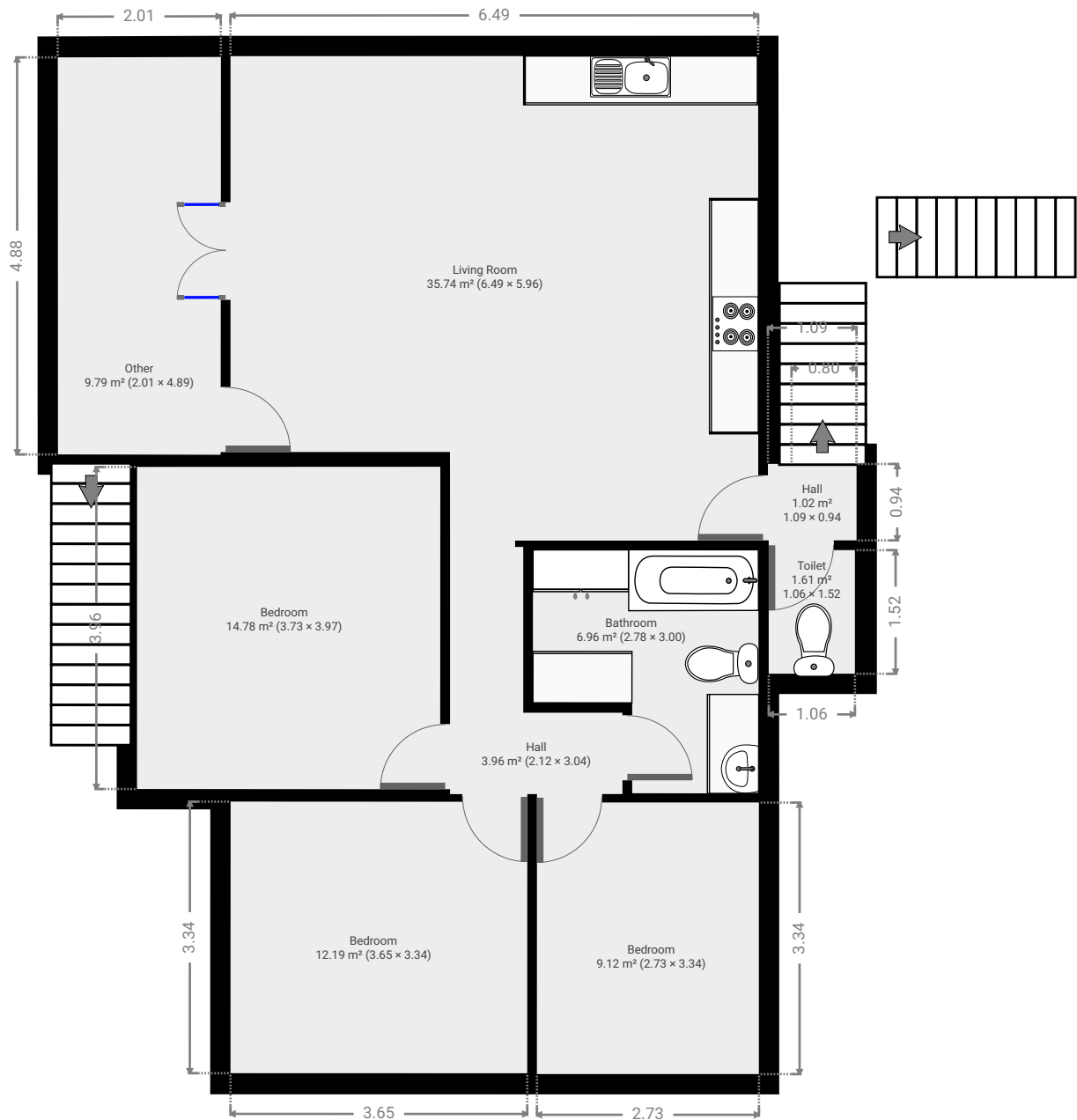

▼ **Living Room**
1st Floor

WIDTH: 5.96 m • LENGTH: 6.49 m
AREA: 35.74 m² • PERIMETER: 24.90 m

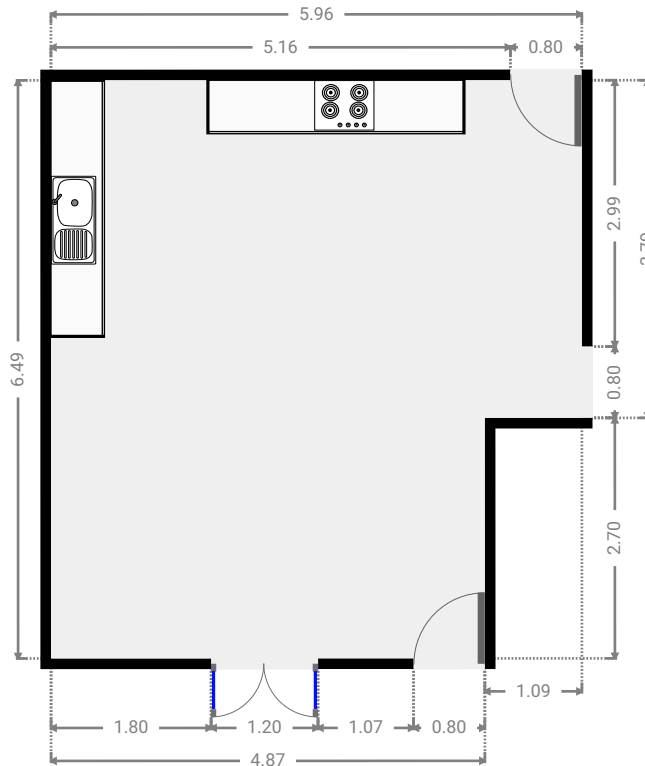

▼ **Hall**
1st Floor

WIDTH: 3.04 m • LENGTH: 2.12 m
AREA: 3.96 m² • PERIMETER: 10.32 m

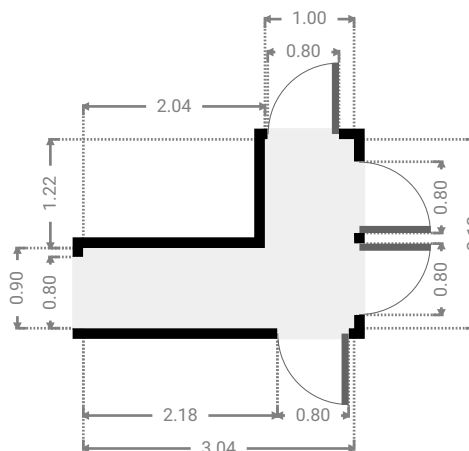
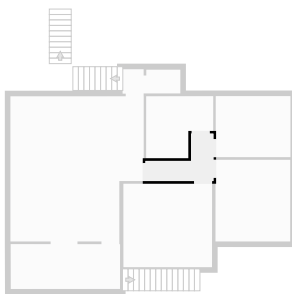

▼ **Bedroom**
1st Floor

WIDTH: 3.97 m • LENGTH: 3.73 m
AREA: 14.78 m² • PERIMETER: 15.39 m

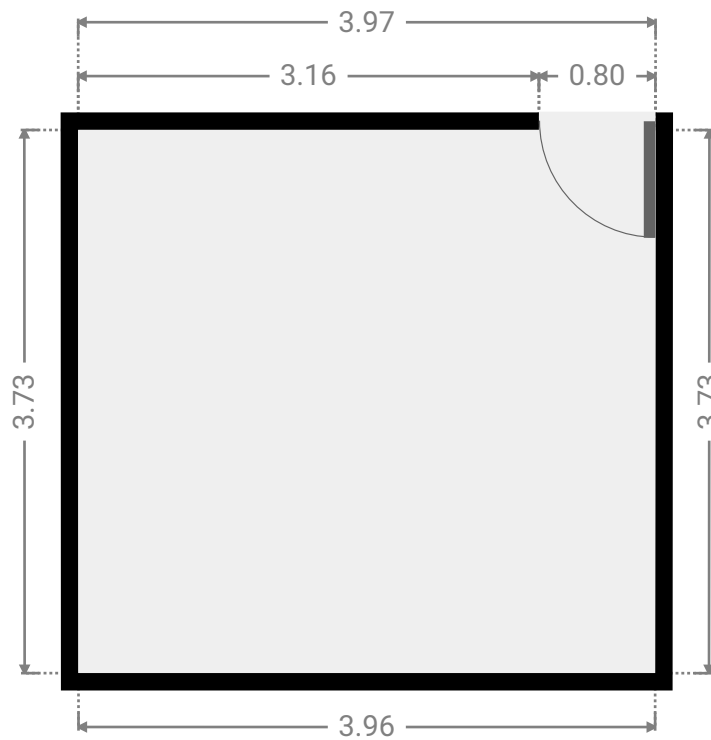
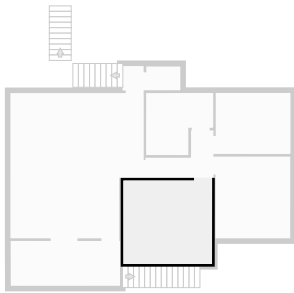

▼ **Bedroom**
1st Floor

WIDTH: 3.34 m • LENGTH: 3.65 m
AREA: 12.19 m² • PERIMETER: 13.98 m

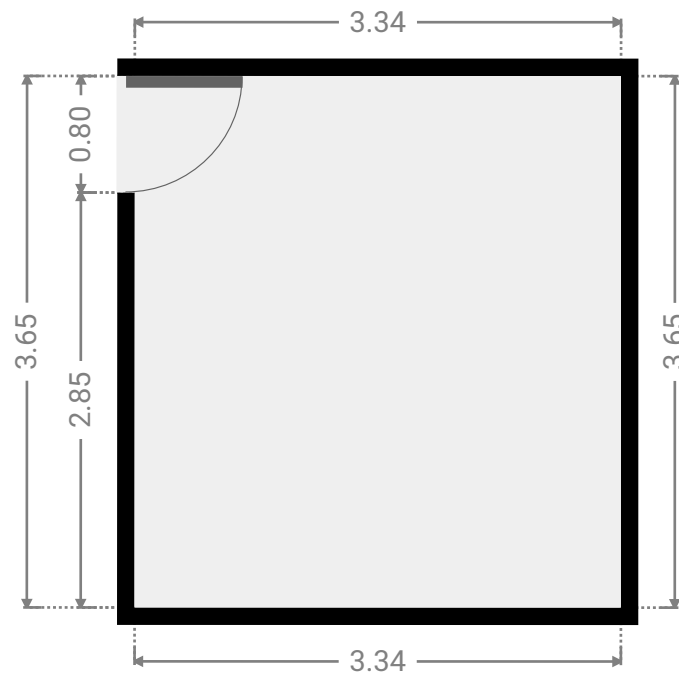
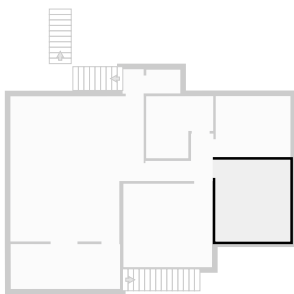

▼ **Bedroom**
1st Floor

WIDTH: 3.34 m • LENGTH: 2.73 m
AREA: 9.12 m² • PERIMETER: 12.14 m

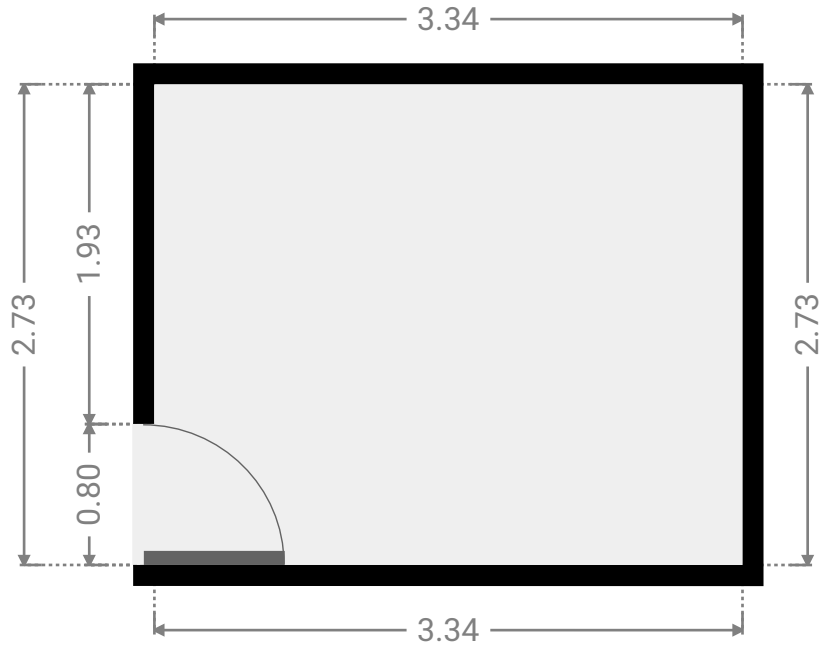
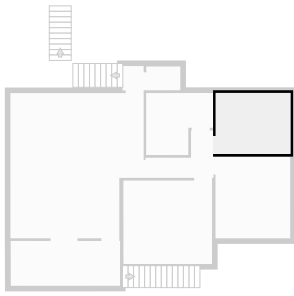

▼ **Bathroom**
1st Floor

WIDTH: 3.00 m • LENGTH: 2.78 m
AREA: 6.96 m² • PERIMETER: 11.54 m

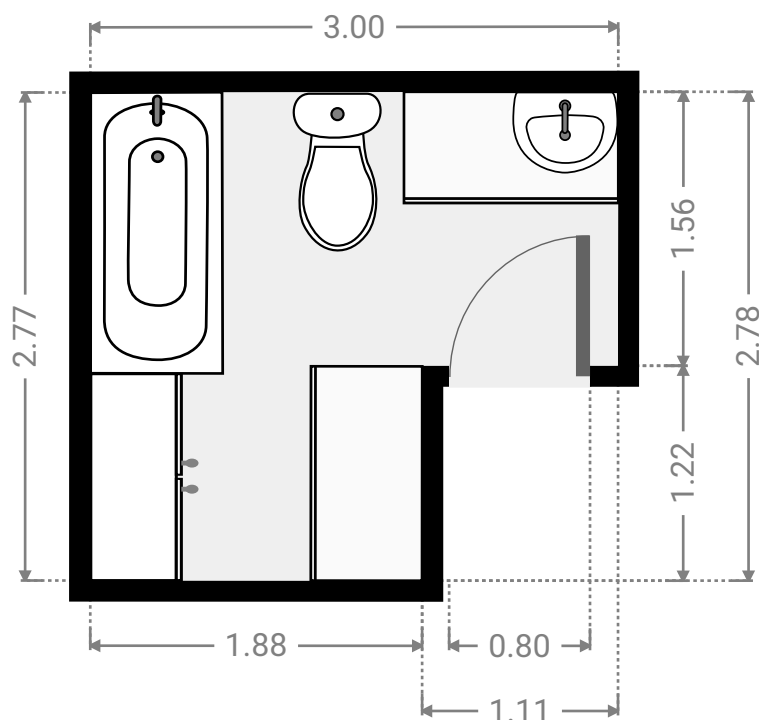
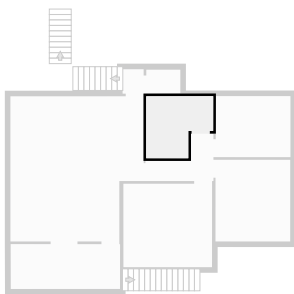

▼ **Hall**
1st Floor

WIDTH: 0.94 m • LENGTH: 1.09 m
AREA: 1.02 m² • PERIMETER: 4.06 m

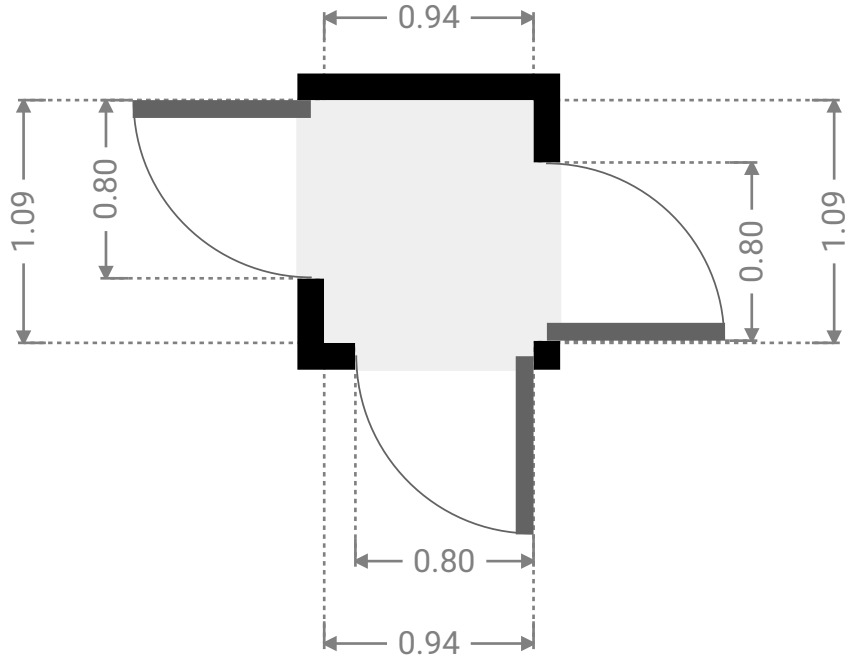

▼ **Toilet**
1st Floor

WIDTH: 1.52 m • LENGTH: 1.06 m
AREA: 1.61 m² • PERIMETER: 5.16 m

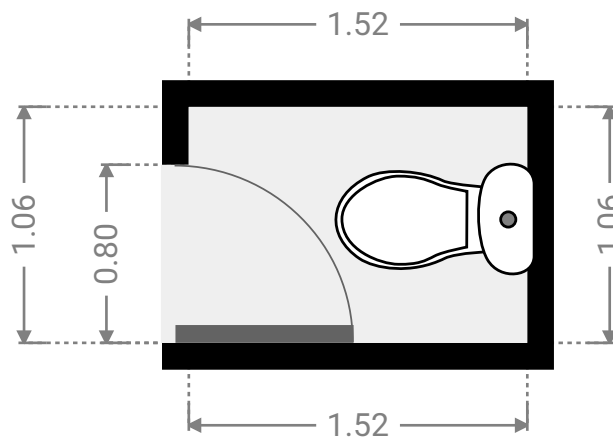

▼ Other
1st Floor

WIDTH: 4.89 m • LENGTH: 2.01 m
AREA: 9.79 m² • PERIMETER: 13.78 m

