

281 Halford Street

SUBMITTED BY
Janelle Casey

CREATED ON
2021-10-07

Floors
2

▼ Ground Floor

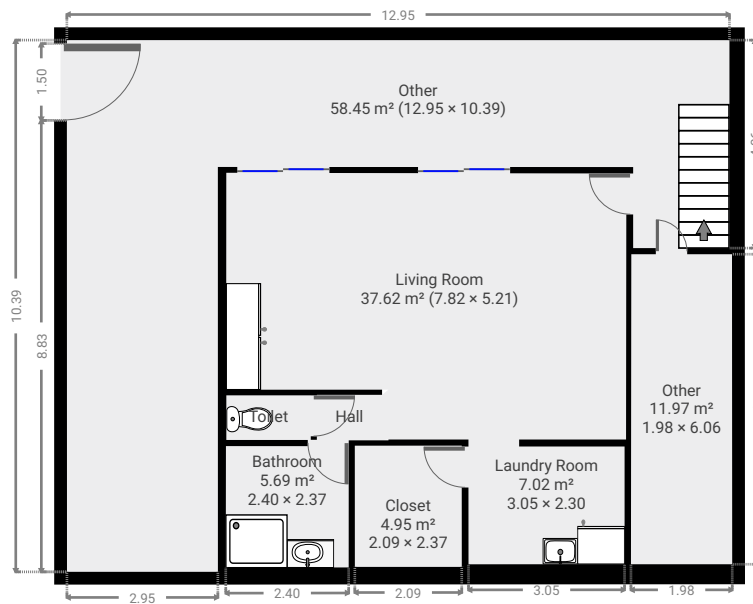
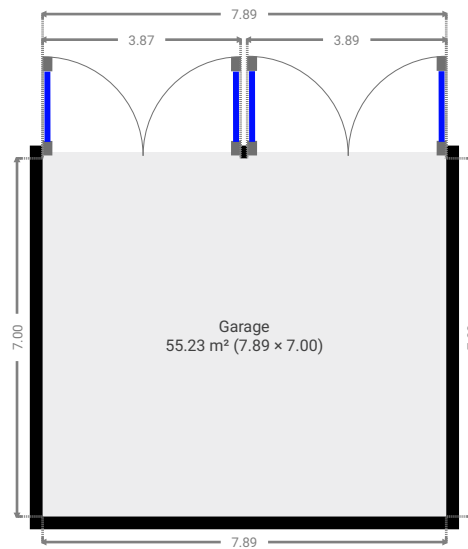

▼ Living Room
Ground Floor

WIDTH: 7.82 m • LENGTH: 5.21 m
AREA: 37.62 m² • PERIMETER: 26.05 m

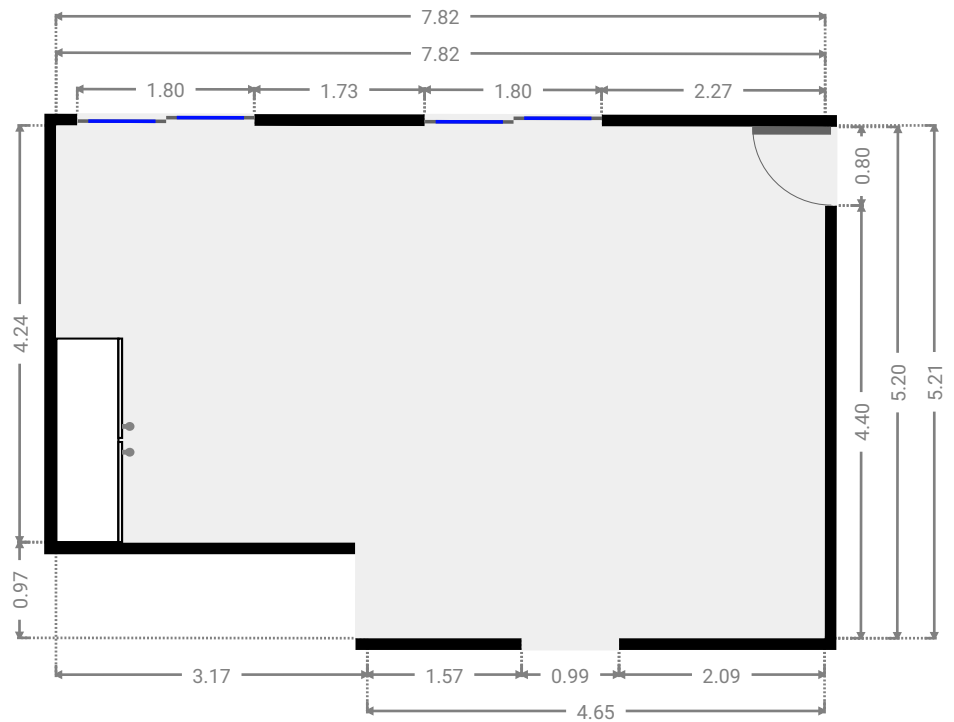
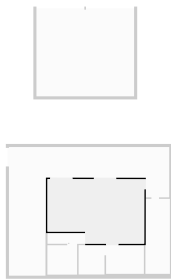

▼ Laundry Room
Ground Floor

WIDTH: 3.05 m • LENGTH: 2.30 m
AREA: 7.02 m² • PERIMETER: 10.70 m

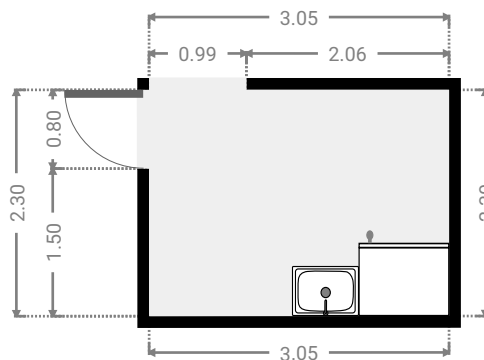
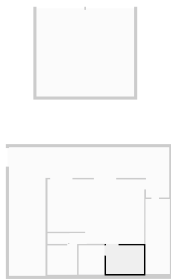

▼ **Closet**
Ground Floor

WIDTH: 2.09 m • LENGTH: 2.37 m
AREA: 4.95 m² • PERIMETER: 8.92 m

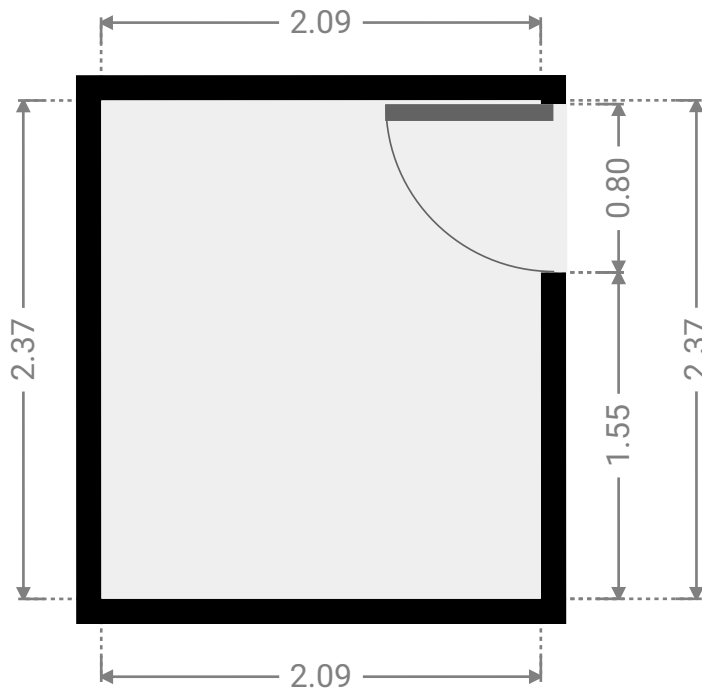
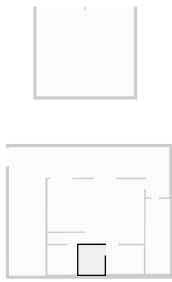

▼ **Hall**
Ground Floor

WIDTH: 1.28 m • LENGTH: 0.89 m
AREA: 1.14 m² • PERIMETER: 4.34 m

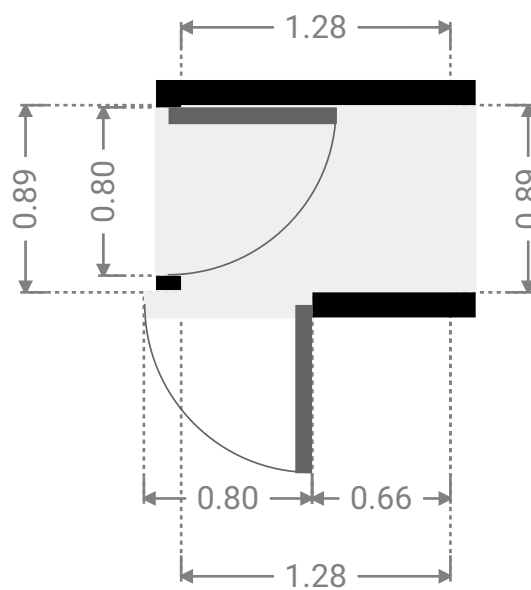
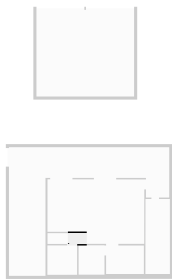

▼ **Toilet**
Ground Floor

WIDTH: 1.65 m • LENGTH: 0.87 m
AREA: 1.44 m² • PERIMETER: 5.05 m

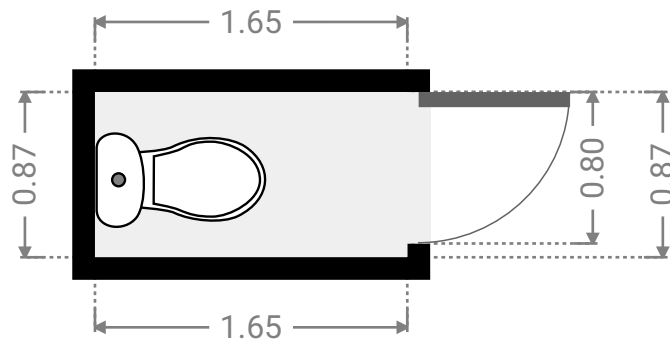
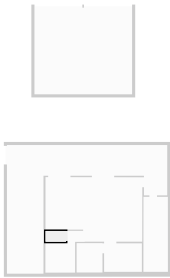

▼ **Bathroom**
Ground Floor

WIDTH: 2.40 m • LENGTH: 2.37 m
AREA: 5.69 m² • PERIMETER: 9.55 m

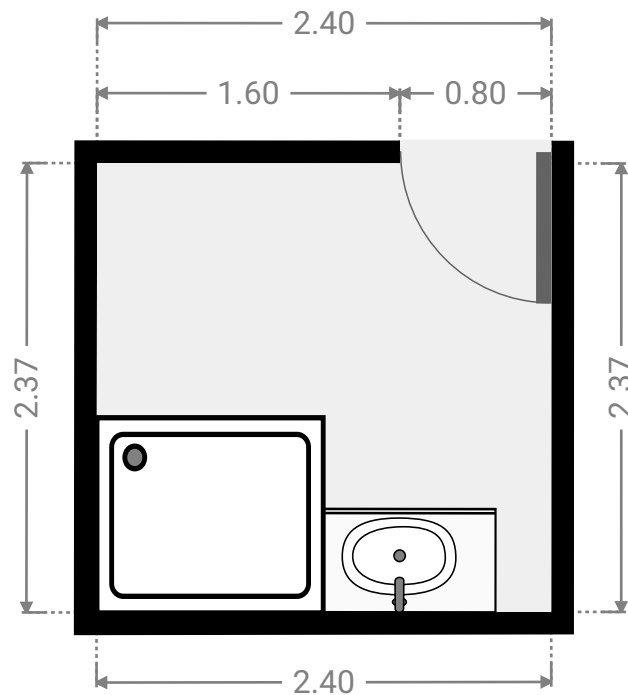
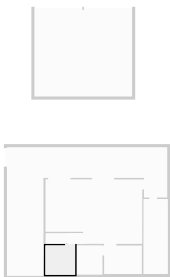

▼ **Garage**
Ground Floor

WIDTH: 7.89 m • LENGTH: 7.00 m
AREA: 55.23 m² • PERIMETER: 29.78 m

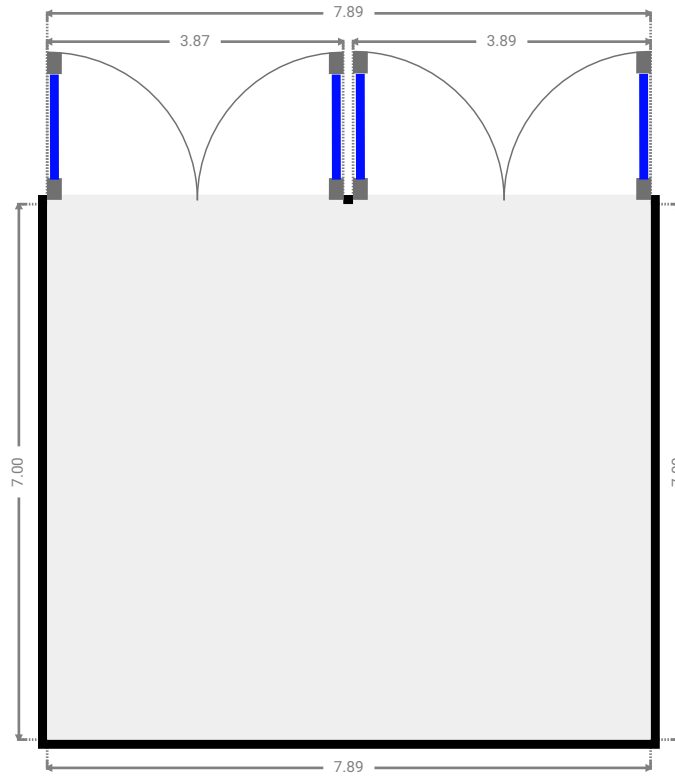
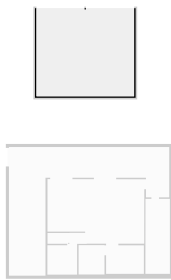

▼ 1st Floor

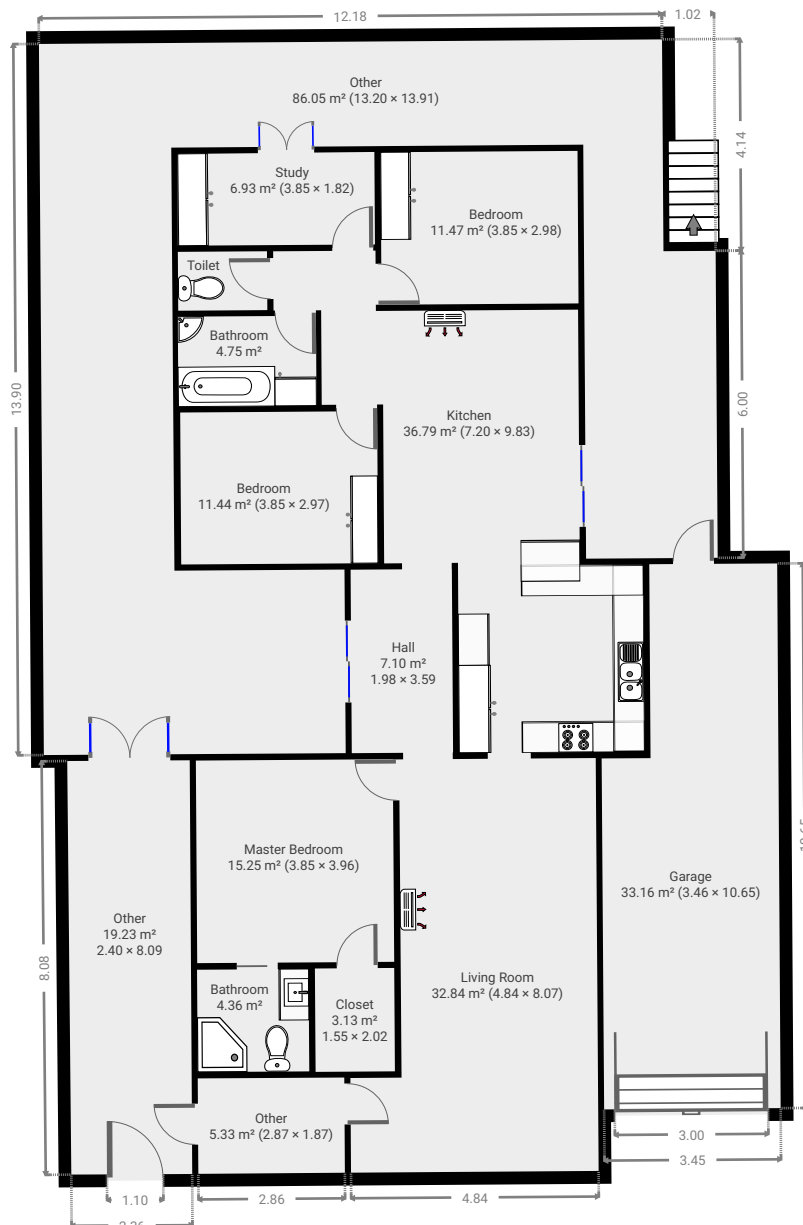
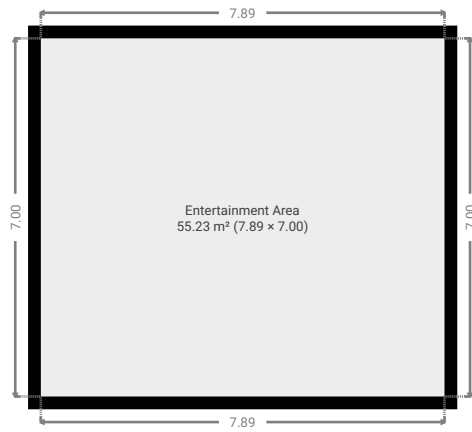

▼ Living Room
1st Floor

WIDTH: 4.84 m • LENGTH: 8.07 m
AREA: 32.84 m² • PERIMETER: 25.82 m

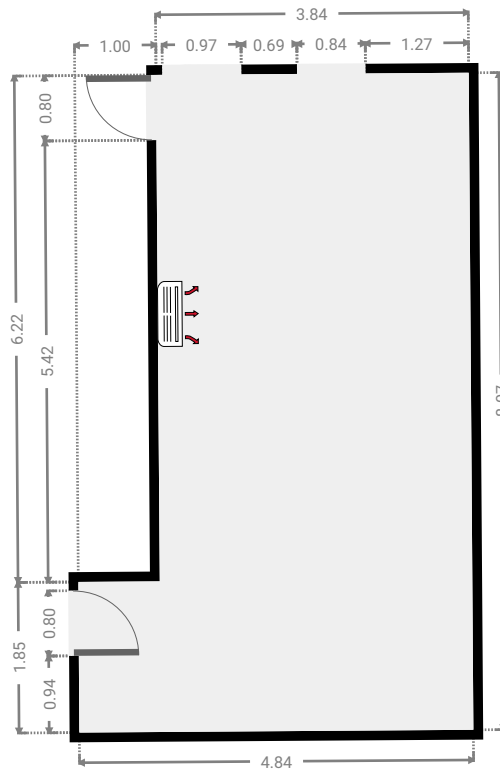

▼ Master Bedroom
1st Floor

WIDTH: 3.85 m • LENGTH: 3.96 m
AREA: 15.25 m² • PERIMETER: 15.62 m

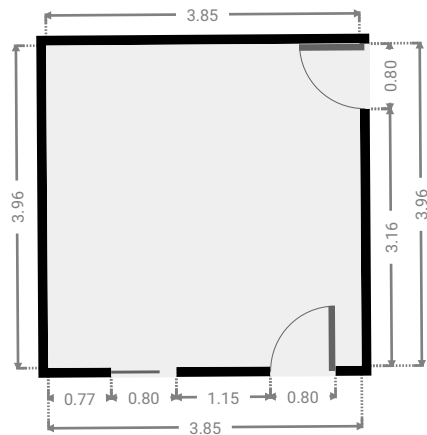

▼ **Closet**
1st Floor

WIDTH: 1.55 m • LENGTH: 2.02 m
AREA: 3.13 m² • PERIMETER: 7.14 m

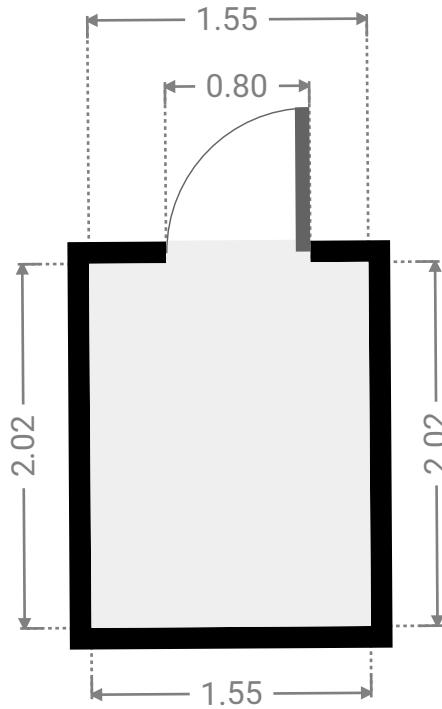

▼ **Bathroom**
1st Floor

WIDTH: 2.18 m • LENGTH: 2.00 m
AREA: 4.36 m² • PERIMETER: 8.36 m

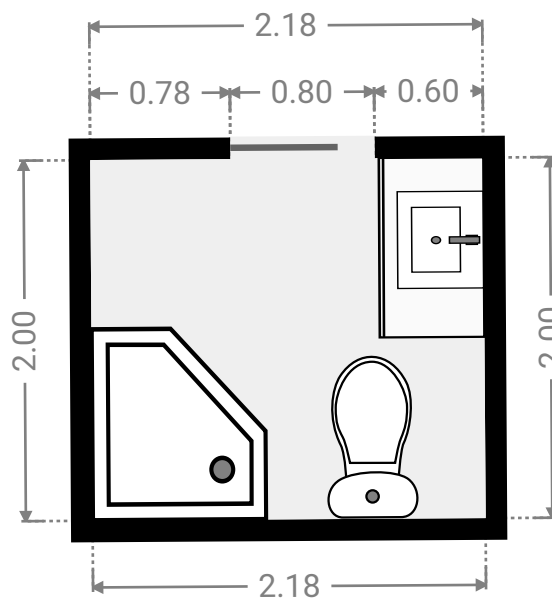

▼ **Hall**
1st Floor

WIDTH: 1.98 m • LENGTH: 3.59 m
AREA: 7.10 m² • PERIMETER: 11.13 m

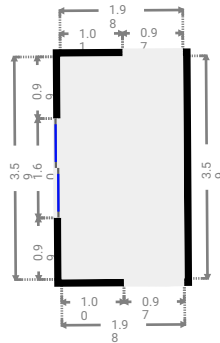

▼ **Kitchen**
1st Floor

WIDTH: 7.20 m • LENGTH: 9.83 m
AREA: 36.79 m² • PERIMETER: 34.05 m

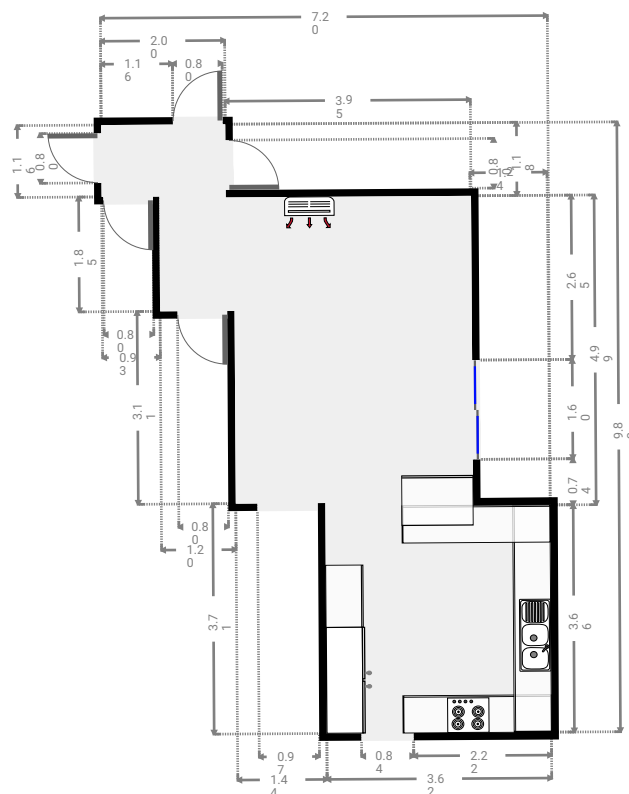
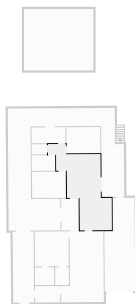

▼ **Bedroom**
1st Floor

WIDTH: 3.85 m • LENGTH: 2.97 m
AREA: 11.44 m² • PERIMETER: 13.64 m

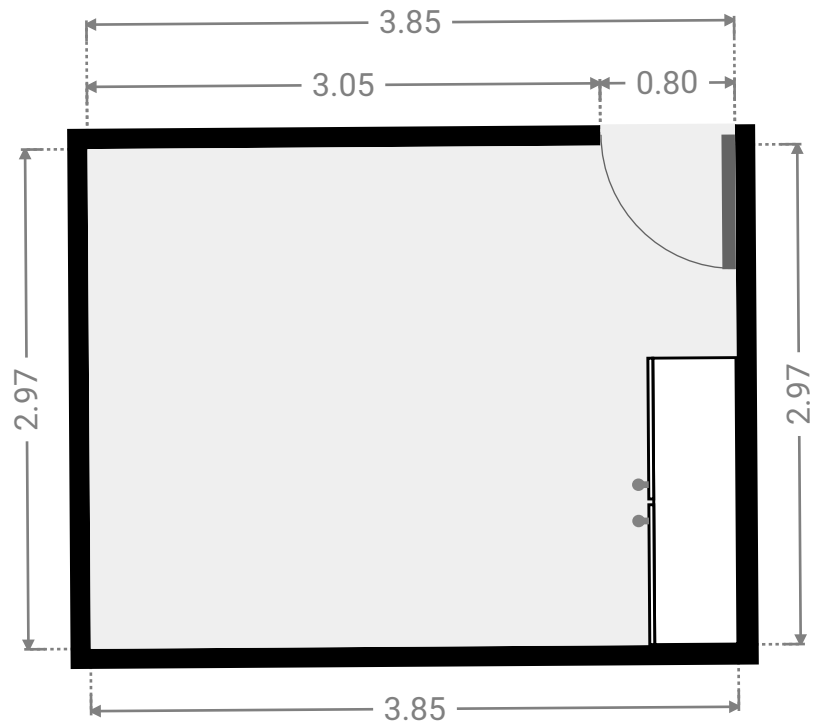
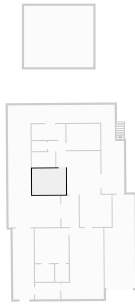

▼ **Bedroom**
1st Floor

WIDTH: 3.85 m • LENGTH: 2.98 m
AREA: 11.47 m² • PERIMETER: 13.66 m

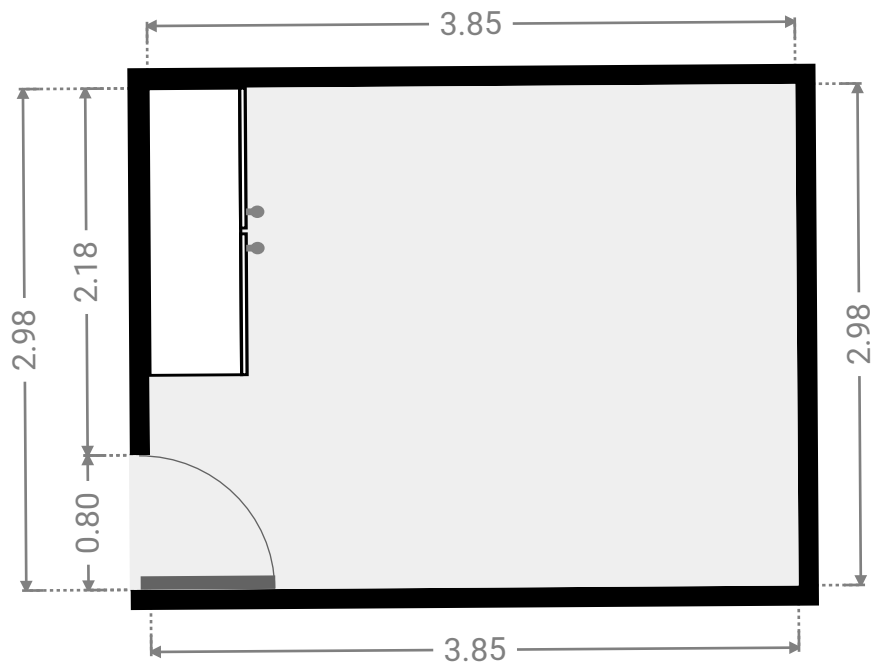
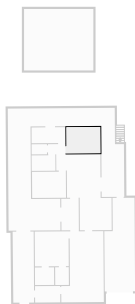

▼ **Bathroom**
1st Floor

WIDTH: 2.70 m • LENGTH: 1.76 m
AREA: 4.75 m² • PERIMETER: 8.92 m

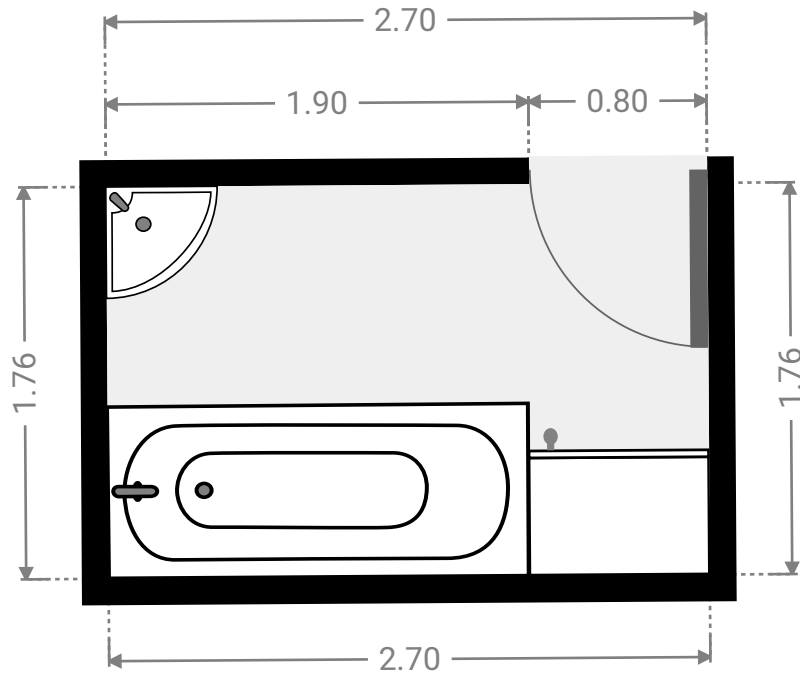
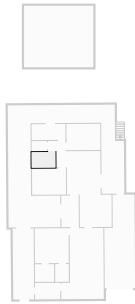

▼ **Toilet**
1st Floor

WIDTH: 1.74 m • LENGTH: 1.15 m
AREA: 2.00 m² • PERIMETER: 5.78 m

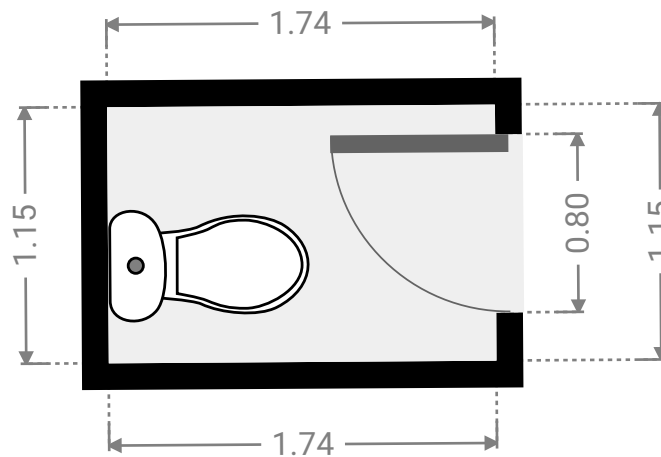

▼ Study
1st Floor

WIDTH: 3.85 m • LENGTH: 1.82 m
AREA: 6.93 m² • PERIMETER: 11.30 m

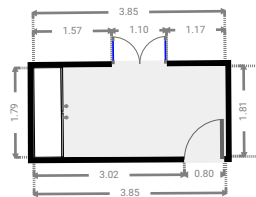
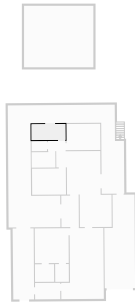

▼ Other
1st Floor

WIDTH: 13.20 m • LENGTH: 13.91 m
AREA: 86.05 m² • PERIMETER: 77.04 m

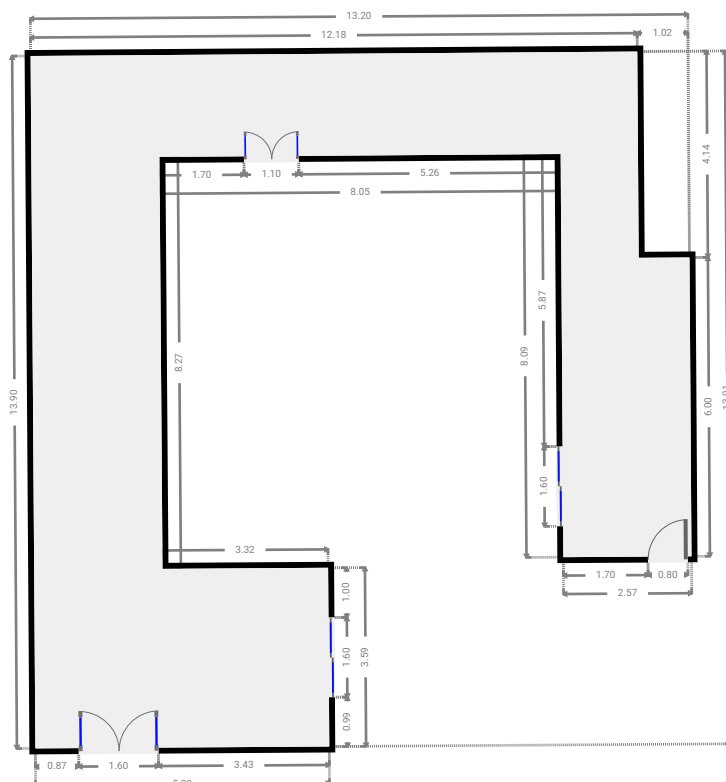
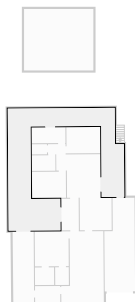

▼ Garage
1st Floor

WIDTH: 3.46 m • LENGTH: 10.65 m
AREA: 33.16 m² • PERIMETER: 28.20 m

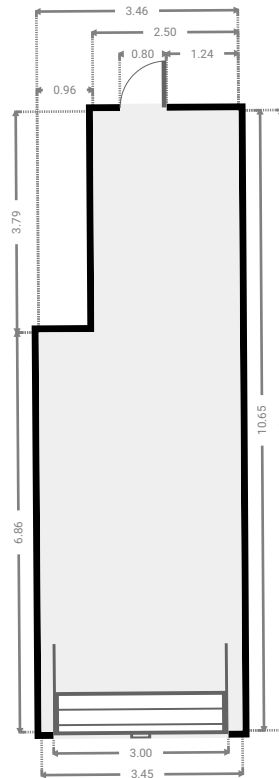

▼ Other
1st Floor

WIDTH: 2.40 m • LENGTH: 8.09 m
AREA: 19.23 m² • PERIMETER: 20.93 m

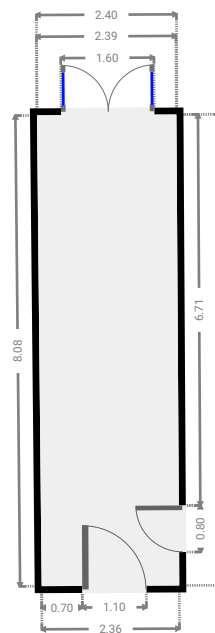

▼ Other
1st Floor

WIDTH: 2.87 m • LENGTH: 1.87 m
AREA: 5.33 m² • PERIMETER: 9.45 m

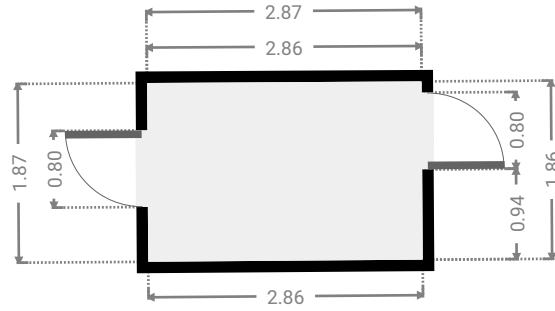

▼ Entertainment Area
1st Floor

WIDTH: 7.89 m • LENGTH: 7.00 m
AREA: 55.23 m² • PERIMETER: 29.78 m

