

# 28 Geoff Wilson Drive

Created on  
2021-09-21

Floors  
1

▼ Ground Floor



▼ **Hall**  
Ground Floor

WIDTH: 1.28 m • LENGTH: 4.28 m  
AREA: 5.48 m<sup>2</sup> • PERIMETER: 11.12 m

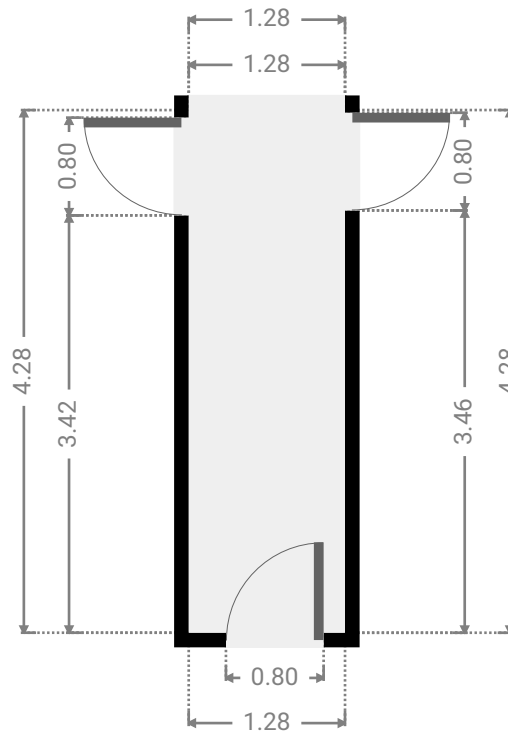
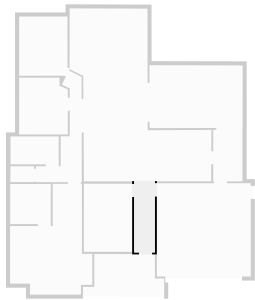

▼ **Bedroom**  
Ground Floor

WIDTH: 2.98 m • LENGTH: 4.20 m  
AREA: 12.52 m<sup>2</sup> • PERIMETER: 14.36 m

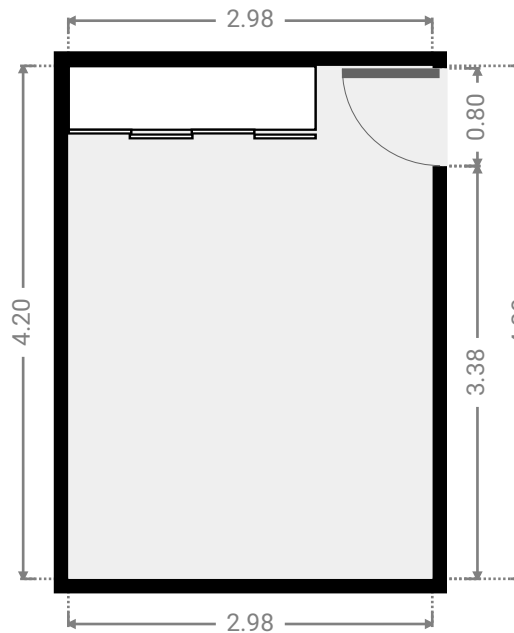
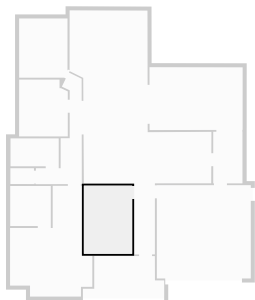

▼ **Garage**  
Ground Floor

WIDTH: 5.79 m • LENGTH: 5.75 m  
AREA: 33.29 m<sup>2</sup> • PERIMETER: 23.08 m

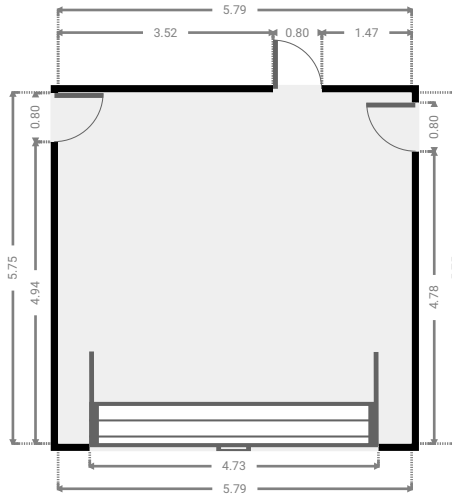
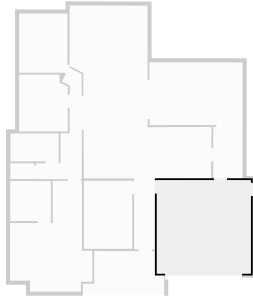

▼ **Kitchen**  
Ground Floor

WIDTH: 8.73 m • LENGTH: 10.70 m  
AREA: 57.86 m<sup>2</sup> • PERIMETER: 38.42 m

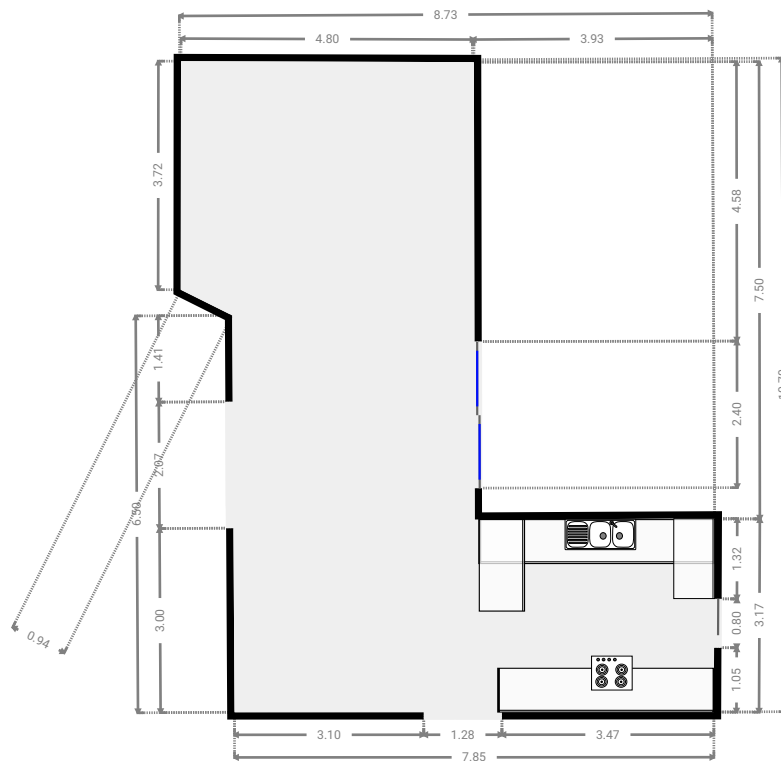
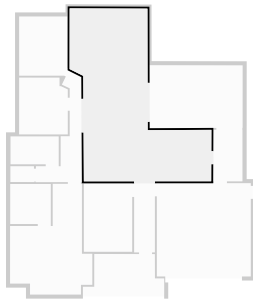

▼ **Laundry Room**  
Ground Floor

WIDTH: 1.80 m • LENGTH: 3.18 m  
AREA: 5.72 m<sup>2</sup> • PERIMETER: 9.96 m

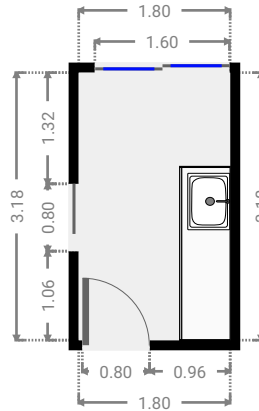
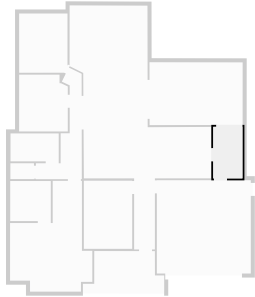

▼ **Hall**  
Ground Floor

WIDTH: 2.83 m • LENGTH: 6.88 m  
AREA: 8.30 m<sup>2</sup> • PERIMETER: 19.58 m

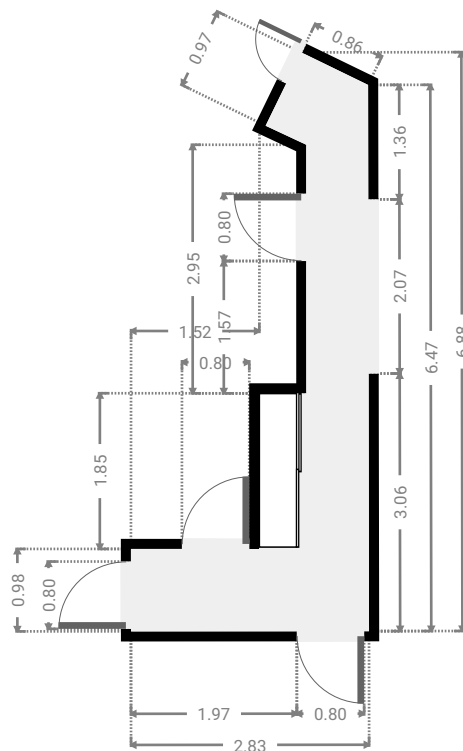
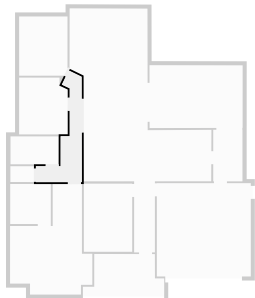

▼ **Master Bedroom**  
Ground Floor

WIDTH: 5.07 m • LENGTH: 6.83 m  
AREA: 23.76 m<sup>2</sup> • PERIMETER: 23.79 m

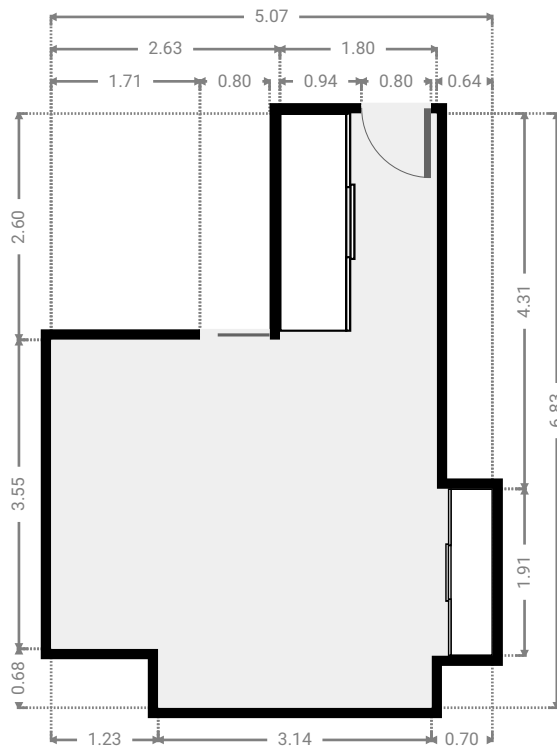
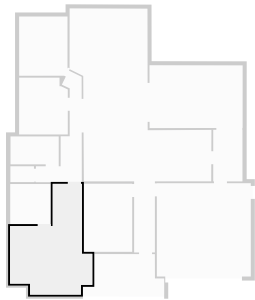

▼ **Bathroom**  
Ground Floor

WIDTH: 2.50 m • LENGTH: 2.47 m  
AREA: 6.17 m<sup>2</sup> • PERIMETER: 9.94 m

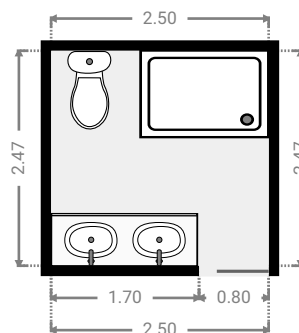
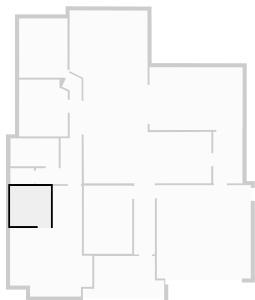

▼ **Toilet**  
Ground Floor

WIDTH: 1.45 m • LENGTH: 0.98 m  
AREA: 1.42 m<sup>2</sup> • PERIMETER: 4.86 m

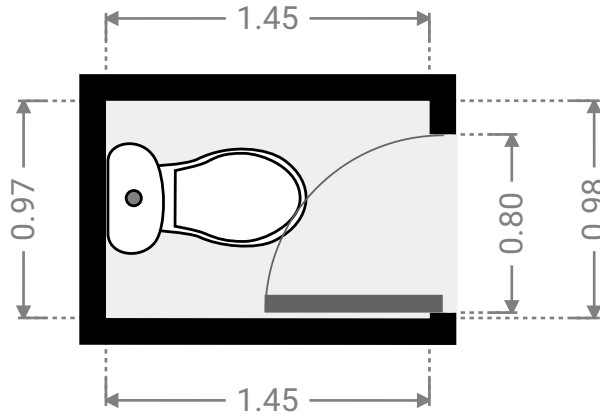
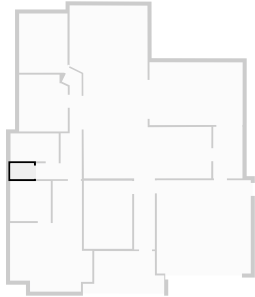

▼ **Bathroom**  
Ground Floor

WIDTH: 2.97 m • LENGTH: 1.72 m  
AREA: 5.11 m<sup>2</sup> • PERIMETER: 9.38 m

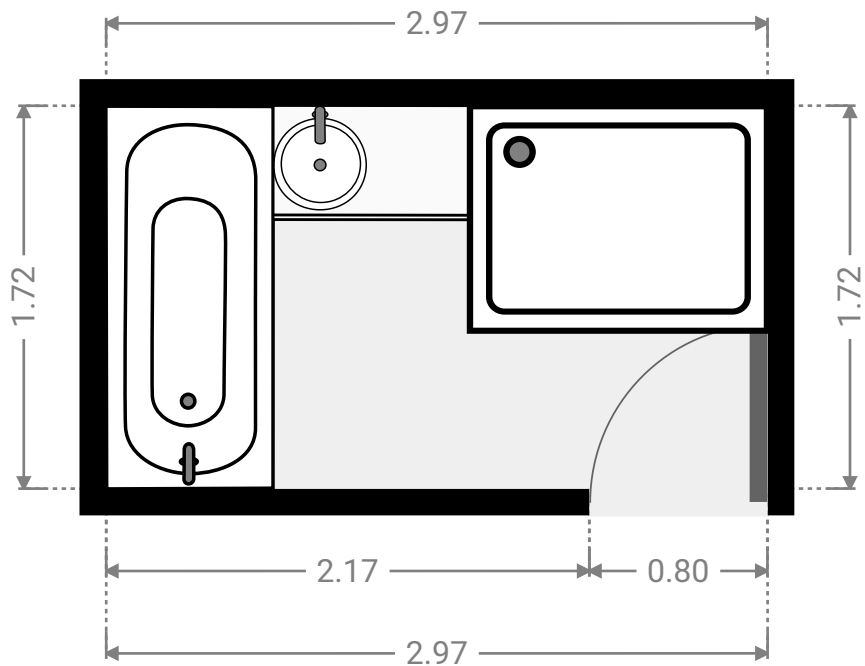
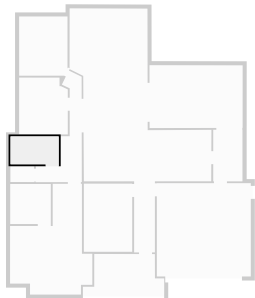

▼ **Bedroom**  
Ground Floor

WIDTH: 3.00 m • LENGTH: 3.50 m  
AREA: 10.18 m<sup>2</sup> • PERIMETER: 12.84 m

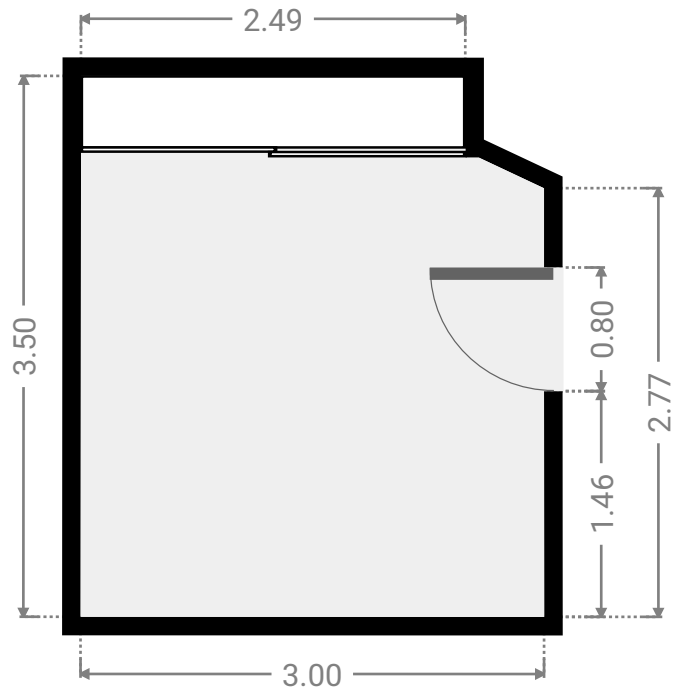
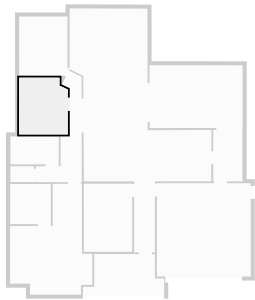

▼ **Bedroom**  
Ground Floor

WIDTH: 2.98 m • LENGTH: 3.65 m  
AREA: 10.83 m<sup>2</sup> • PERIMETER: 13.10 m

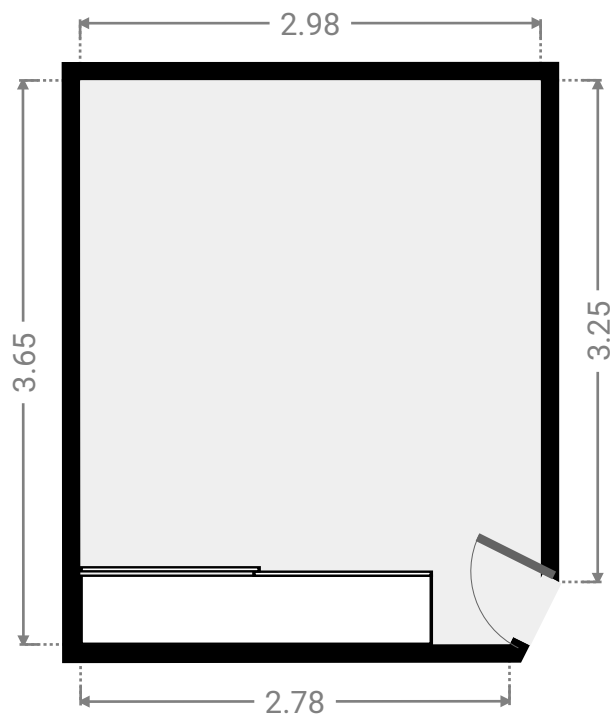
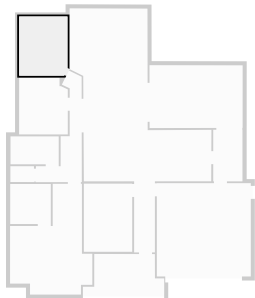



▼ Other  
Ground Floor

WIDTH: 5.74 m • LENGTH: 3.88 m  
AREA: 22.18 m<sup>2</sup> • PERIMETER: 19.20 m

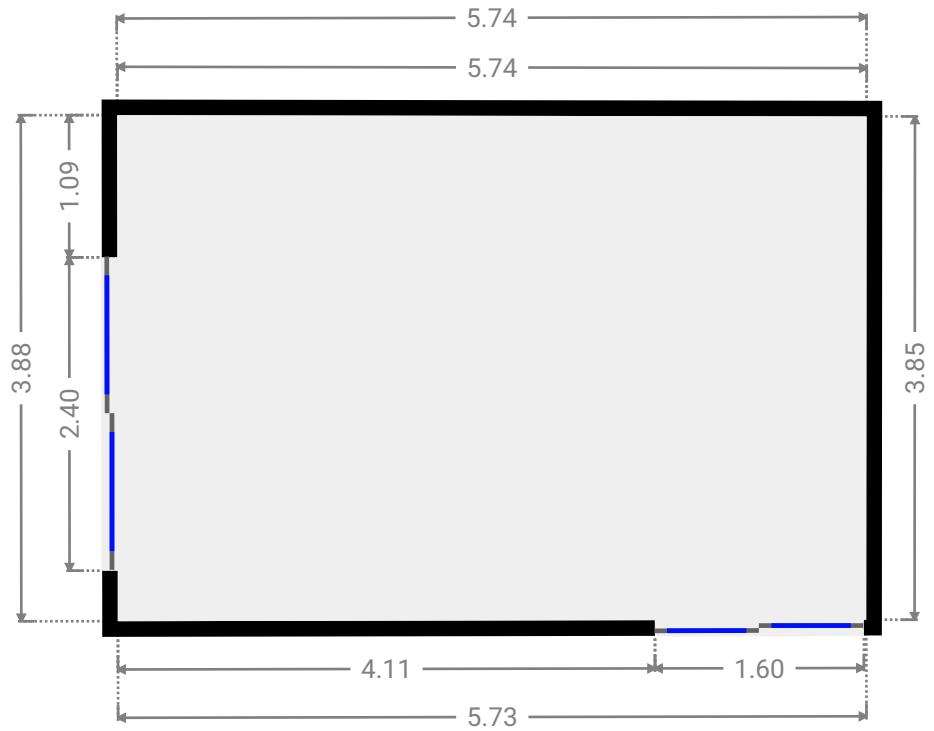
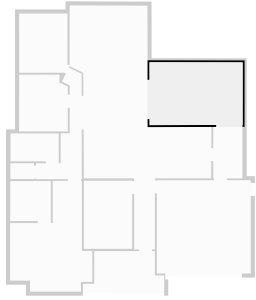

▼ Other  
Ground Floor

WIDTH: 5.01 m • LENGTH: 2.51 m  
AREA: 10.24 m<sup>2</sup> • PERIMETER: 15.01 m

