

28 Elgin Street

SUBMITTED BY
Ray White Rockhampton Casey
stockers@cqoz.com

CREATED ON
2022-05-30

Floors
2

▼ Ground Floor

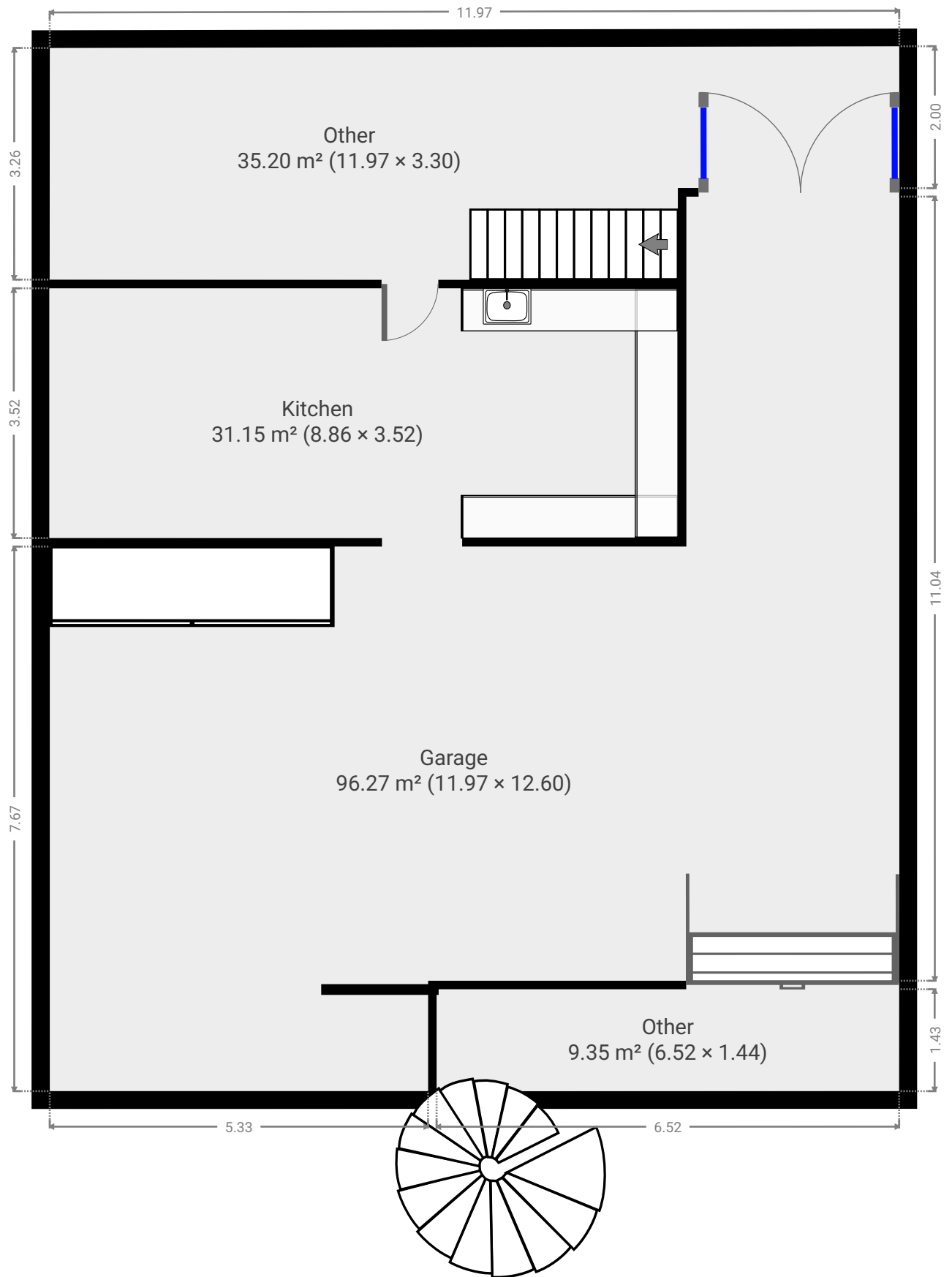

▼ **Garage**
Ground Floor

WIDTH: 11.97 m • LENGTH: 12.60 m
AREA: 96.27 m² • PERIMETER: 49.14 m

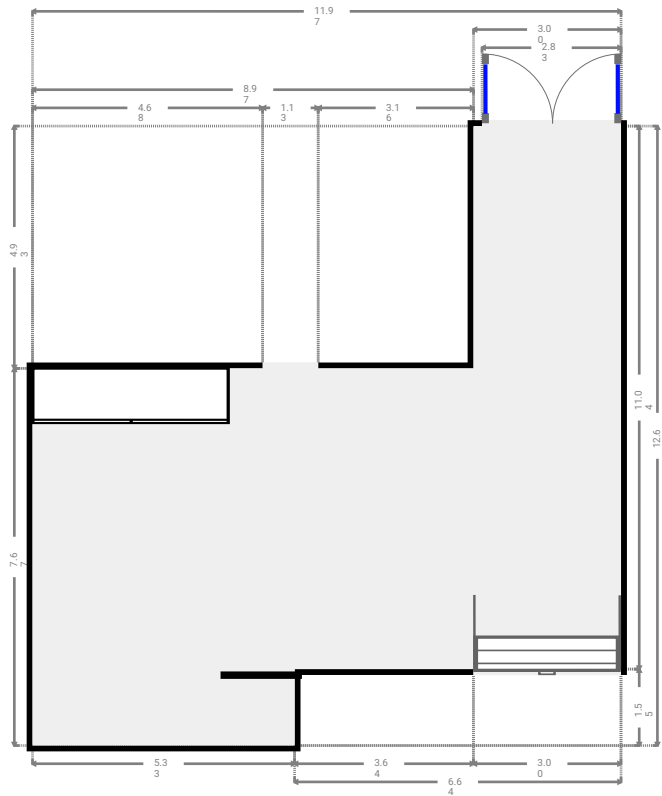
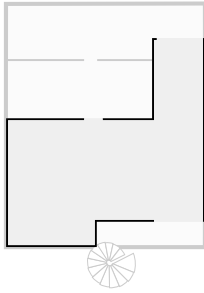

▼ **Kitchen**
Ground Floor

WIDTH: 8.86 m • LENGTH: 3.52 m
AREA: 31.15 m² • PERIMETER: 24.75 m

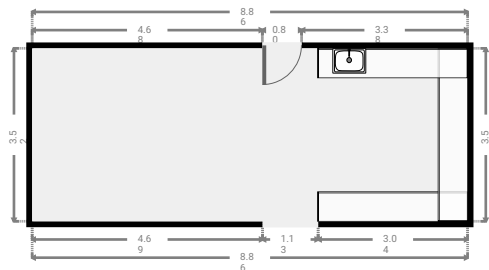
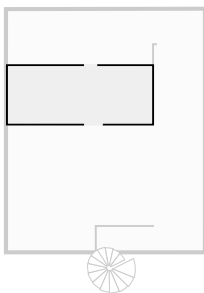

▼ Other
Ground Floor

WIDTH: 11.97 m • LENGTH: 3.30 m
AREA: 35.20 m² • PERIMETER: 30.50 m

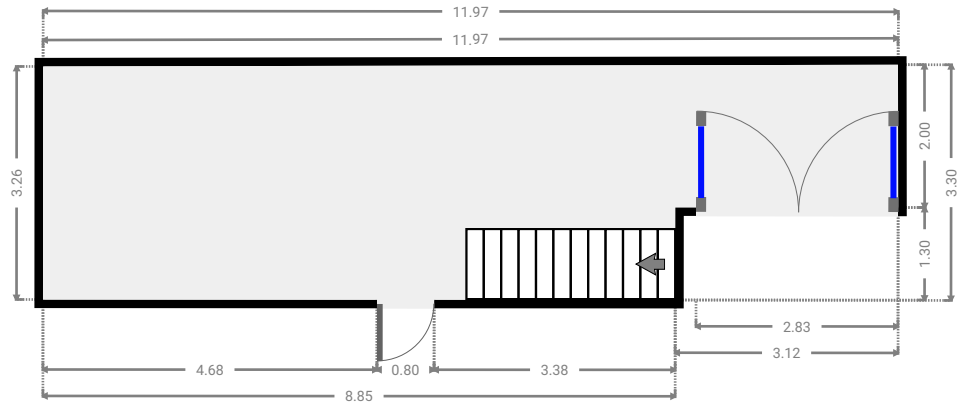
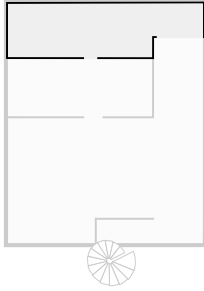

▼ Other
Ground Floor

WIDTH: 6.52 m • LENGTH: 1.44 m
AREA: 9.35 m² • PERIMETER: 15.91 m

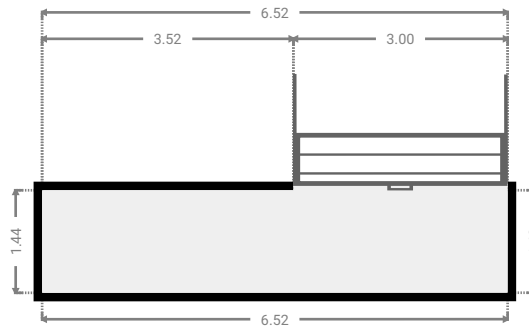
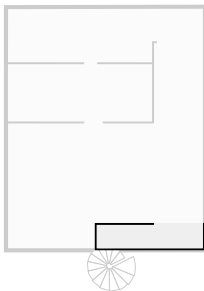

▼ 1st Floor

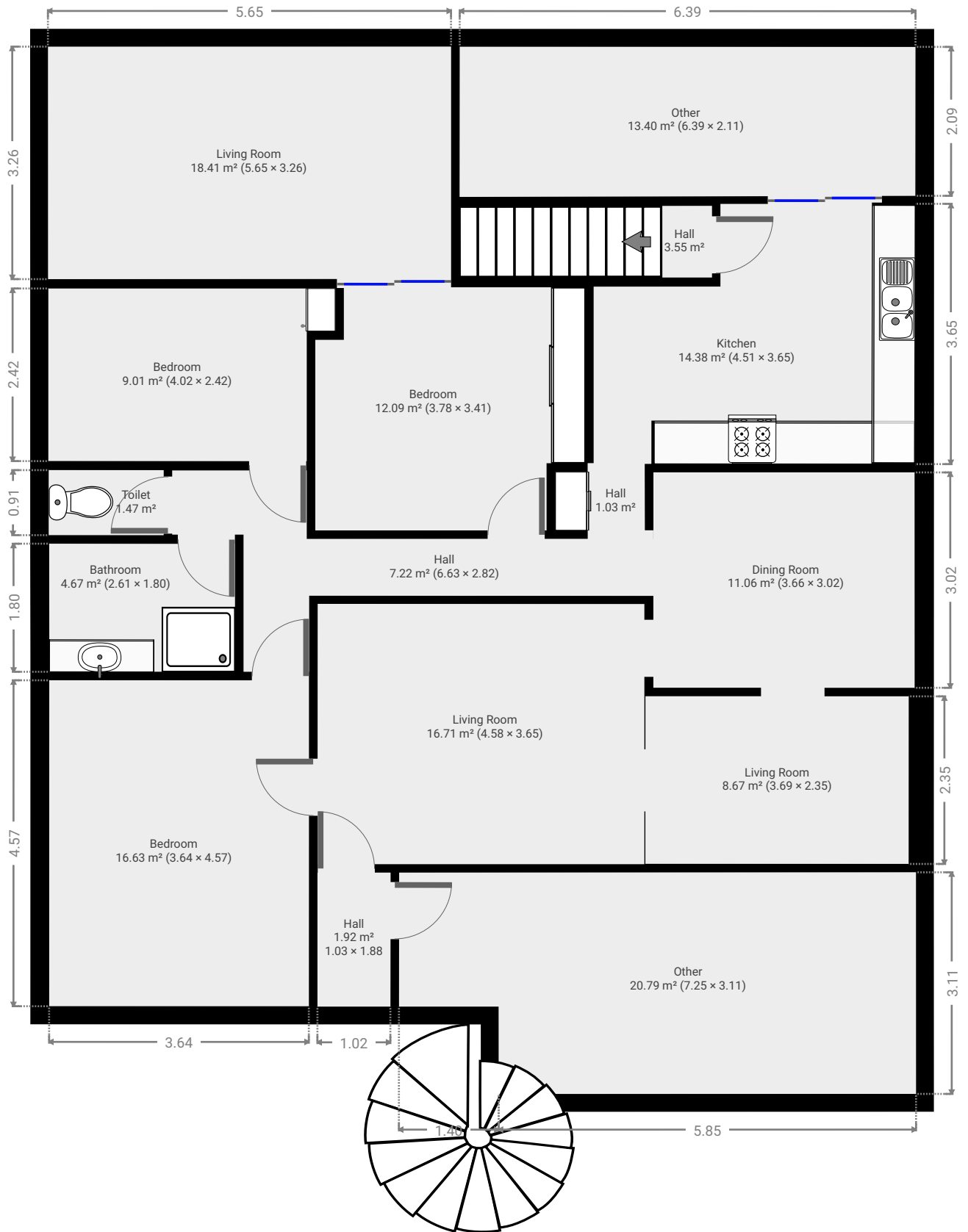

▼ **Bathroom**
1st Floor

WIDTH: 2.61 m • LENGTH: 1.80 m
AREA: 4.67 m² • PERIMETER: 8.80 m

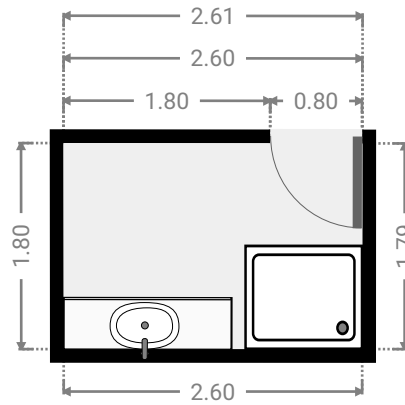
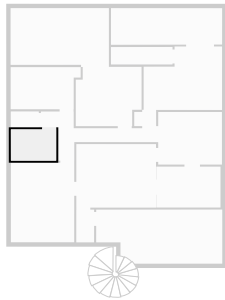

▼ **Bedroom**
1st Floor

WIDTH: 3.64 m • LENGTH: 4.57 m
AREA: 16.63 m² • PERIMETER: 16.42 m

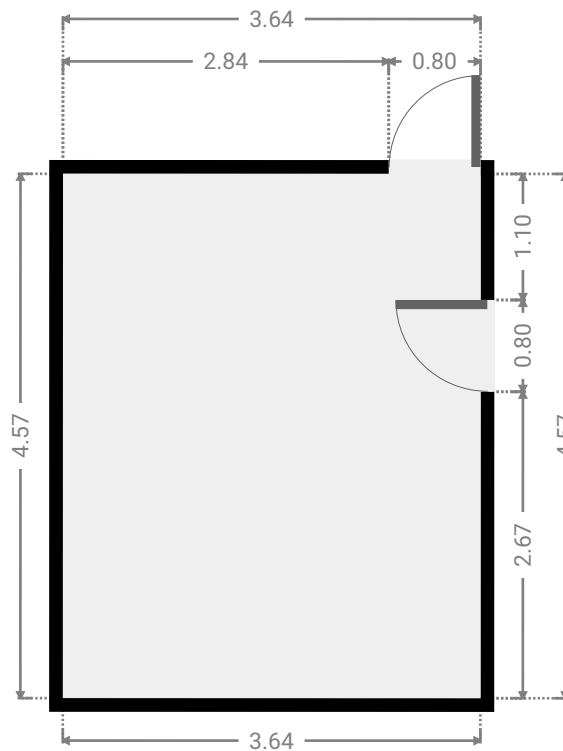
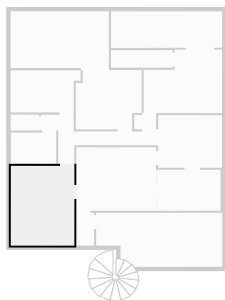

▼ **Bedroom**
1st Floor

WIDTH: 4.02 m • LENGTH: 2.42 m
AREA: 9.01 m² • PERIMETER: 12.89 m

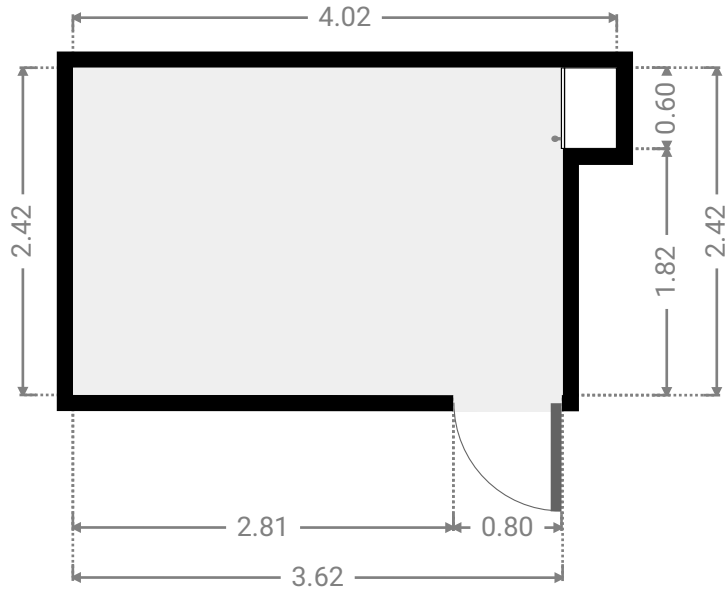
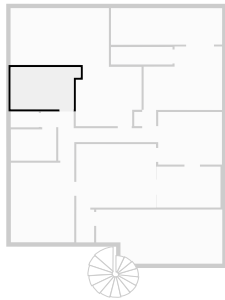

▼ **Bedroom**
1st Floor

WIDTH: 3.78 m • LENGTH: 3.41 m
AREA: 12.09 m² • PERIMETER: 14.38 m

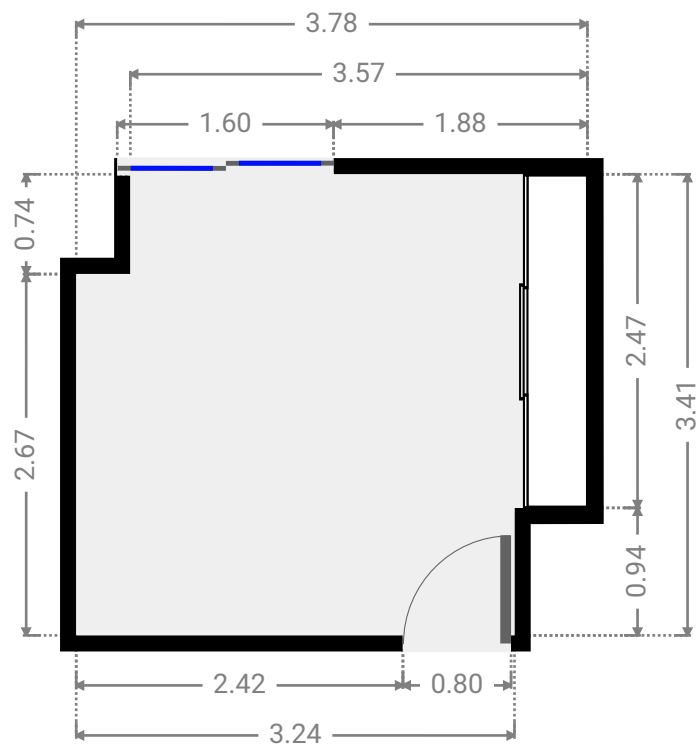
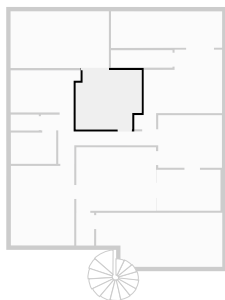

▼ Dining Room
1st Floor

WIDTH: 3.66 m • LENGTH: 3.02 m
AREA: 11.06 m² • PERIMETER: 13.36 m

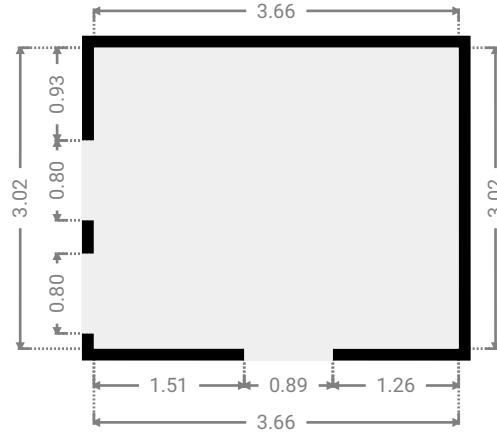
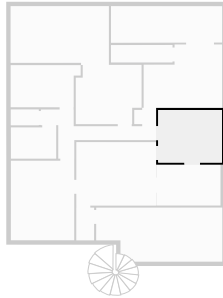

▼ Hall
1st Floor

WIDTH: 6.63 m • LENGTH: 2.82 m
AREA: 7.22 m² • PERIMETER: 18.90 m

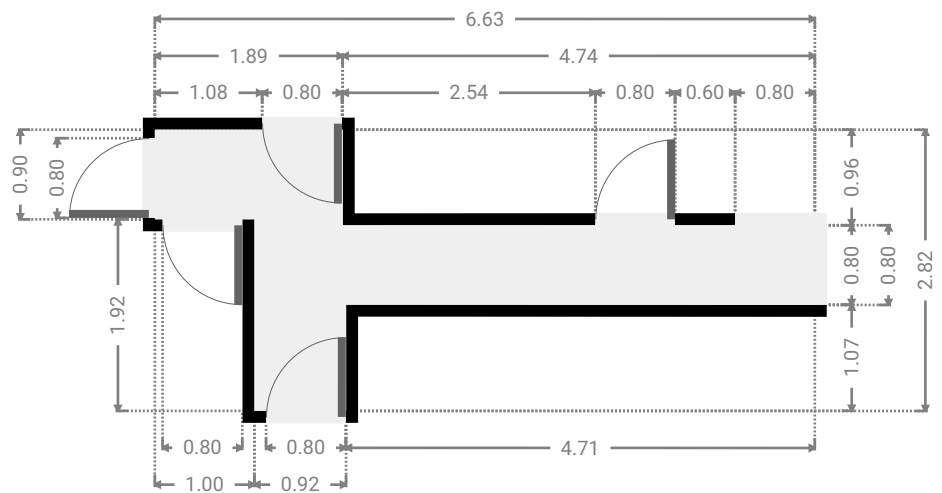
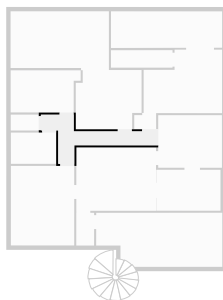

▼ **Hall**
1st Floor

WIDTH: 1.26 m • LENGTH: 0.82 m
AREA: 1.03 m² • PERIMETER: 4.15 m

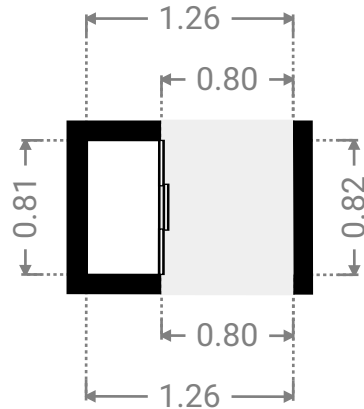
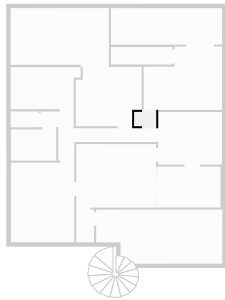

▼ **Hall**
1st Floor

WIDTH: 3.54 m • LENGTH: 1.00 m
AREA: 3.55 m² • PERIMETER: 9.08 m

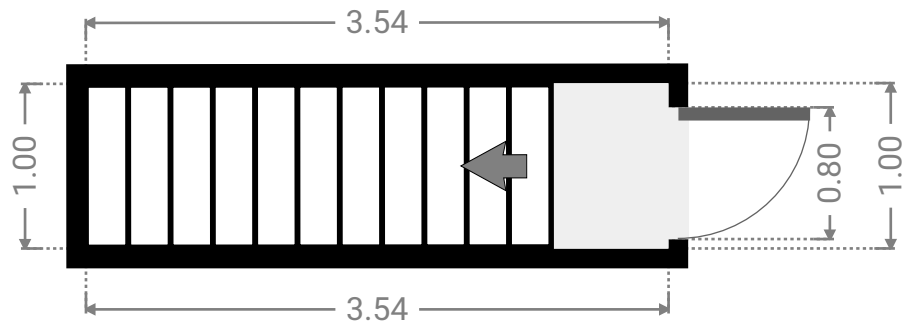
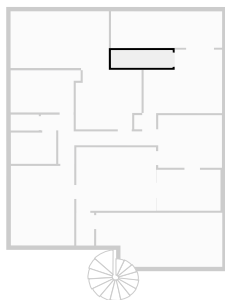

▼ **Hall**
1st Floor

WIDTH: 1.03 m • LENGTH: 1.88 m
AREA: 1.92 m² • PERIMETER: 5.81 m

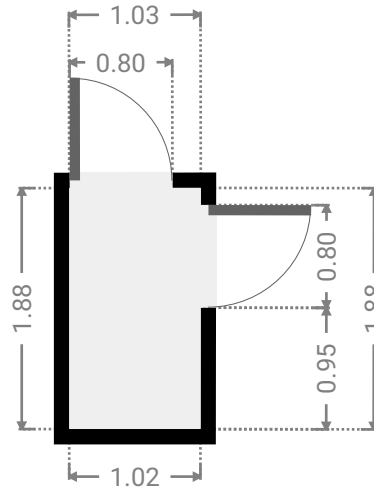
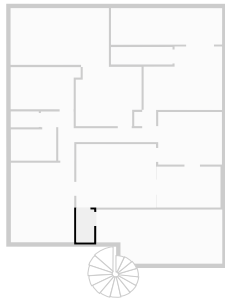

▼ **Kitchen**
1st Floor

WIDTH: 4.51 m • LENGTH: 3.65 m
AREA: 14.38 m² • PERIMETER: 16.31 m

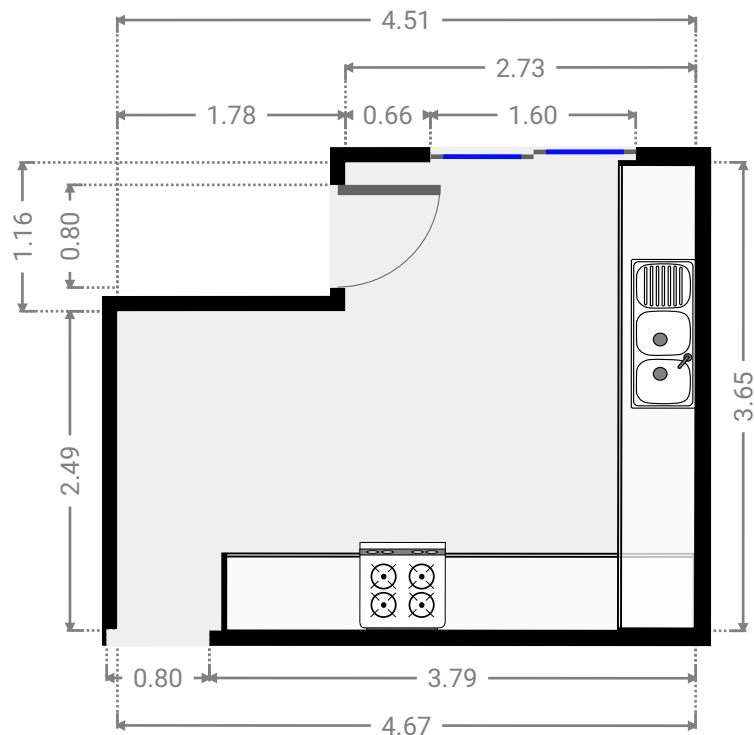
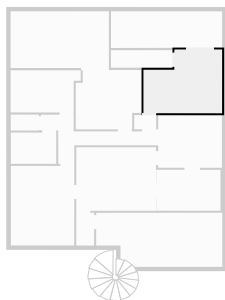

▼ Living Room
1st Floor

WIDTH: 4.58 m • LENGTH: 3.65 m
AREA: 16.71 m² • PERIMETER: 16.46 m

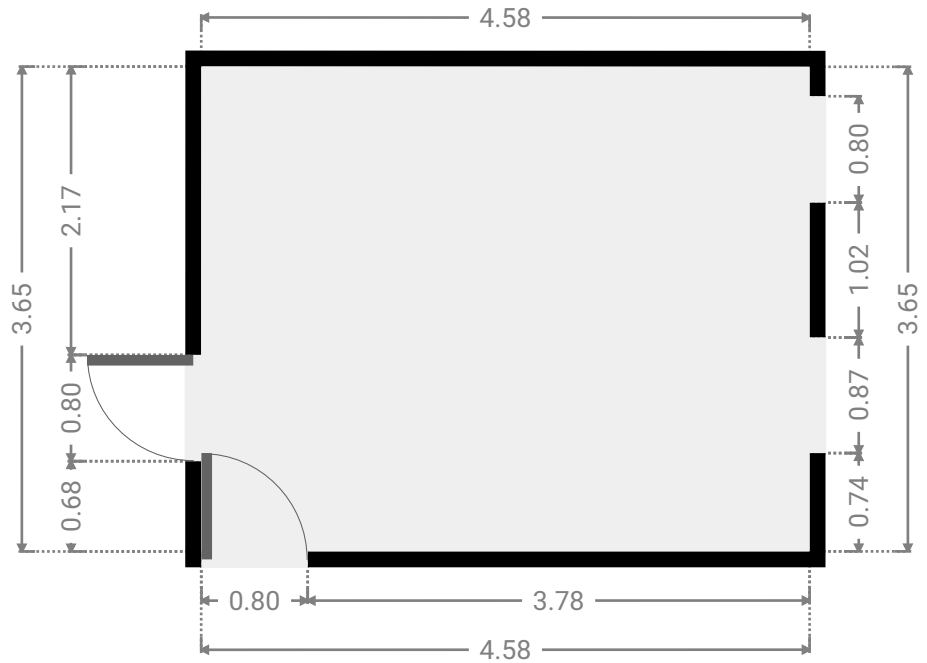
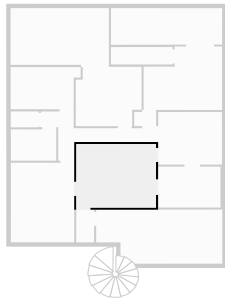

▼ Living Room
1st Floor

WIDTH: 3.69 m • LENGTH: 2.35 m
AREA: 8.67 m² • PERIMETER: 12.08 m

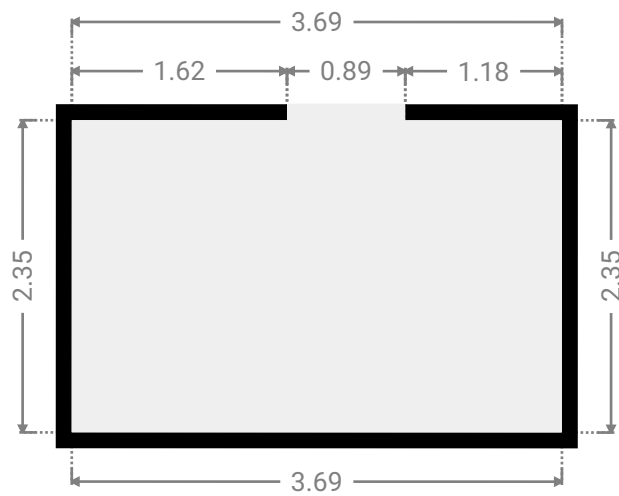
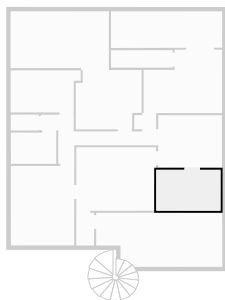

▼ **Living Room**
1st Floor

WIDTH: 5.65 m • LENGTH: 3.26 m
AREA: 18.41 m² • PERIMETER: 17.82 m

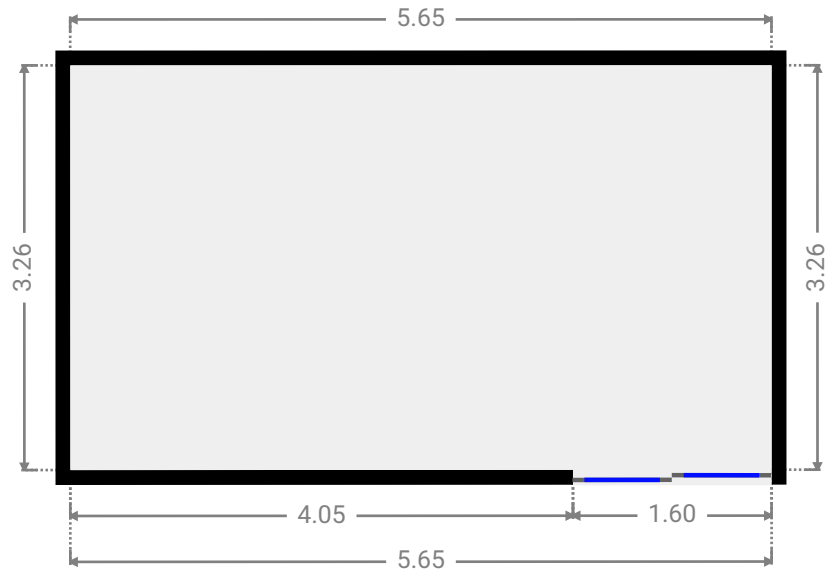
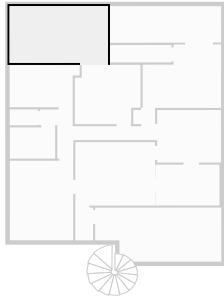

▼ **Other**
1st Floor

WIDTH: 6.39 m • LENGTH: 2.11 m
AREA: 13.40 m² • PERIMETER: 16.97 m

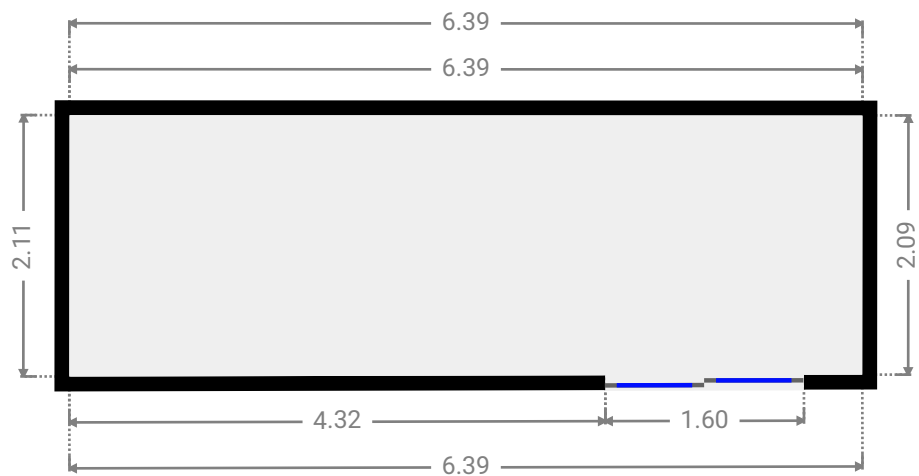
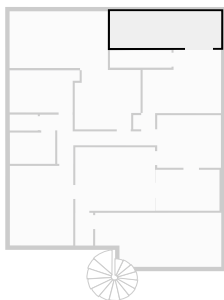

▼ **Other**
1st Floor

WIDTH: 7.25 m • LENGTH: 3.11 m
AREA: 20.79 m² • PERIMETER: 20.70 m

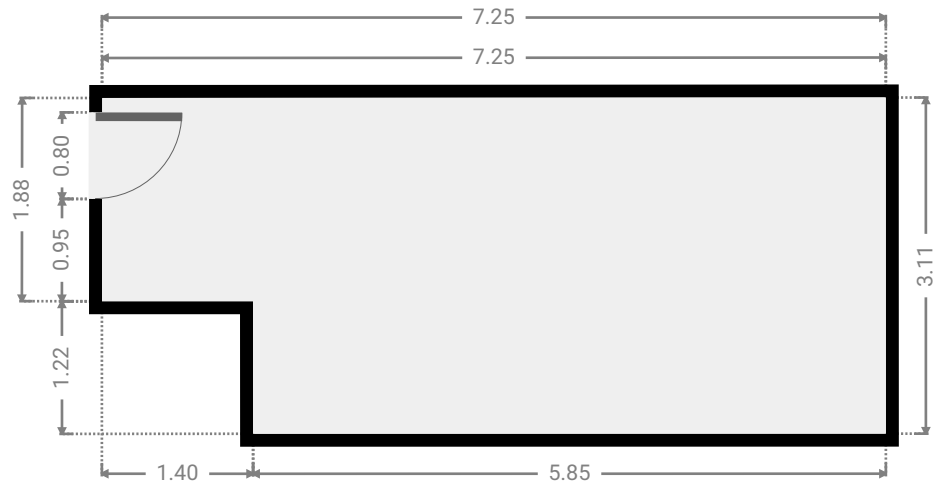
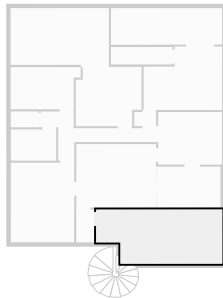

▼ **Toilet**
1st Floor

WIDTH: 1.61 m • LENGTH: 0.91 m
AREA: 1.47 m² • PERIMETER: 5.05 m

